

# LAGUNA

# DP:EO

## Owner's Manual



SKU: MDP20-1

LAGUNA

Thank you for investing in a DP20 Drill Press by Laguna Tools. This drill press is one of a family of unique machines proudly offered by Laguna Tools. Every Laguna machine is engineered for years of dependable service. Please feel free to contact Laguna Tools if you have a question or suggestion. We appreciate working with you and your choice of a Laguna Tools machine for your shop.

Regards,  
Torben Helshoj  
President & Founder Laguna Tools

This manual applies to the DP20 Drill Press. Enter the model number and serial number below for quick reference when ordering accessories, supplies or parts.

Model: \_\_\_\_\_

Date of purchase: \_\_\_\_\_

Serial: \_\_\_\_\_

Place of purchase: \_\_\_\_\_

## **Laguna Tools**

744 Refuge Way, Suite 200  
Grand Prairie TX 75050

800-234-1976

[www.lagunatools.com](http://www.lagunatools.com)

Revision: R01 V05 07/31/2025

### **LATEST MANUAL:**

Below is a QR code and URL which will direct you to the Laguna Tools manual reference page, where the latest version of the manual is located on the Laguna Tools website. The online manual may have updates and information added after the printed copy was released. Scan the code with your smartphone or copy the URL link to be directed to the latest manual page to reference your specific machine and model.

<https://lagunatools.com/resources/product-manuals/#classic>



# CONTENTS

Warranty	04
Safety	05
*Electrical	09
Video & Information	10
Specifications	11
Main Components & Controls	15
Inventory	16
Unpacking & Assembly	17
Electrical Connections	25
Control Panel	25
Programming	28
RPM Selection/Drill Speed	33
Depth Stop	36
Laser Light	36
Using the Drill Press	39
Maintenance	40
Trouble Shooting	41
Wiring Diagram	42
Exploded Views	43
Parts List	45
Accessories	53

# WARRANTY & REGISTRATION

## Thank You!

Welcome to the Laguna Tools® group of discriminating industrial machinery owners. We understand that you have a choice of where to purchase your machines and appreciate the confidence you have in the Laguna Tools® brand.

Through hands-on experience, Laguna Tools® is constantly working hard to make innovative, precision products. Products that inspire you to create works of art are a joy to operate and encourage your best work.

Laguna Tools®  
Imagination, Innovation, and Invention at Work

## Warranty & Registration

Every product sold is warranted to be free of manufacturer's defective workmanship, parts, and materials. For any questions about this produce, the intended use or what it was designed for, customer service, or replacement parts, please contact our customer service department:

Laguna Tools® Customer Service  
744 Refuge Way, Grand Prairie, Texas 75050, USA  
1-800-234-1976  
customerservice@lagunatools.com  
www.lagunatools.com/why/customer-service/ 8AM.  
To 5PM PSF. Monday through Friday

For warranty claims or to report damage upon receiving-please reach out to our warranty department:

Laguna Tools® Warranty Service  
744 Refuge Way, Grand Prairie, Texas 75050, USA  
1-800-234-1976  
customerservice@lagunatools.com  
www.lagunatools.com/policies/warranty  
8AM to 5PM PST, Monday through Friday

## Registration

To prevent voiding this warranty, all products sold must be registered within thirty (30) days of receiving the product. Registering the product will enable the original purchaser to receive notifications about important product changes, receive customer service, and be able to file a warranty claim against defective workmanship, parts, or materials.



## Who is Covered

The applicable warranty covers only the initial purchaser of the product from the date of receiving the product. To file such claims, the original purchaser must present the original receipt as proof of purchase.

## What is Covered

The warranty covers any defects in the workmanship of all parts and materials that make up the machine unless otherwise specified. Any part determined by Laguna Tools® to have a defect will be repaired or replaced (and shipped), without charge. The defective item/part must be returned to Laguna Tools® with the complaint and proof of purchase in the original packaging that it was received in. In the event the item/part is determined to be not covered by this warranty, the customer will be responsible for the cost to replace the item/part and all related shipping charges.

## Warranty Limitations

This limited warranty does not apply to natural disasters, acts of terrorism, normal wear and tear, product failure due to lack of maintenance or cleaning, damage caused by accident, neglect, or lack-of inadequate dust collection. The warranty may be voided against proof of misuse/abuse, damage caused where repair or alterations have been made or attempted by others, using the product for purposes other than those described as intended use (unless with consent by Laguna Tools®), modification to the product, or use with an accessory that was not designed for the product. It is the responsibility of the user to understand basic woodworking machinery settings and procedures and to properly maintain the equipment in accordance with the standards provided in this manual.

## Length of Warranty

All new machines and optional accessories sold through an authorized dealer carry a two-year warranty effective from the date of receiving the product. Machines sold for either commercial or industrial use have a one-year warranty. Wearable parts like throat plates, bandsaw guides, etc., have a ninety-day warranty.

**Table A-1 Warranty Lengths**

2 Year – New Machines Sold Through an Authorized Dealer
2 Year – Accessories Sold as Machine Options (excluding blades)
1 Year – Machines Sold for Commercial or Industrial Use
1 Year – Blades and Accessories outside or Machine Options
90 Days – Wearable Parts

Aside from being free of defects upon receiving, consumable parts, like cutters and abrasives, are not covered by this warranty unless otherwise stated by Laguna Tools®. These parts are designed to be used at the expense of the operator and are available for replacement or inventory purchase. The determination of a consumable part will be made on a case-by-case basis by Laguna Tools®.

## Shipping Damage

Laguna Tools® is not responsible for damage or loss caused by a freight company or other circumstances not in the direct control of Laguna Tools®. All shipping-related claims for loss or damage to goods must be made to Laguna Tools® within twenty-four hours of delivery.

## How to Receive Support

To file a warranty claim, please contact the warranty department at 1-800-234-1976. To receive customer service or technical support, please contact the customer service department at 1-800-332-4094. Parts, under warranty, are shipped at the expense of Laguna Tools® either by common carrier, FedEx ground services, or similar method. Technical support to install replacement parts is primarily provided by phone, fax, email, or the Laguna Tools® Customer Service Support Website.



# Receiving your machine

It is probable that your machine will be delivered by a third party. Before you unpack your new machine, you will need to first inspect the packing, invoice and shipping documents supplied by the driver.

Ensure that there is no visible damage to the packaging or the machine. You need to do this prior to the driver leaving. All damage must be noted on the delivery documents and signed by you and the delivery driver. You must then report the damage to the seller within 24 hours.

## SAFETY GUIDELINES - DEFINITIONS

This manual contains information that is important for you to know and understand. This information relates to protecting YOUR SAFETY and PREVENTING EQUIPMENT PROBLEMS. To help you recognize this information, we use the symbols below. Please read the manual and pay attention to these sections.



Indicates an imminently hazardous situation which, if not avoided, **will** result in death or serious injury.



Indicates a potentially hazardous situation which, if not avoided, **could** result in death or serious injury.



Indicates a potentially hazardous situation which, if not avoided, **may** result in minor or moderate injury.

**CAUTION**

(Used without the safety alert symbol) indicates a potentially hazardous situation which, if not avoided, **may** result in property damage.

### Proposition 65 Warning

Some dust created by power sanding, sawing, grinding, drilling, and other construction activities contain chemicals known to cause cancer, birth defects or other reproductive harm. Some examples of these chemicals are:

- **Lead** from lead-based paint.
- **Crystalline silica** from bricks, cement, and other masonry products.
- **Arsenic** and **chromium** from chemically treated lumber.

Your risk of exposure varies, depending on how often you do this type of work. To reduce your exposure to these chemicals, work in a well-ventilated area and work with approved safety equipment, such as face or dust masks that are specifically designed to filter out microscopic particles.

# Laguna

English	French
<p><b>WARNING:</b> For your own safety, read instruction manual before operating bandsaw</p> <ol style="list-style-type: none"> <li>1. Wear eye protection.</li> <li>2. Do not remove jammed cut off pieces until blade has stopped.</li> <li>3. Maintain proper adjustment of blade tension, blade guides and thrust bearings.</li> <li>4. Adjust upper guide to just clear workpiece.</li> <li>5. Hold workpiece firmly against table.</li> <li>6. ALWAYS USE A PUSH STICK. Never allow your hands/ fingers to come close to the bandsaw blade.</li> </ol>	<p><b>AVERTISSEMENT:</b> Pour votre securite, lisez le manuel d'instruction attentivement avant d'utiliser la scie à ruban.</p> <ol style="list-style-type: none"> <li>1. Portez des lunettes de protection .</li> <li>2. Ne tentez pas d'enlever une piece coincée avant l'arrêt complet de la lame.</li> <li>3. Assurez-vous que les guides et la tension sur la lame soient toujours correctement ajustés.</li> <li>4. Ajustez la hauteur du guide supérieur de façon à passer juste au-dessus de la piece .</li> <li>5. Tenez la piece fermement sur la table.</li> <li>6. UTILISEZ TOUJOURS UN POUSSOIR - N'approchez jamais vos doigts, ou vos main, de la lame .</li> </ol>
<b>Safety Rules</b>	<b>Regles de securite</b>
<ol style="list-style-type: none"> <li>1. KEEP GUARDS IN PLACE and in working order.</li> <li>2. REMOVE ADJUSTING KEYS AND WRENCHES. Form a habit of checking to see that the keys and adjusting wrenches are removed from tool before turning it on.</li> <li>3. KEEP WORK AREA CLEAN. Cluttered areas and benches invite accidents.</li> <li>4. DON'T USE IN DANGEROUS ENVIRONMENT. Do not use power tools in damp or wet locations or expose them to rain. Keep work area well lighted.</li> <li>5. KEEP CHILDREN AWAY. All visitors should be kept safe distance from work area.</li> <li>6. MAKE WORKSHOP KID PROOF with padlocks, master switches or by removing starter keys.</li> <li>7. . DON'T FORCE TOOL. It will do the job better and safer at the rate for which it was designed.</li> <li>8. USE RIGHT TOOL. Do not force tool or attachment to do a job for which it was not designed.</li> <li>9. USE PROPER EXTENSION CORD. Make sure your extension cord is in good condition. When using an extension cord, be sure to use one heavy enough to carry the current your product will draw. An undersized cord will cause a drop in line voltage, resulting in loss of power and overheating. Table A shows the correct size to use depending on cord length and nameplate ampere rating. If in doubt, use the next heavier gage. The smaller the gage number, the heavier the cord.</li> <li>10. WEAR PROPER APPAREL. Do not wear loose clothing, gloves, neckties, rings, bracelets, or other jewelry that may get caught in moving parts. Nonslip footwear is recommended. Wear protective hair covering to contain long hair.</li> <li>11. ALWAYS USE SAFETY GLASSES. Also use face or dust mask if cutting operation is dusty. Everyday eyeglasses only have impact-resistant lenses; they are NOT safety glasses.</li> </ol>	<ol style="list-style-type: none"> <li>1. CONSERVEZ TOUS LES DISPOSITIFS DE PROTECTION EN PLACE et en bon état de fonctionnement .</li> <li>2. ENLEVEZ LES CLES ET OUTILS. Prenez l'habitude de vérifier si les clés et autres outils ne sont pas trop près de la machine avant de la démarrer.</li> <li>3. CONSERVEZ LA SURFACE DE TRAVAIL PROPRE ET LIBRE D'ENTRAVES. Les endroits encombrés augmentent le risque d'accident.</li> <li>4. NE PAS UTILISER DANS LES ENVIRONNEMENTS DANGEREUX. N'utilisez pas d'outils électriques dans les endroits humides, détrempés, ou sous la pluie. Conservez l'espace de travail bien éclairé.</li> <li>5. TENEZ LES ENFANTS À L'ÉCART. Tous les visiteurs doivent être tenus à une distance sécuritaire de l'aire de travail.</li> <li>6. RENDEZ L'ATELIER À L'ÉPREUVE DES ENFANTS avec des verrous, des interrupteurs principaux ou en enlevant les clés de démarrage sur les outils.</li> <li>7. NE FORCEZ PAS L'OUTIL. L'outil effectuera un meilleur travail et de façon sécuritaire s'il est utilisé au rythme pour lequel il a été conçu.</li> <li>8. UTILISEZ L'OUTIL APPROPRIÉ. Ne forcez pas un outil ou un accessoire pour effectuer un travail pour lequel il n'a pas été conçu.</li> <li>9. UTILISEZ UNE RALLONGE ÉLECTRIQUE APPROPRIÉE. Assurez-vous que votre rallonge électrique est en bon état et que le calibre du filage soit adéquat pour transporter le courant que la machine a besoin. Une rallonge de trop faible calibre induira une perte d'intensité du voltage, ce qui provoquera une surchauffe et une perte de puissance . Le tableau A indique le bon calibre à utiliser en fonction de la longueur de la rallonge et de la demande en intensité du moteur. En cas de doute, utilisez la rallonge de calibre plus fort . Plus le numéro est petit , plus la rallonge est de fort calibre .</li> </ol>

12. SECURE WORK. Use clamps or a vise to hold work when practical. It is safer than using your hand, and it frees both hands to operate tool.
13. DON'T OVERREAC H. always Keep proper footing and balance.
14. MAINTAIN TOOLS WITH CARE. Keep tools sharp and clean for best and safest performance. Follow instructions for lubricating and changing accessories.
15. DISCONNECT TOOLS before servicing, when changing accessories such as blades, bits, and cutters.
16. REDUCE THE RISK OF UNINTENTIONAL STARTING. Make sure switch is in off position before plugging in.
17. USE RECOMMENDED ACCESSORIES. Consult the owner's manual for recommended accessories. The use of improper accessories may cause risk of injury to persons.
18. NEVER STAND ON TOOL Serious injury could occur if the tool is tipped or if the cutting tool is unintentionally contacted.
19. CHECK DAMAGED PARTS. Before further use of the tool, a guard or other part that is damaged should be carefully checked to determine that it will operate properly and perform its intended function - check for alignment of moving parts, binding of moving parts, breakage of parts, mounting and any other conditions that may affect its operation. A guard or other part that is damaged should be properly repaired or replaced.
20. DIRECTION OF FEED. Feed work into a blade or cutter against the direction of rotation of the blade or cutter only.
21. NEVER LEAVE TOOL RUNNING UNATTENDED TURN POWER OFF. Do not leave tool until it comes to a complete stop.

10. PORTEZ DES VETEMENTS APPROPRIES. Ne portez pas de vetements amples, des gants, des colliers, des bracelets, ou tout autre bijou ou accessoire qui pourrait etre entra1ne par des pieces mobiles . Des souliers a semelle antiderapante sont egalement recommandes . Attachez les cheveux longs et portez un bonnet pour contenir la chevelure trop abondante.
11. PORTEZ DES LUNETTES DE PROTECTION. Portez egalement un masque contre la poussiere si le travail execute degage de la poussiere. Veuillez prendre note que les lunettes de prescription ordinaire ne resistant pas aux impacts et qu'elles ne sont pas homologuees a titre de lunettes de securite.
12. IMMOBILISEZ VOTRE TRAVAIL. Utilisez des serres ou un etau pour immobiliser votre travail lorsque c'est possible. C'est plus securitaire que d'utiliser votre main, et <;a permet de liberer vos deux mains pour operer l'outil confortablement.
13. NE VOUS ETIREZ PAS AU-DESSUS DE LA M ACHINE. Demeurez solidement en equilibre sur vos pieds en tout temps.
- 14 . ENTRETENEZ LES OUTILS AVEC SOIN. Gardez les outils de coupe tranchants et propres pour en tirer les meilleures performances. Suivez les instructions du fabricant pour la lubrification et l'entretien des accessoires .
- 15 . DEBRANCHEZ LES OUTILS avant d'en effectuer l'entretien ou lors du changement d'accessoires tels que lames ou couteaux.
16. REDUISEZ LES RISQUES DE DEMARRAGE NON INTENTIONNEL. Assurez-vous que l'interrupteur est en position fermee avant le branchement d'un outil.
17. UTILISEZ LES ACCESSOIRES RECOMMANDES. Consultez le manuel d'instruction pour conna1tre les accessoires recommandes. L'utilisation d'accessoires inappropriés pose des risques de blessures aux utilisateurs .
- 18 . NE VOUS TENEZ JAMAIS DEBOUT SUR UNE M ACHINE. Des blessures graves pourraient survenir si la machine bascule ou si les outils coupants sont touches accidentellement .
19. VERIFIEZ LES PIECES ENDOM M AGEES. Avant de poursuivre l'utilisation d'un outil, tout dispositif de protection ou toute piece endommagee devra etre inspecte pour determiner si elle peut fonctionner correctement et selon l'utilisation qui en est prevue . Verifiez l'alignement des pieces mobiles a savoir s'il ya blocage, un bris, ou toute autre condition qui nuirait a son utilisation . Une piece ou un protecteur endommage doit etre repare ou

**! WARNING**



- This machine starts and stops automatically.
- For Your Own Safety, Read And Follow Instruction Manual Before Operating Drill Press.
- Always Wear Proper Eye Protection When Operating This Machine.
- Do Not Expose to Rain or Use In Damp Locations.
- Do Not Operate This Machine While Under The Influence Of Drugs, Alcohol, or Medication.
- Do Not Operate While Wearing Loose Clothing, Necktie, Jewelry, Gloves, Or Unrestrained Long Hair That May Get Caught In Moving Parts Of The Machine.
- Always Clamp Workpiece To Prevent Material Rotation.
- Select Proper Tooling And Speeds For Material Being Drilled.
- Always Remove Chuck Key Before Starting Drill Press.
- Disconnect Machine From Power Source Before Performing Any Maintenance Or When Changing Tooling.
- Flying Chips, Sparks, Coolant, And Other Particles Can Cause Serious Injury. Use Shields Or Other Safeguards Appropriate To Tooling And Materials Used.
- Lock Out Power Before Servicing.
- This Label Does Not Cover All Safety Hazards.
- Scan QR Code For The Most Current Manual, Instructions, and Tutorial Videos.



remplace.

20. **SENS D'ALIMENTATION.** Alimentez la pièce vers la lame ou le couteau dans le sens contraire de sa rotation seulement.
21. **NE LAISSEZ JAMAIS UN OUTIL FONCTIONNER DANS SURVEILLANCE - ETEIGNEZ L'OUTIL.** Ne laissez pas l'outil sans surveillance jusqu'à ce qu'il s'arrête complètement.

**! AVERTISSEMENT**



- Cette machine démarre et s'arrête automatiquement.
- Pour votre sécurité, lisez et suivez le manuel d'instructions avant d'utiliser la perceuse à colonne.
- Portez toujours une protection oculaire appropriée lorsque vous utilisez cette machine.
- Ne pas exposer à la pluie ou utiliser dans des endroits humides.
- Ne pas utiliser cette machine sous l'influence de drogues, d'alcool ou de médicaments.
- Ne pas utiliser en portant des vêtements amples, une cravate, des bijoux, des gants ou les cheveux non attachés, car ils pourraient être happés par les parties mobiles de la machine.
- Fixez toujours la pièce à usiner pour éviter toute rotation accidentelle.
- Sélectionnez les outils et les vitesses appropriés pour le matériau à percer.
- Retirez toujours la clé du mandrin avant de démarrer la perceuse.
- Débranchez la machine de la source d'alimentation avant toute maintenance ou changement d'outil.
- Les copeaux volants, les étincelles, le liquide de refroidissement et d'autres particules peuvent causer des blessures graves. Utilisez des écrans de protection ou d'autres dispositifs de sécurité appropriés aux outils et aux matériaux utilisés.
- Coupez l'alimentation avant toute intervention de maintenance.
- Cette étiquette ne couvre pas tous les dangers possibles.
- Veuillez suivre ce lien pour consulter les manuels et instructions les plus récents

Table A						
Ampere Rating		Volts	Total length of cord in feet			
		120	25	50	100	150
		240	50	100	200	300
More Than	Not More Than		Minimum gage for cord			
0	6		18	16	16	14
6	10		18	16	14	12
10	12		16	16	14	12
12	16		14	12	Not Recommended	

## GROUNDING INSTRUCTIONS



### 1. All grounded, cord-connected tools:

In the event of a malfunction or breakdown, grounding provides a path of least resistance for electric current to reduce the risk of electric shock. This tool is equipped with an electric cord having an equipment-grounding conductor and a grounding plug. The plug must be plugged into a matching outlet that is properly installed and grounded in accordance with all local codes and ordinances.

Do not modify the plug provided – if it will not fit the outlet, have the proper outlet installed by a qualified electrician.

Improper connection of the equipment-grounding conductor can result in a risk of electric shock. The conductor with insulation having an outer surface that is green with or without yellow stripes is the equipment-grounding conductor. If repair or replacement of the electric cord or plug is necessary, do not connect the equipment-grounding conductor to a live terminal.

Check with qualified electrician or service personnel if the grounding instructions are not completely understood, or if in doubt as to whether the tool is properly grounded.

Use only 3-wire extension cords that have 3-prong grounding plugs and 3 pole receptacles that accept the tool's plug.

Repair or replace damaged or worn cord immediately.

### 2. Grounded, cord-connected tools intended for use on a supply circuit having a nominal rating less than 150 volts:

This tool is intended for use on a circuit that has an outlet that looks like the one illustrated in Sketch A in Fig. 1. The tool has a grounding plug that looks like the plug illustrated in Sketch A in Fig. 1. A temporary adapter, which looks like the adapter illustrated in Sketch B and C, may be used to connect this plug to a 2-pole receptacle as shown in Sketch B if a properly grounded outlet is not available. The temporary adapter should be used only until a properly grounded outlet can be installed by a qualified electrician. **This adapter is not permitted in Canada.** The green-colored rigid ear, lug, and the like, extending from the adapter, must be connected to a permanent ground, such as a properly grounded outlet box.

3. Grounded, cord-connected tools intended for use on a supply circuit having a nominal rating of 150–250 volts, inclusive:

This tool is intended for use on a circuit that has an outlet that looks like the one illustrated in Sketch D. The tool has a grounding plug that looks like the plug illustrated in Sketch D. Make sure the tool is connected to an outlet having the same configuration as the plug. No adapter is available or should be used with this tool. If the tool must be reconnected for use on a different type of electric circuit, the reconnection should be made by qualified service personnel; and after reconnection, the tool should comply with all local codes and ordinances.

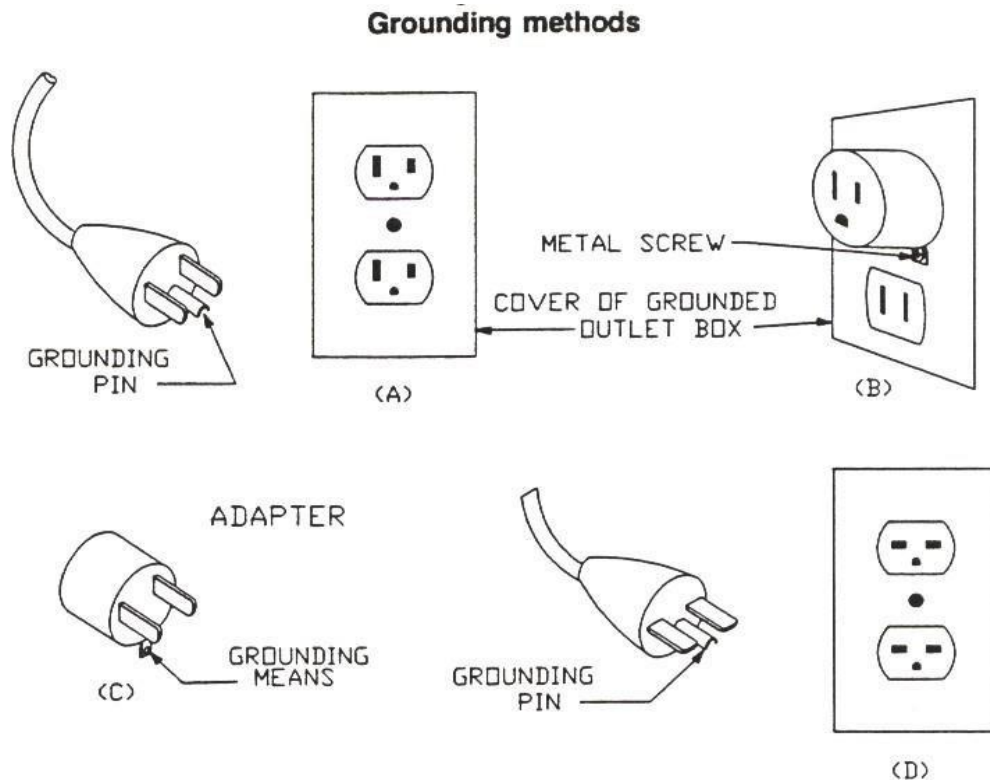

## DP20 Video & Information

Below is a link and QR code to a DP20 video showing features and operation information. It is a great way to familiarize the unique features and capabilities of this new era of drill press offerings from Laguna Tools. Copy the URL or scan the QR code.

[www.lagunatools.com/classic/drill-presses/dp20/](http://www.lagunatools.com/classic/drill-presses/dp20/)



## Specifications

	<b>DP20</b>
<b>Motor voltage</b>	110-120 Volt
<b>Breaker</b>	15 amp. min.
<b>Horsepower</b>	1.5 HP
<b>Power cord</b>	72" (1830mm)
<b>Table, cast iron</b>	15" x 22" (380mm x 560mm)
<b>Table tilt</b>	+/- 90 degrees
<b>Table swivel</b>	360 degrees
<b>Laser light</b>	Included
<b>Working light</b>	LED, 5W
<b>Swing</b>	20" (510mm)
<b>Spindle taper</b>	MT2
<b>Spindle travel</b>	6" (152.4mm)
<b>Chuck</b>	5/64" – 5/8" (2-16mm)
<b>Quill diameter</b>	2.17" (55mm)
<b>Quill flange/collar diameter</b>	2.6" (66mm)
<b>Spindle to column, max.</b>	10" (255mm)
<b>Spindle to table, max.</b>	29-5/16" (745mm)
<b>Spindle to base</b>	49.5" (1257mm)
<b>Spindle speed range</b>	60-3600 RPM (electronic & variable)
<b>Column diameter</b>	3.15" (80mm)
<b>Machine Dimensions (L x W x H) (vertical, base footprint)</b>	23-7/8" x 17" x 72.5" (607mm x 432mm x 1842mm)
<b>Weight, gross</b>	326 lbs. (148 kg)
<b>Weight, net</b>	304 lbs. (138 kg)
<b>Package size (W x D x H) (horizontal)</b>	72.5" x 28.5" x 20" (1840mm x 725mm x 406mm)
<b>Industrial work light</b>	One LED included within headstock & others optional



Figure 1: DP20

### Operating Environment:

1. **Rated Voltage:** AC 110~120V
2. **Rated Operating Current:** 10A
3. **Operating Temperature Range:** -10~50°C
4. **Intended Use Environment:** Indoor, household use with good ventilation.

**Warning: Use only in specified conditions. Improper use may cause damage or injury**

# Drill Press Introduction

This drill press is designed to give you years of safe service. Read this owner's manual in its entirety before assembly or use.

The drill press does not have many parts. The major parts are discussed in this manual. If you are not familiar with the drill press, take the time to read this section and become familiar with the machine.

**NOTE:** The handle for controlling the arbor/chuck depth can be attached to either the right or left side of the drill press.

## Control Panel/Touch Screen:

The control panel's touch screen controls both basic functions as Start/Stop, RPM, rotation direction, LED light, laser, etc. It also allows programming of functions, such as tapping holes. Read the section detailing the Control Panel for more information about use and programming.

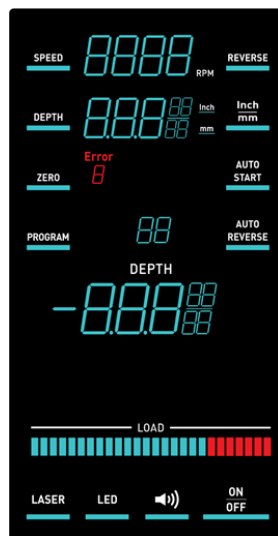

Figure 2: Control Panel

## Power Switches:

- **Main Power**

To start the machine, lift the paddle of the start/stop switch, at the back of the headstock. To shut off power to the machine press down on the paddle. To prevent unwanted use, remove the yellow lock key from the center of the switch, when it is OFF. Do not lose the yellow lock key as the machine will not operate without this key.



Figure 3: Main Power Switch (back of headstock)

- **E-STOP**

An emergency STOP button (red) is located on the front of the headstock. Depress the red knob to stop the machine. Twist the red button to reset and turn power back on. Only reset this button after the emergency has been corrected.



Figure 4: Emergency-STOP (Twist to reset)

- **Start/Stop.**

The “ON/OFF” switch for starting the chuck or a program is located at the bottom, right of the Control Panel.

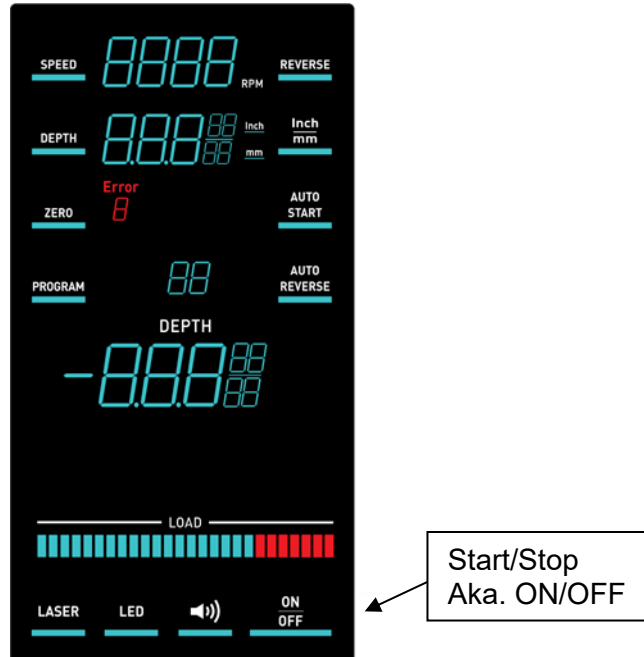

Figure 5: Start/Stop button

**Identification/Serial label:**

There is a plate at the back of the machine (below the main power switch) listing the manufacturing data, including the serial number and model.

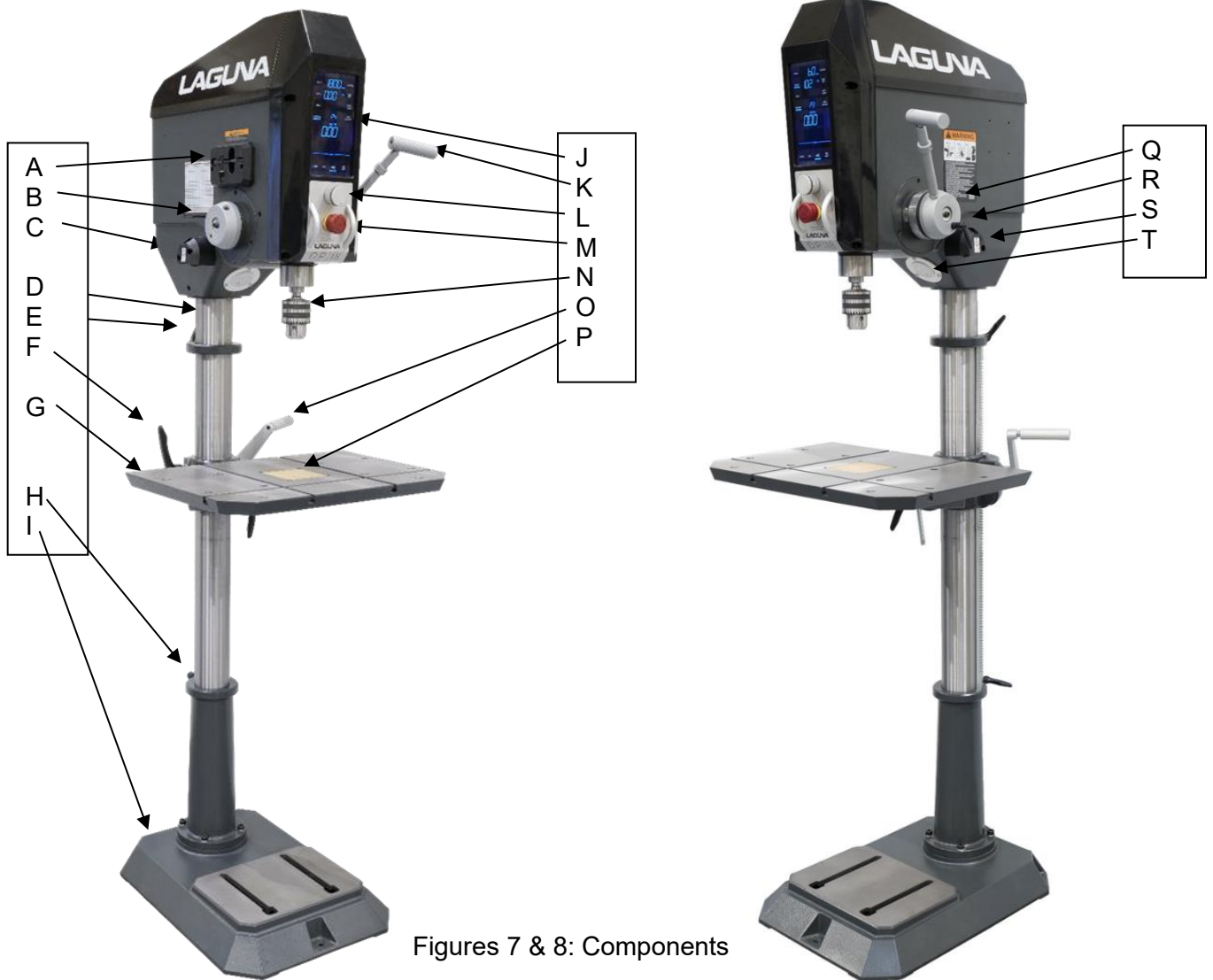

Figure 6: Identification Label

**Motor (*Not Shown*):**

The drill press is supplied with a 1-1/2 hp, 110V motor. The motor drives the quill and Chuck through a pulley system. It is contained within the headstock.

# Main Components & Controls of the Drill Press



Figures 7 & 8: Components

- A. Key, chuck
- B. Quill Control, Left
- C. Laser, Left 1/2
- D. Column
- E. Column Lock, Top 1/3
- F. Table Column Lock, 2/3
- G. Table
- H. Colum Lock, Bottom 3/3
- I. Base

- J. Touch Screen Controls, PLC
- K. Handle, Arbor Depth Control, Right
- L. RPM & Programming Control
- M. E-Stop
- N. Chuck
- O. Table Elevation Handle
- P. Table Insert
- Q. Depth Scale
- R. Depth Stop Lock
- S. Laser, Right 1/2
- T. Light

## Where to locate your Drill Press

Before you remove your drill press from the packaging, select the area where you will use your machine. There are no hard-and-fast rules for its location, but below are a few guidelines.

1. There should be an area at the front, back and sides of the machine suitable for the length of material that you will be processing.
2. Adequate lighting. The better the lighting, the more accurately and safely you will be able to work.
3. Solid floor. You should select a solid, flat floor, preferably concrete or something similar.
4. Close to power source and, ideally, dust or debris collection.

## Inventory - What you will receive with your Drill Press

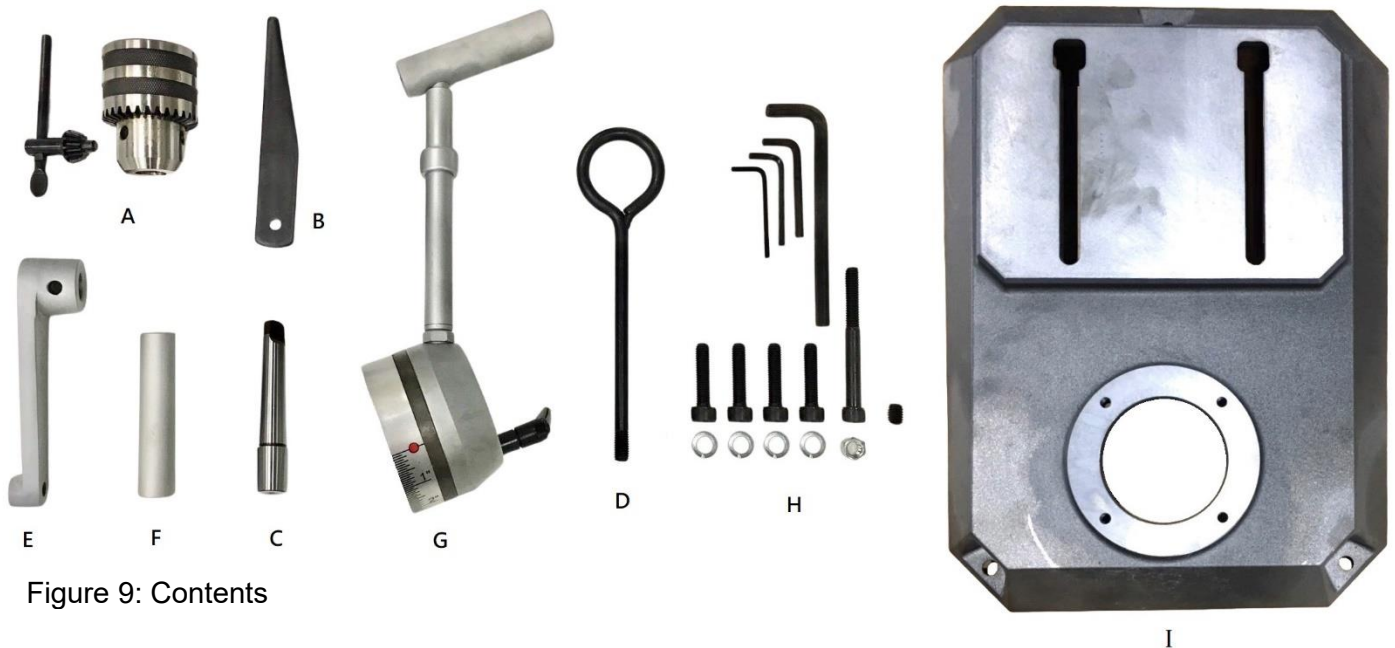

Figure 9: Contents

- A. Key & Chuck
- B. Drift Key (arbor release tool)
- C. Arbor
- D. Eye Bolt for lifting
- E. Table Height Adjustment Crank
- F. Table Height Adjustment Handle
- G. Feed Handle and Depth Stop/Lock
- H. Hardware
- I. Base

## Unpacking & Assembly

Unpacking requires; tin snips, knife, and wrench.  
Assembly requires; Hex Wrenches

**Note:** The machine is heavy, and if you have any doubt about the described procedure, seek professional assistance. Do not attempt any procedure that you feel is unsafe or that you do not have the physical capability of achieving.

Using the tin snips, cut the banding that is securing the machine to the pallet (if fitted).  
**WARNING: EXTREME CAUTION MUST BE USED BECAUSE THE BANDING WILL SPRING AND COULD CAUSE INJURY.**

Your drill press is shipped in custom packaging consisting of a heavy-duty cardboard box and Styrofoam internal packaging.

Hint: Place the crate on a low, stable stand if lifting the machine with the help of others. Or the machine can be lifted by the included Lifting Eye with a forklift.



Figure 10: Unpacking

1. Open the cardboard box, remove the machine base, loose parts, and top foam insert.



Figure 11: Top insert



Figure 12: Bottom insert

2. Cut the box down at the four corners to make the box flat. Cut the end of the bottom, foam insert to access the bottom of the drill press column.

3. Install the machine base, parallel to the head stock, by bolting the base onto the machine column using four M10 x M40 hex bolts from the hardware (packed in the top insert).



Figure 13: Cutting box corners



Figure 14: Installing Base

4. Install the eye bolt by screwing into the top of the head assembly. Cut away foam from head assembly for better access. **IMPORTANT:** Use cloth lifting straps around the column to lift machine from horizontal to vertical. **DO NOT** use the lifting eye for this procedure! The lifting eye is for lifting or moving the machine when it is standing upright (vertical).



Figure 15: Installing Lifting Eye

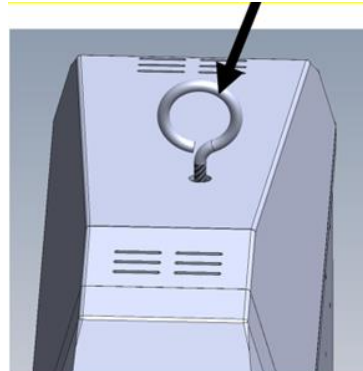

Figure 16: Lifting Eye installed

5. Lift the DP20 out of the packaging. You will need two or more people, as the DP20 heavy. Use cloth lifting straps to assist lifting the machine from packaging. **Do not** use "lifting eye" for this procedure!

6. Remove plastic coverings and clean the anti-rust coatings from the raw cast iron surfaces, using a degreaser such as Simple Green or similar.

\* Do not use gasoline or distillates on or near painted surfaces, which can harm paint!



Figure 17: Removing plastic



Figure 18: Cleaning

7. Clean the coatings from the arbor, quill and chuck interior using mineral spirits or paint thinner, a rag and dowel.

\* Do not touch painted surfaces with distillates!

\* Dispose of rags properly & safely!

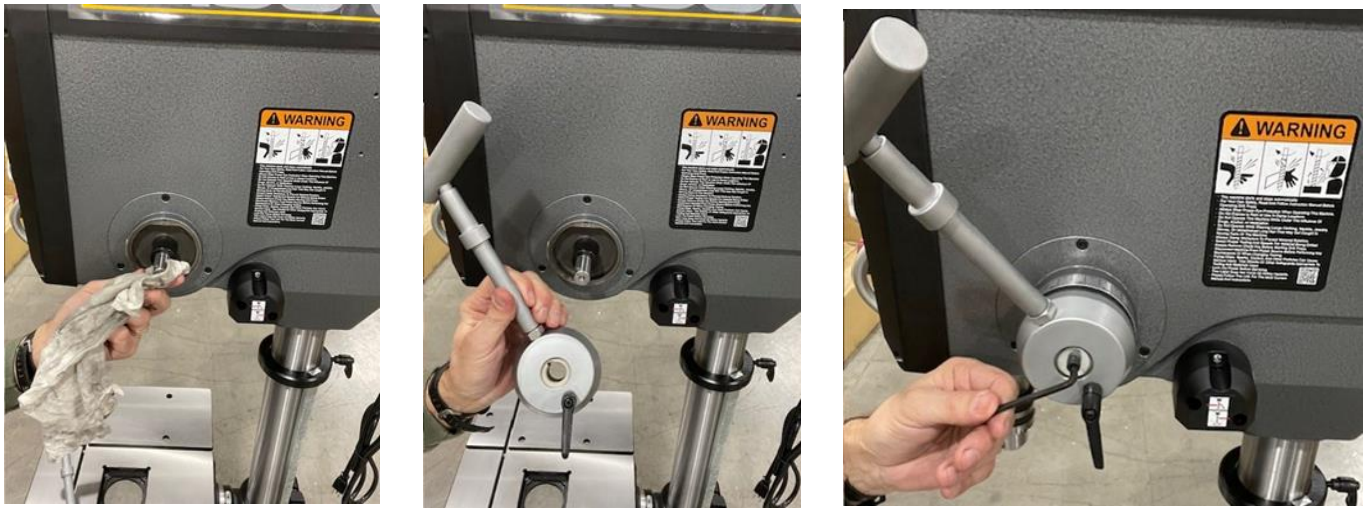

Figure 19: Cleaning Chuck & Arbor

8. Remove the tape from the shaft of the arbor height adjustment mechanism, on the side of the headstock. Clean the shaft and install the depth handle, securing with the bolt and washer.

**Note:** The handle can be installed on the left side of the headstock, by removing the cap, bolt and washer and installing the handle on the left. The cap from the left should then be installed on the shaft on the right side of the headstock.

**Note:** The handle can also be lengthened by loosening the set screw of the handle and sliding to the desired length and tightening the set screw.



Figures 20-22: Installing handle (right or left side)

**9.** Assemble and install the table height adjustment handle, using the 3/8 x 4-1/2" hex bolt, pivot handle and set screw.



Figures 23-26: Crank assembly

**10.Chuck Installation:**

Unplug the machine prior to installing the chuck. Clean the tapered portions of the chuck arbor with mineral spirits and a soft rag to ensure that all oil, grease, or other packing debris are cleaned from the arbor.

Clean the internal taper in the drill press with mineral spirits and a soft rag. Use a dowel or pencil to push the rag into the taper for cleaning. Any debris or residual grease can cause the chuck arbor to not seat properly. Dispose of rags safely!

Rotate the outer ring of the chuck to retract the jaws into the chuck body to prevent damaging the chuck jaws during installation. Your chuck may have come separate or pre-assembled. If pre-assembled, skip to the next step. If separated, assemble the arbor to the chuck by placing the retracted jaw side of the chuck downwards onto the bench and inserting the cleaned arbor into the cleaned tapered opening on the chuck. Use a plastic-coated dead blow mallet, rubber hammer, or a block of wood and hammer to deliver two to three sharp strikes to seat the arbor into the chuck.

**11.** Insert the chuck and arbor assembly into the cleaned taper of the drill press. Make sure that the drill press quill is in the up position. Use a plastic-coated dead blow mallet, rubber hammer, or a block of wood and hammer to deliver two to three sharp strikes to seat the arbor and chuck assembly into the drill press.



Do not use a steel hammer directly against the arbor or chuck. This may cause damage to the chuck and/or arbor.



Figure 27: Chuck with arbor installation

**12.** The DP20 drill press is equipped with a dedicated chuck key holder on the left side of the headstock. The chuck key must be in position in the chuck key holder for the Auto-Start function to operate. This prevents inadvertent starts while using the chuck key in the chuck. If the chuck key is misplaced, the drill press will operate in normal manual mode without Auto-Start capability.



Figure 28: Chuck key holder



## Table Adjustments

### Table Tilt:

The tilt or angle of the table can be adjusted by disengaging the Stop Stud, loosening the Tension Nut and tilting the table to the desired angle. Tighten the tension nut to secure the table in desired position. NOTE: Some models may include a Stop Stud for a 90-degree quick reference (not for precise alignment) and may need to be removed for precision settings of table.

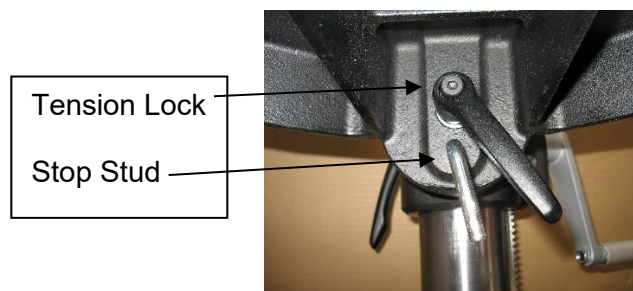

Figure 29: Table Tilt and Tension Lock

### Table Swing:

The Table can be rotated around the column for ideal positioning for many applications. To rotate the table, loosen the three Column Locks and rotate the table, making sure the Rack and Locks rotate with the Table. When the table is in position, tighten all three Column Locks.



Figure 30: Column Locks

### Table Height:

The height of the Table can be adjusted along the length of the Column. To adjust the Table Height, loosen the Column Lock on the Table Support Casting and turn the height adjustment handle to move the table to the desired height. Tighten the Column Lock to prevent the Table from moving.

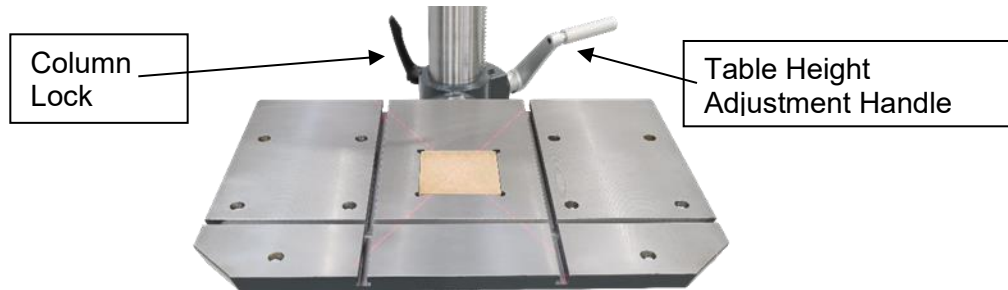

Figure 31: Table Controls

## Table Insert

The machine is supplied with a removable table insert. It is held in position with friction. The table insert can be removed when support is not desired, but through drilling is required. The insert is made of MDF, if the bit contacts the insert, such as for a zero-clearance application, there is less chance of damaging the drill bit. The insert can be removed by grabbing with a fingernail at the divot in the table and lifting. Or it can be pushed up from under the table. The table insert can be leveled with the tabletop by adjusting the four leveling bolts from under the table. Loosen the locking nut and adjust the leveling bolts until the insert is in the desired location and tighten the four locking nuts.

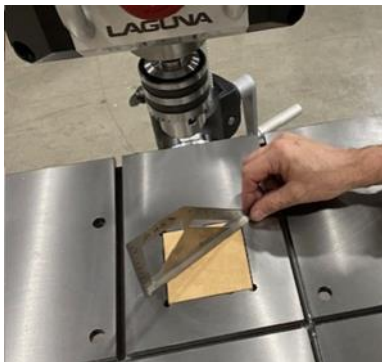

Figure 32: Table insert leveling



Figure 33: Table insert leveling bolts

## Table Clamping

The DP20 table provides several methods for material clamping. Including one side-to-side T-Slot and two front-to-rear T-Slots to use table clamps, fences, jigs, fixtures, or work vises.

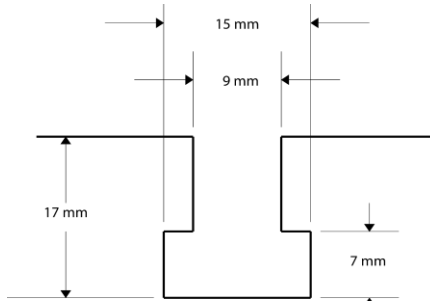

Figure 34: T-Slot dimensions

Ten holes in the table accept various types of clamps with either 5/8 inch or 16 mm posts. Please note that during manufacturing, these holes may get thicker amounts of powder coating material onto the sides of the hole which could prevent some posts from going into the hole. The powder coating can be cleaned out easily by wrapping sandpaper around a dowel, to remove this coating to adjust the fit.

## Before starting the Drill Press

Read and understand the instruction manual before operating the drill press.

1. If you are still not thoroughly familiar with the operation, get advice from a qualified person.
2. Make sure the machine is properly grounded and that the wiring codes are followed.
3. Do not operate while under the influence of drugs, alcohol, or medicine or if tired.
4. Always wear eye protection, safety glasses or a safety shield, and hearing protection.
5. Wear a dust mask; long-term exposure to the fine dust created is not healthy.
6. Remove your tie, rings, watch and all jewelry. Roll up your sleeves to prevent catching clothes.
7. Make sure that the guards are in place and always use them. The guards protect you from contacting the bit.
8. Make sure that the bit has been properly tightened in the chuck.
9. Make sure that the key has been placed into the magnetic key holder on the headstock.
10. Stop the machine before removing scrap from the table.
11. Always keep your hands and fingers away from the bit.
12. Make sure that you use the proper size and type of bit.
13. Clamp the work piece firmly against the table.
14. Turn off the machine if you must back the material out of an uncompleted or jammed operation.

## Electrical Connection

The drill press is supplied pre-wired with a 110V 3-pin plug. It is recommended that it be connected to a 15-amp (min.) dedicated circuit.

Laguna Tools does not recommend connection to GFI/GFCI outlets or circuits. Local codes often require GFI protected outlets in many areas but also often provide exceptions for certain types of applications including connections to industrial machinery or when the outlet is not easily accessible along with other exceptions. Check your local codes for details.

While GFCI outlets offer increased protection, they may not be suitable for all equipment or appliances. Some devices can cause false or nuisance tripping due to their normal operation, while others may experience issues with shared neutrals. In such cases, a non-GFCI outlet or alternative protection method may be more appropriate.

The type of motor and motor electronic controls used in the DP20 machine for speed control, reverse, and auto reverse functions can result in nuisance tripping from the frequency variations. These fluctuations can be misinterpreted by the GFCI device as a dangerous fault, causing it to trip needlessly. GFCIs will often nuisance trip with certain types of loads. For example, many motors will trip the GFCI even though there is no electrical leakage to ground. This is why there are exceptions for certain types of equipment and even circuits like a refrigerator outlet. It is a good idea to have these on a circuit of their own with no GFCI.

## Control Panel

The Control Panel contains the switches for basic functions and can be programmed for specific applications.

### **Basic Controls** (see next figures):

The Control Panel contains the basic switches for the “LED” light, Laser locator, RPM, Rotation direction (Forward/Reverse) & Chuck ON/OFF.



Figure 35: Control Panel

## CONTROL PANEL:

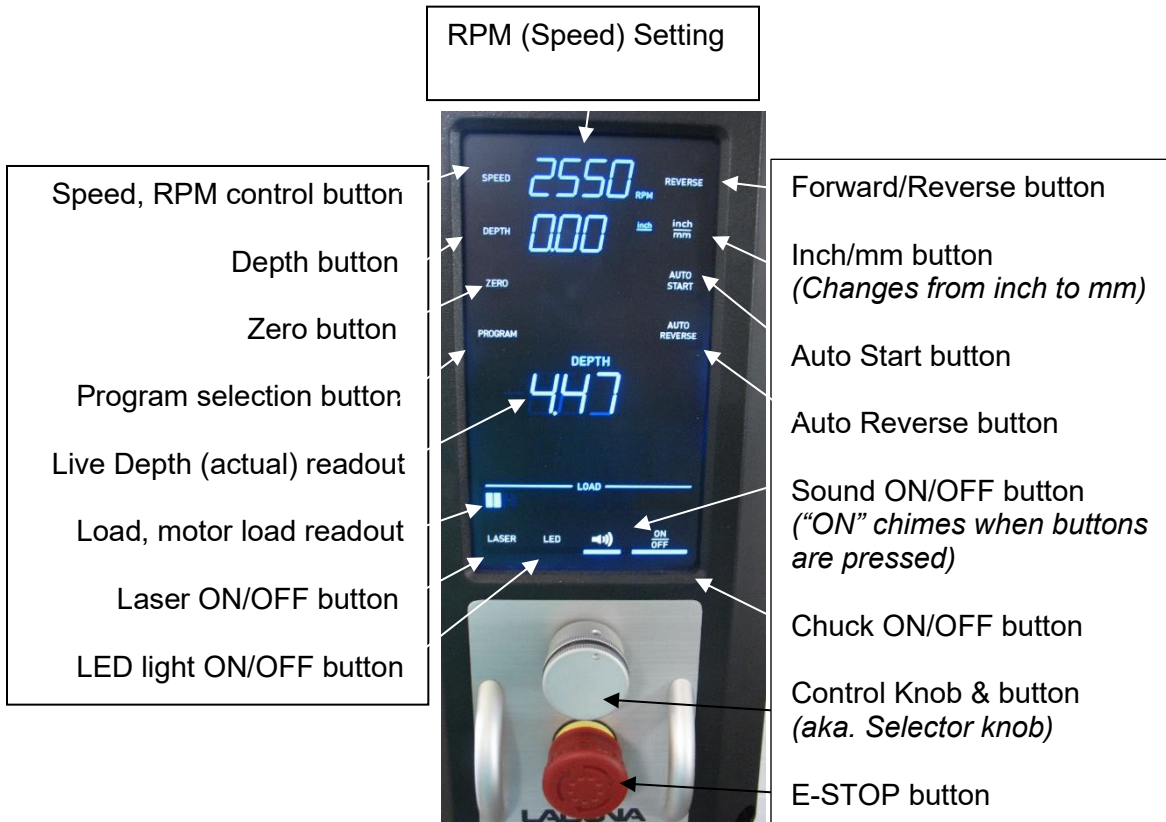

Figure 36: Control Panel

### Quill Zero Setting:

When first setting up your DP20 Drill Press, the Live Depth display should read 0.00 when the quill is at the top of the stroke. If the Live Depth display is reading some other number, follow these steps to return the reading to zero. This is a one-time step during initial setup that isn't required for normal use once set.

1. Check that there is no debris above or below the rubber washer on the quill, between the head casting and the flange on the quill. If there is any debris in this area, lower the quill using the handle, and clean the debris away with a cloth. Return the quill to the top of the stroke, against the head casting and check the Live Depth display. If it reads 0.00, you are finished. If it reads some other number, proceed to step 2. See figure below.

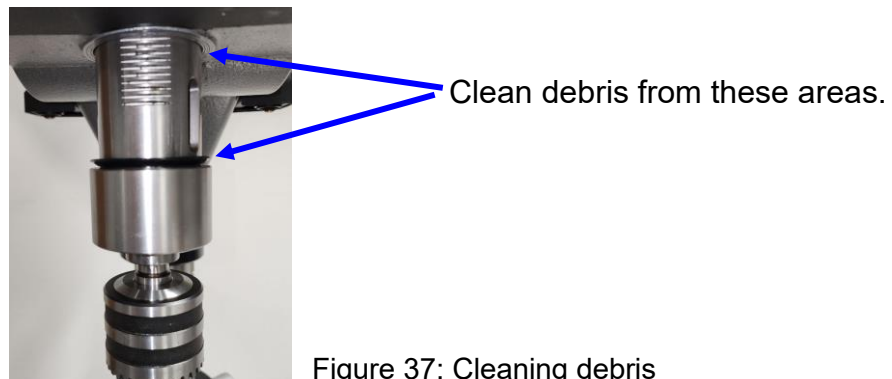

Figure 37: Cleaning debris

2. If, after cleaning debris on the quill (if any), the Live Depth display reads something other than 0.00, cycle the power off and then back on using the switch at the rear of the drill press or the E-stop switch at the front of the drill press. Once the boot up screen cycles off, simultaneously press the Depth button and the Laser button momentarily and then release. The Live Depth display should now read 0.00. Once the setting is reading 0.00 correctly, continue using the drill press normally.

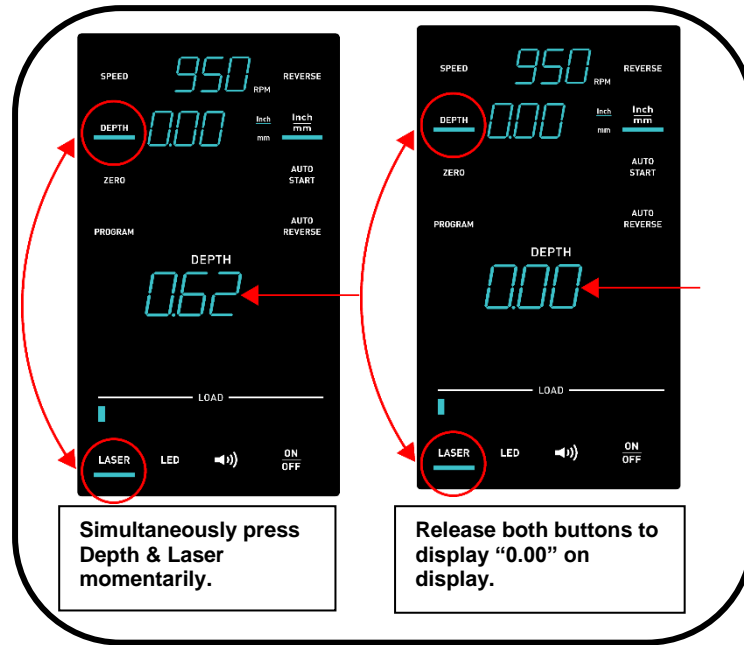

Figure 38: Zeroing Live Depth

If for any reason you need to return to the original setting (non 0.00 number) simultaneously press the Speed button and Laser button momentarily and release. It is unlikely to need to return to this setting.

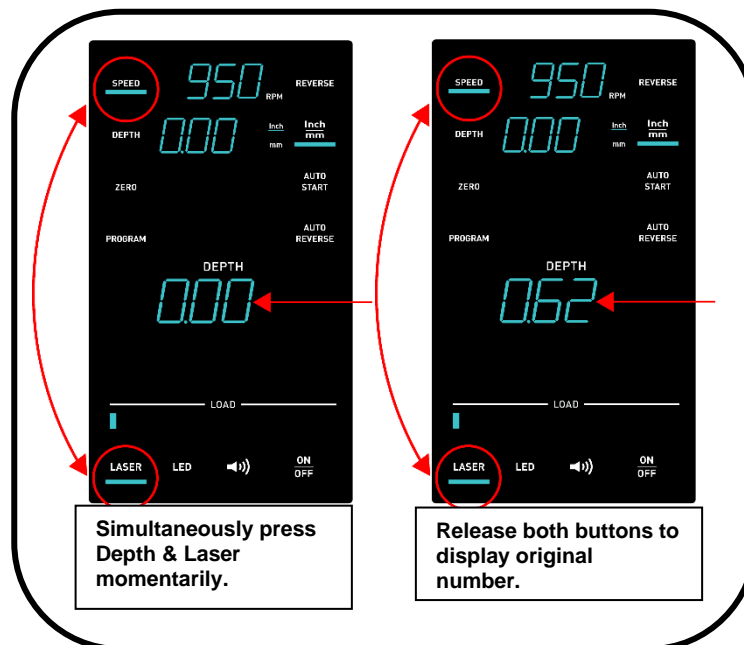

Figure 39: Restoring previous Live Depth display reading

# Programming-Control Panel

Specific and repeatable applications can be achieved with programming within the Control Panel. For example, tapping can be programmed with a specific RPM, stopping point and then reversing to back a tap out of the newly threaded hole.

The DP20 touch screen will illuminate all the lit elements of the screen during start up. This momentary illumination is a normal part of the boot up sequence.

After start up the screen will return to normal operation screen with the settings from the previous use. If the previous settings are not saved in memory, the screen starts with normal default settings.

Certain settings will always return to default settings when the drill press is powered on. The motor ON/OFF button will default to the Off position so that the drill press motor does not start inadvertently. The Tone button will default to the On position so that button presses are accompanied by an audible tone. This button can be turned off if desired when using the drill press. The default increment display setting is in decimal inches. The Auto Start feature will default to the Off position if the drill press has been turned off or unplugged.

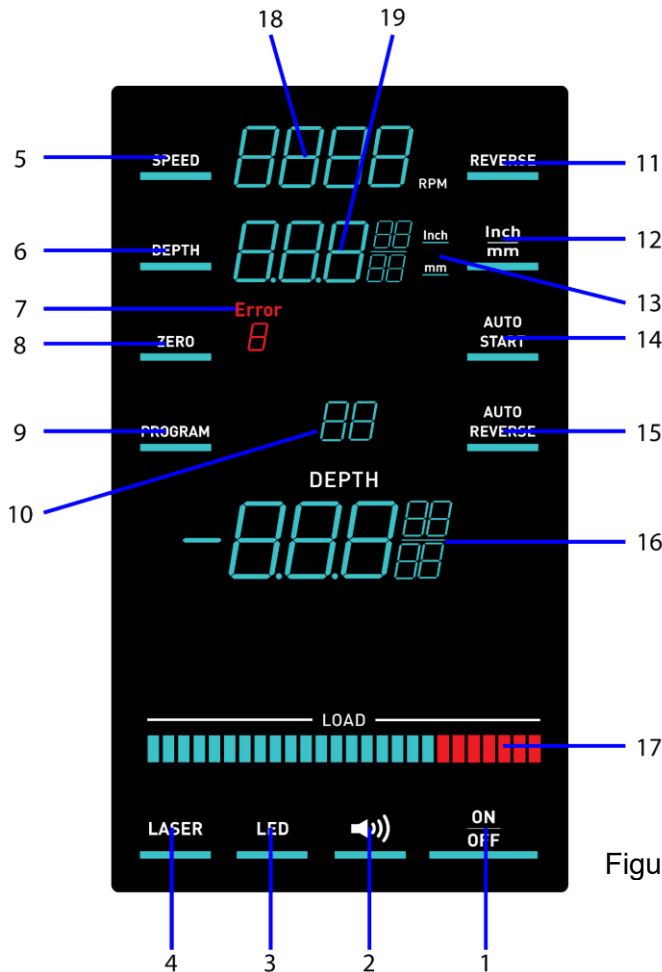
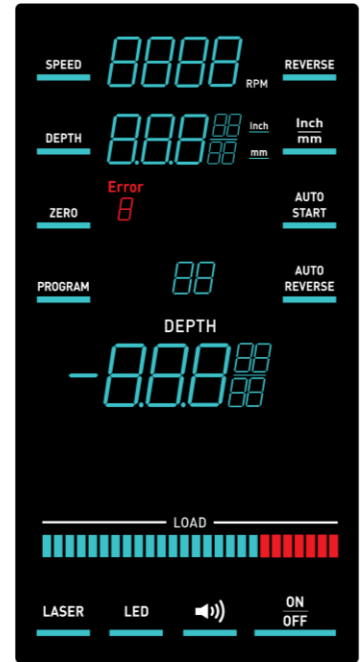

1. Motor ON/OFF button
2. Touch screen Tone button
3. LED work light ON/OFF button
4. Crosshair laser ON/OFF button
5. Speed setting button
6. Depth setting button
7. Error code display
8. Material surface Zero setting button
9. Program mode and selection button
10. Program number display
11. Forward/Reverse button
12. Increment display selector button
13. Increment in use display
14. Automatic motor start button
15. Automatic reverse selection
16. Live depth display
17. Motor load meter
18. Drill speed RPM display
19. Depth setting display

Figures 40 & 41: Control Panel Programming

## **Button Functions/Touch Screen Displays:**

Each of the touch screen buttons has an illuminated “teal/blue” colored indicator bar below the button. When the indicator bar is illuminated, the feature is active, selected, or in the On position. When the indicator bar is off, the feature is not active.

1. **Motor ON/OFF Button** - Starts and stops the drill motor when in manual mode by pressing the button once to start and another time to turn off. When used in conjunction with the Auto Start feature, the Auto Start button must be pressed to activate Auto Start and the Motor ON/OFF button must be pressed to turn it on and light up the indicator bar on the button. The motor will not start until the quill handle is pulled to move the drill bit downwards.
2. **Tone Button** - The Tone Button turns the audible tone on and off. The tone sounds when the touch screen buttons are pressed and provides an audible confirmation tone of button selections. This function defaults to the On position when turning power on to the drill press. Pressing the button will turn the tone off and will turn off the selection indicator bar.
3. **LED Button** - The DP20 drill press is equipped with an LED work light that illuminates the table work area. The LED Button turns the light on and off. The LED defaults to the Off position after the power has been turned off to the drill press.
4. **Laser Button** - Turns the crosshair lasers on and off. The lasers default to the Off position after the power has been turned off to the drill press.
5. **Speed Button** - Used when setting speeds in the programming mode. After pushing and holding the Program Button #9 to select the programming mode, touch the Speed Button so the indicator bar flashes. Now adjust the desired speed for the selected program by rotating the selector knob below the touch screen. When the desired RPM displays, confirm the setting by pressing either the Speed Button or the Selector Knob. The speed range is from 60 to 3600 RPM.
6. **Depth Button** - Used when setting the depth in the programming mode. This is most often used when setting the depth for the bottom of the hole when tapping and using the Auto Reverse function so the tap will stop and then back out of the hole before bottoming out. When tapping, it is recommended to set this value less than the drilled hole depth, so the tap does not bottom out. After pushing and holding the Program Button #9 to select the programming mode, touch the Depth Button so the indicator bar flashes. Now adjust the desired depth for the selected program by using the selector knob below the touch screen. When the desired depth is displayed, confirm the setting by pressing either the Depth Button or the Selector Knob.
7. **Error Indicator/Error Code** - Displays error codes. Some examples of errors are: Selecting RPM higher than the 600 RPM limit when using the Auto Reverse function, Error 9 - when the chuck key is out of the chuck key holder when Auto Start function is selected. **See next section “Error Codes” for details.**

- 8. Zero Button** - Sets the depth display to Zero when at the material surface. Before drilling, lower the bit down to the surface of the material and press the Zero button. This will set the depth display to zero at the top of the material. Once the zero point is set and the drilling begins, the depth display will show negative values when drilling into the material and positive numbers above the material. The zero point can also be set at the top of the quill stroke.
- 9. Program Button** - Toggles the drill press from Manual Mode to Program Mode. The drill press defaults to the manual mode where RPM speed can be changed at any time using the selector knob below the touch screen. A Short Press of the Program button will pull up the saved program files and will display the program number in the Program Indicator portion of the screen as P1, P2, P3, etc. There are 5 available positions to save programs. A Long Press of the Program button enters the Programming Mode to save selected settings into program files that can be recalled for use later. To save a program file, short press the Program Button to enter program mode. Rotate the selector knob below the touch screen to select the program number you wish to use to change. Once you have the correct program file selected (P4 for example), press and hold the Program button until it begins to flash. The P4 and Program Button indicator will remain flashing while the settings are entered. Set desired RPM by touching the Speed Button to start it flashing, change the RPM using Selector Knob below the screen. Confirm the selected RPM by pressing in on the Selector Knob or the Speed button to save the speed. Set the material zero point by lowering the bit to the material surface and pressing Zero Button. Set the depth by pressing the Depth Button so the depth flashes. Select desired depth setting by using the Selector Knob below the screen. Confirm the selected depth by pressing the Selector Knob or the Depth button to lock in the desired depth. Change any other settings for this program like Auto Start, Auto Reverse, etc. Finally save the program with a short press to confirm these values for this program file. While in Program Mode, users can scroll between each of the 5 program files and the settings for each of these files will change as each new program file is displayed. To exit Program Mode, a single press of the Program Button will return the drill press back into manual mode.
- 10. Program Indicator** - Displays the saved program number that is selected. There are 5 available program presets to save commonly used settings. Each program is displayed as P1, P2, P3, etc. The Program Indicator is only displayed when in Program Mode.
- 11. Reverse Button** - The drill press normally operates in the forward direction for standard drill bits. It can also operate in reverse for left-handed drill bits or for other uses. To change from forward to reverse, simply press the Reverse button. The indicator bar will illuminate to let the user know that the drill press is in reverse.
- 12. Inch/mm Button** - The Inch/mm button is used to toggle between 3 different increment modes. Each press of the button will select the next mode. There are two Inch modes, and one mm mode. Inches can be displayed as Decimal Inches or Fractional Inches. When in either decimal or fractional inches, the Increment Indicator will illuminate the Inch indicator. Millimeters are shown as decimal mm. The mm indicator will illuminate when in the mm selection. The drill press will default to Decimal Inch.

- 13. Increment Indicators** - The indicator bar will illuminate under the selected measurement increment, either Inch or Millimeter (mm). The Inch indicator will be illuminated for either Fractional Inches or Decimal Inches.
- 14. Auto Start Button** - Used for repeated hole drilling to automatically start the spindle when pulling down on the quill stroke handle. When the Auto Start function is selected, the indicator bar will be illuminated. The motor ON/OFF button must be in the ON position for the Auto Start feature to work. If the ON/OFF button is in the OFF position, the motor will not start when the Auto Start function is active. The chuck key must be in the chuck key holder for the Auto Start function to operate. This is a safety so that the chuck does not start spinning when Auto Start is selected while users are tightening or loosening the chuck. Error 9 will display on the touch screen if the Auto Start button is on and the chuck key is not in the holder. The drill press will not start when the chuck key is out of the holder AND if Auto Start is selected. The drill press will default to Auto Start Off when the drill press is powered on after being shut off or unplugged.
- 15. Auto Reverse** - The Auto Reverse function is most often used when tapping to back the tap out of the hole after reaching the bottom. When the Auto Reverse function is selected, the illumination bar under the button will be lit. The RPM speed is limited to 600 RPM when using the Auto Reverse function to help prevent tap breakage. An error will display if Auto Reverse is selected, and the speed is set faster than 600 RPM. Pre-drill the correct hole size for the tap you will use. When tapping using the Auto Reverse function, start the tap into the hole by pulling down on the quill stroke handle. Once the tap is started, it will pull itself down into the hole until it reaches the preset depth setting. Once it reaches the preset depth, the auto reverse function will immediately reverse the bit and back it out of the hole. For best results, use matched drill/tap sets, use proper RPM for the size and type of drill and tap used, lubricate drill/tap with appropriate tapping fluid, and provide extra space at the bottom of a blind hole so that the tap does not bottom out.
- 16. Live Depth Display** - Displays the actual depth value during the quill travel. The default zero point is at the top of the quill stroke. The display can be zeroed out at the material surface by lowering the drill bit to the material surface and hitting the Zero button. When the display is zeroed out at the material surface, the display will show negative values once drilling into the material.
- 17. Load Meter Display** - The load display will illuminate all the load bars during start up and will return to a single bar when there is no load. The number of load bars displayed will increase when drilling as the load increases. This is particularly noticeable when using larger diameter drill bits, when drilling difficult materials, or if the RPM is incorrect for the specific bit and material being drilled. Dull drill bits can also cause the load meter to read higher than expected. If the display is showing loads in the Red Zone when drilling, stop to inspect the bit, materials, RPM selected, or reduce the quill feed pressure. If the Red indicators are still displaying after checking these items, contact Laguna Customer Service for assistance.

**18. Speed Display** - Displays the RPM speed selected for the drill chuck. The speed can be changed when in manual mode (normal mode) by turning the selector knob below the touch screen. The Speed Display will also display the desired speeds when setting the speeds in the Program mode.

**19. Depth Setting Display** - Displays the desired depth selected when using the Program Mode.

## Error Codes-Control Panel

The DP20 control panel is equipped with an error display. Under normal operation, the red error display will illuminate during the screen startup sequence when all the lights on the touch screen illuminate momentarily as a test. After the startup sequence, the error display should go off and remain off during normal drill press operation unless certain events trigger the Error display.

A few common error displays will illuminate or sound frequently during normal drill press operations that will require user input to clear:

- **Error 9** - This displays any time the chuck key is removed from the chuck key holder on the left side of the drill press headstock. The chuck key holder is equipped with a switch that prohibits the use of the Auto Start feature any time that the chuck key is removed from the chuck key holder. This is to prevent the drill press from automatically starting when using the chuck key on the chuck and unintentional downward movement of the quill occurs during tightening or loosening of the drill bit with the chuck key. This error will automatically go out when the chuck key is returned to the chuck key holder. The drill press will operate normally with the chuck key out of the holder except for the Auto Start function.
- **Audible Error** - The DP20 will have an audible beeping tone when Auto Reverse is selected AND the speed setting is above 600 RPM. The RPM limit for Auto Reverse is 600 RPM to reduce the chance of breaking a tap when reversing out of a tapped hole. The audible beeping error tone will go away when either the RPM is set to 600 or less or when the Auto Reverse is deselected.
- **Other Error Codes** - Other error codes may display during operation which can be triggered internally by communication errors between the display controller and display MCU or motor driver. Some errors may also indicate open circuits, under or over voltage. These errors should be noted and communicated to a Laguna Tools Customer Service representative who can assist with a complete diagnosis and repair if needed.

## Selecting RPM / Drill Speed

To adjust the drill press RPM, select the “SPEED” setting on the Control Panel. The light bar next to the switch will light up and flash. While the light bar is flashing rotate the Control Knob until the desired RPM is reached.



Figure 42: Speed Setting (RPM)

### RPM / Drill Speeds:

The DP20 drill press has an RPM speed range from 60 to 3600 RPM. Select the correct speed for the type and size of bit being used and the material being drilled. Use the drill speed chart below or on the side of the machine to select the correct speed for various types and sizes of bits. Please note that this speed chart should be used as a starting point for certain bits or operations and adjustments may be needed to the RPM for specific types and sizes of bits or for certain operations and accessories. Consult specifications from the bit or accessory manufacturer or from a machinists' guide for additional information, settings, or recommendations.

The RPM setting is limited to 600 RPM when using the Auto Reverse function to help prevent tap breakage and is typically much slower.

As general rules of thumb, smaller drill bits require higher RPM settings, softer materials use higher RPM while harder materials use slower RPM.

Next is an RPM (speed) selection chart. These are basic suggestions for RPM selection. Keep in mind that your conditions and parameters may require other settings for optimum performance.

# RPM / Drill Speed Chart

TOOLING			MATERIAL					
Bit Type	Tool Diameter		Soft Wood	Hard Wood	Acrylic	Brass	Aluminum	Steel
	Inches	mm						
Twist Drill	1/16 - 3/16	1 - 5	3000	3000	2500	3000	3000	3000
	1/4 - 3/8	6 - 10	3000	1500	2000	1200	2500	1000
	7/16 - 5/8	11 - 16	1500	750	1500	750	1500	600
	11/16 - 1	17 - 25	750	500	-	400	1000	350
Brad Point	1/8	3	1800	1200	1500	-	-	-
	1/4	6	1800	1000	1500	-	-	-
	3/8	10	1800	1250	1500	-	-	-
	1/2	13	1800	1250	1000	-	-	-
	5/8	16	1800	500	1250	-	-	-
	3/4	19	1400	250	1250	-	-	-
	7/8	22	1200	250	500	-	-	-
1	25	1000	250	250	-	-	-	
Bullet Pilot Point	1/8 - 3/16	3 - 5	3000	3000	3000	2000	1500	3000
	1/4 - 3/8	6 - 10	3000	3000	2400	1500	100	2000
	1/2	13	3000	1500	1600	1500	750	1200
Spade Bits	1/4 - 1/2	6 - 13	2000	1500	-	-	-	-
	5/8 - 1	16 - 25	1750	1500	-	-	-	-
	1 1/8 - 1 1/2	29 - 38	1500	2000	-	-	-	-
Spade Bits with Spur	3/8 - 1	10 - 25	2000	1800	500	-	-	-
Hole Saw	1 - 1 1/2	25 - 38	500	350	-	250	250	-
	1 5/8 - 2	41 - 51	500	250	-	150	250	-
	2 1/8 - 2 1/2	54 - 64	350	100	-	150	250	100
Circle Cutter	1 1/2 - 3	38 - 76	500	250	250	-	-	-
	3 1/4 - 8	83 - 203	250	250	250	-	-	-
Forstner	1/4 - 3/8	6 - 10	2400	800	-	-	-	-
	1/2 - 5/8	13 - 16	2400	500	250	-	-	-
	3/4 - 1	19 - 25	1500	500	250	-	-	-
	1 1/8 - 1 1/4	29 - 32	1000	250	250	-	-	-
	1 1/8 - 2	35 - 51	500	250	-	-	-	-
2 1/8 - 4	54 - 102	250	250	-	-	-	-	
Power Bore	3/8 1/2	6 - 13	1800	500	-	-	-	-
	3/4 - 1	19 - 25	1800	750	-	-	-	-
Shear Cutting Countersink	1/4 - 3/8	6 - 10	1000	1000	700	850	850	-
Countersink	2 Flute		1400	1400	-	-	-	-
	5 Flute		1000	750	750	250	250	250

The information on this sheet is intended as a general guide only. Figures will vary with grades of material and tooling used. Figures will vary based on machine capabilities. It is best to start with moderate speeds and feeds, increasing or decreasing either one or both after observing the cutting action and condition of the drill bit and the material.

Figure 43: Speed Chart (RPM selection)

## Drill Bits

The selection and use of bits is a very extensive subject, and there have been many books written on the subject. This section of the manual is intended as a general guide only.

## Selecting a Drill Bit

Using the correct bit is important. Several factors need to be considered when choosing the Correct bit or bits for an application.

- Size of hole, diameter, and depth.
- Depth of desired hole.
- Material of stock to be drilled (hardness, pitch, grain, voids, etc.)
- Material and/or coating of bit.
- Sharpness of bit.

## Causes of Drill Bit breakage

Bits can break from over-feeding of bit, being dull, incorrect RPM, “skipping” of the bit as it is introduced into the stock, especially if drilling at an angle.

## Installing and removing a Drill Bit

1. Disconnect the power to the drill press.
2. Using the key, loosen the chuck.
3. Place the bit into the center of the chuck.
4. Tighten the chuck, using the key or hand pressure.
5. Place the key into the magnetic key-holder on the left side of the headstock.



**Always replace the key into the magnetic key holder after every use.  
Never leave key in chuck, as it could cause injury or catch clothing.**

NOTE: Key must be inserted into magnetic key holder for Auto Start Function to engage.



Figure 44: Chuck Key Holder

6. When the chuck jaws are holding the bit in place, tighten securely using the key. Making sure the chuck jaws are not touching the flutes of the bit.
7. To remove the bit, loosen the chuck, using the key while holding the bit with a rag, to prevent the bit from dropping out of the chuck.

## Setting the Depth Stop

The Depth Stop can be adjusted for setting a specific depth for non-through holes. With the machine OFF, and drill bit installed, lower the drill bit to the desired height. While maintaining the drill bit location, tighten the Depth Stop Locking Knob.

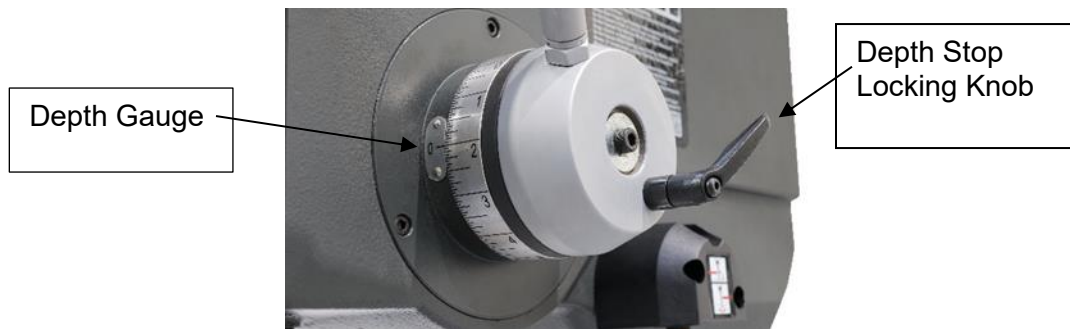

Figure 45: Depth Stop & Gauge

## Laser Light



**Never look at the source of laser light! Eye damage is possible.**

Included with your drill press is a Laser Light locator. When turned ON, it will form a cross hair where the drill bit will engage the material to be drilled. The Laser Light control button is found at the bottom of the Control Panel.

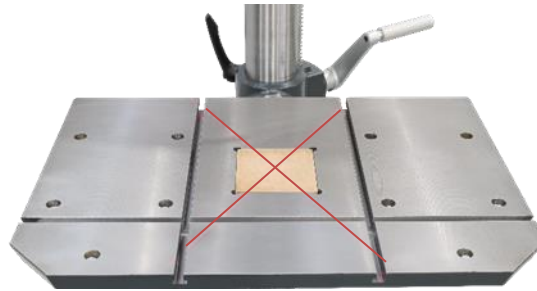

Figure 46: Laser Light indicator

### **Laser Adjustment:**

The alignment lasers are pre-set at the factory during production. These lasers can go out of alignment during transportation and assembly and should be checked and adjusted if necessary after machine assembly. They should be checked periodically and adjusted as needed during regular maintenance intervals.

Before checking and adjusting the lasers, check to make sure that the drill press table is leveled and locked in the horizontal position. Install a small drill bit into the chuck. Turn on the lasers by pressing the Laser button on the touch screen. Leave the lasers on during the adjustment procedure. Lower the drill bit down toward the table and observe the position of the tip of the drill bit relative to the center point of the crossed lasers.

### **Laser Vertical Adjustment:**

To adjust the lasers, use a short board with flat, square edges for the adjustment. Mark a perpendicular line on the board using a square and a sharp pencil.

Place the marked board onto the table with the square edge to the bottom and the surface with the perpendicular line toward the rear of the drill press. Observe the vertical laser line on the back of the board in relation to the vertical pencil line. Slide the board side to side as needed to bring the pencil line adjacent to the vertical laser lines. Select the laser on one side of the drill press to adjust first. Using a Phillips screwdriver, rotate the vertical adjustment screw toward the front of the drill press to adjust the verticality of the laser line. Turn the screw as needed to align the laser line with the vertical mark on the board.

Adjust the laser on the other side of the drill press in the same manner using the vertical adjustment screw toward the front of the drill press. Slide the board from side to side as needed to meet up with the laser line. Once the vertical adjustments are set, both laser lines should be vertical and should match the vertical line drawn on the board.

### **Laser Crosshair Alignment:**

Place the board flat onto the table. Do not allow the board to move from this position during the adjustments. Clamp in place if needed. Lower the drill bit down to the surface of the material and leave a small dimple in the surface of the wood. Raise the drill bit back up out of the way.

Select one of the laser modules to adjust first. Adjust the crosshair adjustment screw on the laser which is toward the rear of the drill press. Adjust this screw as needed to bring the laser line directly over the dimple in the board.

Adjust the laser on the other side of the drill press in the same manner until both lasers cross directly over the dimple in the wood.

Re-check the vertical adjustment by standing the board vertical again and observing the vertical lines on the rear of the board to ensure that the vertical adjustments did not shift during the adjustment. Set vertical adjustments again if needed. The crosshair lasers are now properly calibrated to ensure exact centering for accurate drilling of holes.

Laser Emitter,  
right



Figure 47: Laser Light Emitter, right (1 of 2, left)



## Using the drill press

Install desired drill bit, tap, or appropriate tooling into chuck.

Tighten Chuck with Key, replace key into magnetic holder.

Adjust the table (height, swing & angle) and tighten all locks and tension bolts.

Turn ON LED light if needed for this application.

Position workpiece on table.

Turn on Laser Light if using to position stock.

Clamp workpiece onto table. Three T-slots and ten holes are designed, into the table, for attaching clamps.

Set and lock Depth Stop, if required for the drilling application.

Confirm Main Power Switch is ON (on back of headstock).

Confirm E-Stop is not engaged.

The Control Panel should be lit up.

Choose drilling/tapping program or select & adjust RPM.

Turn ON power button (chuck should start to rotate)

Wait until Actual RPM has matched Selected RPM before engaging bit/tap.

Engage bit/tap with smooth even pressure on handle.

When drilling is completed, return the handle to upper/resting position.

Turn OFF chuck.

**Be careful when removing the workpiece that chuck has stopped rotation and confirm stock is not too hot or sharp to handle!**

**When complete, turn OFF laser, illumination light(s) and turn main power OFF.**

## Maintenance

All tools and machines require regular maintenance, and the drill press is no exception. This section details the general maintenance and care. In general, we recommend that you only use a Teflon-based lubricant. While regular oil attracts dust and dirt, Teflon tends to dry and has fewer tendencies to accumulate dirt and dust on your machine.

### **Chuck & Arbor Removal:**

Unplug the machine prior to removing the chuck. Lower the quill assembly using the down feed lever to expose the slot on the side of the quill. Rotate the chuck by hand to align the slots inside the quill. Insert the tapered end of the included drift key into the slots. Tap the drift key sharply with a dead blow mallet, rubber hammer, or hammer until the chuck and arbor are loosened and fall out of the bottom of the quill. Caution - Hold onto chuck while loosening so that it does not fall out onto the drill press table or floor. Alternatively, place a thick towel onto the drill press table to catch the chuck.

### **Table Insert:**

The table insert is made of MDF and is designed to reduce damage to a bit should they come in contact. If the hole in the insert becomes too large or the insert becomes damaged, it should be replaced. The replacement insert will have to be fitted to the tablehole. The insert is adjusted with four leveling bolts that can be adjusted so that the insert is level with the top of the table.

### **Bearings:**

All bearings are sealed for life and do not require any maintenance. If a bearing becomes faulty, replace it.

### **Preventing Rust:**

The drill press is made of steel and cast iron. All non-painted surfaces will rust if not protected. It is recommended that the table be protected by coating it with wax or other cast iron protectant if the machine is not in constant use. All moving non-painted surfaces (guides, rack, and pinion, etc.) should be lubricated/protected with a Teflon-based lubricant.

### **Adjusting the table square to a bit:**

The table has a reference stop stud that is used to quickly align the table to zero degrees. The stop stud slides into a mating hole in the table support casting. When the stud is pulled away from the hole, and the tension nut is loosened, the table can be tilted left or right. Tightening the tension nut allows the table to hold a tilted position.

# Troubleshooting

## **Drill Press will not start:**

1. Check that the electrical power cord is plugged into the power outlet.
2. Check that the start switch is fully lifted (back of headstock).
3. Check that the yellow safety plug is fully engaged (back of headstock).
4. Check that the red E-Stop button is disengaged (front of headstock).
5. Check that the ON switch on the Control Panel has been turned on and is lit up.
6. Check that the electrical supply is on (reset the breaker).
7. Check that you have the correct power, 110-120V, 15 amp (min.).

## **The machine will not stop:**

This is a rare occurrence, as the machine is designed to be fail-safe. If it should occur, and you cannot fix the fault, seek professional assistance. The machine must be disconnected from the power and not run until the fault has been rectified.

1. Stop switch faulty. Replace the stop switch.
2. Internal breaker faulty. Replace the breaker.

## **Bit overheats:**

1. Dull bit. Replace the bit or sharpen the bit.
2. Excessive RPM for application, reduce RPM.
3. Excessive penetration speed, slow bit advancement.
4. Use of lubricant required for type of drilling/application.
5. Incorrect type of bit for the application, change to correct bit type.

## **Machine vibrates:**

1. Machine not level on the floor. Re-level the machine ensuring that it has no movement.
2. Bearings worn, replace bearings.

## **Error Codes:**

See "Error Codes -Control Panel", page 32.



# DP20 Head Assembly exploded view

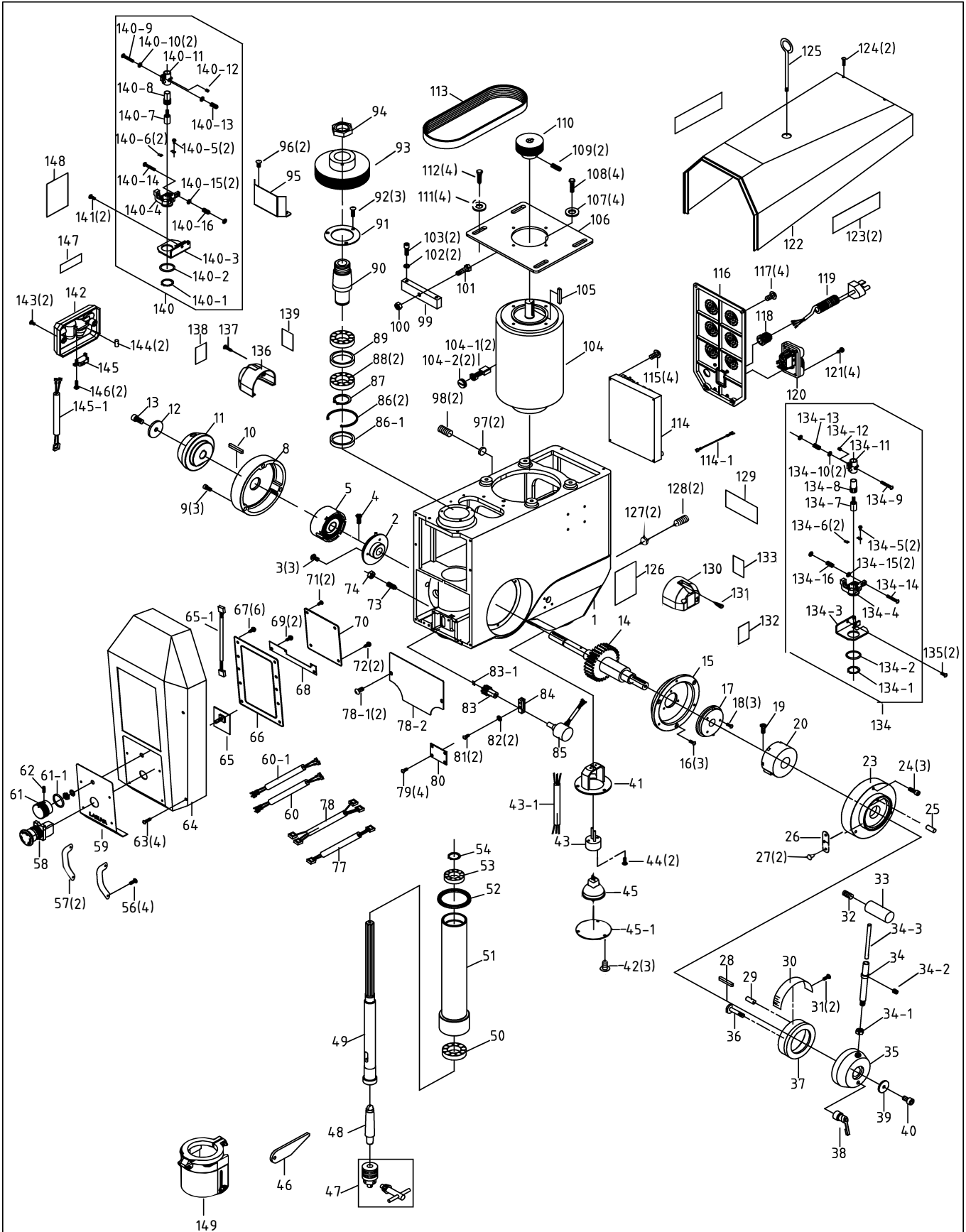

CSA  
DP-20-2025-R8 20250523

# DP20 Table, Base & Column exploded view

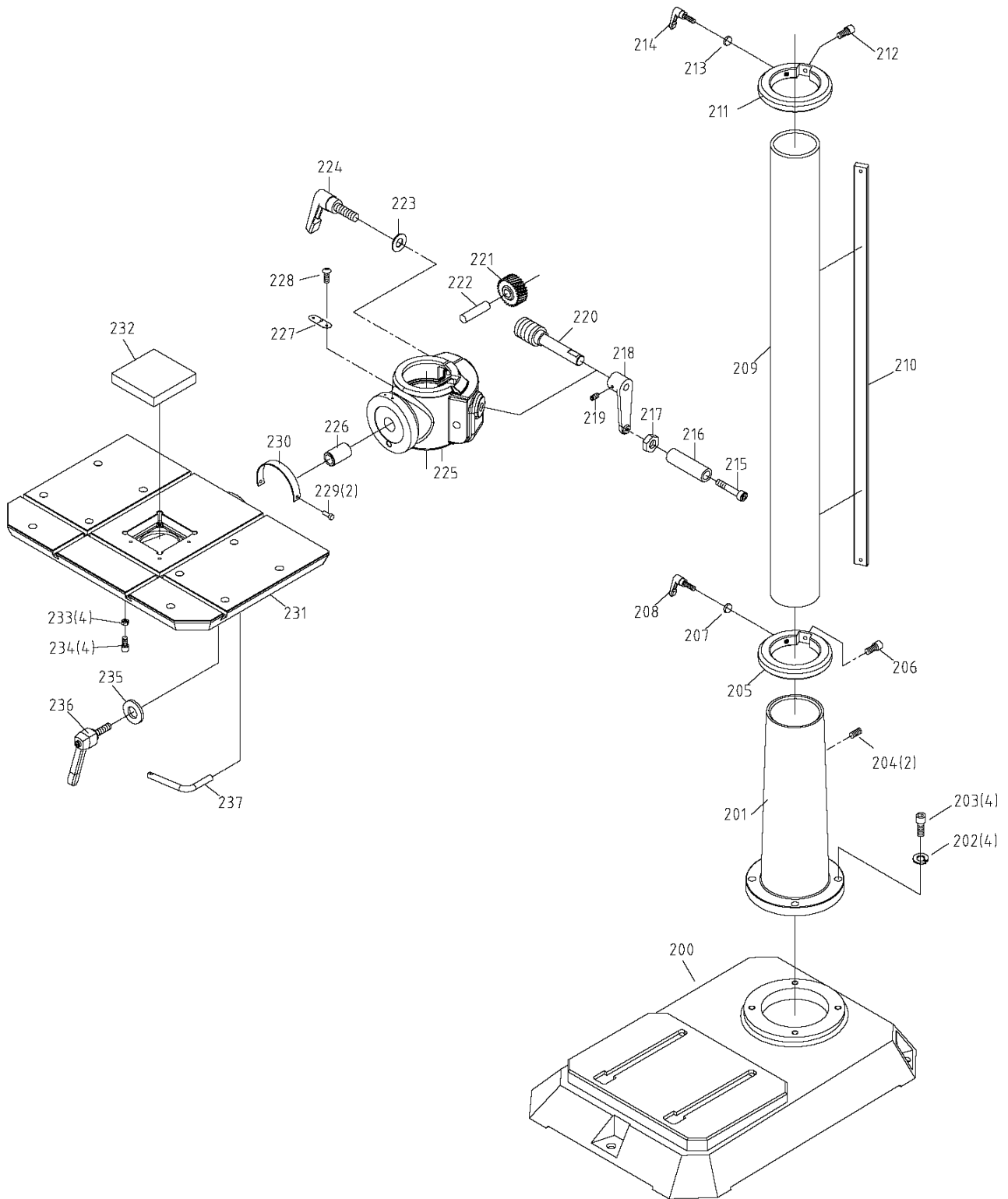

## DP20 Parts List

Ref No.	Part No.	Specification	Description	Qty.
1	272001A		Machine Head	1
2	272082S		Spring Cover Set	1
3	HS519	M5x10L	Cross Round Head Screw	3
4	S307	3/16"x1/2"L	Flat Cross Head Screw	1
5	61103S		Spring Cover Set	1
8	272059A		Cover	1
9	HS223	M5*35L	Hex. Socket Head Screw	3
10	MHK027	6x6x30L	Key	1
11	272022A		Handle Body	1
12	W025	⌀ 1/4"* ⌀ 25*T2	Washer	1
13	HS228	M6x10L	Hex. Socket Head Screw	1
14	272020B		Pinion Shaft	1
15	272069		Pinion Shaft base	1
16	HS519	M5x10L	Cross Round Head Screw	3
17	272082S		Spring Base Set	1
18	HS520	M5x15L	Cross Round Head Screw	3
19	S307	3/16"x1/2"L	Flat Cross Head Screw	1
20	272079S		Spring Cover Set	1
23	272059A		Cover	1
24	HS222	M5*30L	Hex. Socket Head Screw	3
25	2450051	⌀ 4x13L	Pin	1
26	272108		Limit Plate	1
27	HH001	⌀ 2	Rivet	2
28	MHK027	6x6x30L	Key	1
29	2450051	⌀ 4x13L	Pin	1
30	272106		Scale	1
31	HH001	⌀ 2	Rivet	2
32	HS431	M8x16L	Hex. Socket Headless Screw	1
33	272070A		Handle	1
34	272056A		Handle Rod A	1
34-1	N001	1/2"	Hex. Nut	1
34-2	HS421	M6x6L	Hex. Socket Headless Screw	1
34-3	272057		Handle Rod B	1
35	272022A		Handle Body	1
36	2450033A		Scale Base Set Screw	1
37	272145		Graduated Dial	1
38	2450063		Graduated Base Fixed Grip	1
39	W025	⌀ 1/4"* ⌀ 25*T2	Washer	1

40	HS228	M6x10L	Hex. Socket Head Screw	1
41	272152		Light Base	1
42	HS519	M5x10L	Cross Round Head Screw	3
43	MET2429		LED Light Base With Latch	1
43-1	ME060201		Connect Cord	1
44	HS803	M3x15L	Self-Tapping Screws	2
45	MET2222	5W	LED Light	1
45-1	272175		Cover	1
46	6168		Drift Key MT2	1
47	272129	JT3 5/8"(3~16MM)	Drill Chuck Set	1
47-1	272129		Drill Chuck	1
47-2	272129-1		Chuck Key	1
48	272100	MT2//JT3	Chuck Arbor	1
49	272014A		Spindle Shaft	1
50	CA6205ZZ	#6205-ZZ	Bearing	1
51	272015		Rack Sleeve	1
52	668037	φ 55x φ 80x3t	Rubber Flange	1
53	CA6204LU	#6204-LU (TPI)	Bearing	1
54	HCS09	S20	C-Retainer Ring	1
55				
56	HS503	M3*10L	Cross Round Head Screw	4
57	163061		Handle	2
58	MET1245F		Emergency Switch	1
59	272066		Emergency Switch Plate	1
60	ME100252B		Emergency Cord 1	1
60-1	ME100252C		Emergency Cord 2	1
61	272048A		Operation Knob Set	1
61-1		P29 ( φ 28.7* φ 3.5 N70)	O-ring for Knob	1
62	HS408	M4*8L	Hex. Socket Headless Screw	1
63	HS521	M5*20L	Cross Round Head Screw	4
64	272034A		Front Cover Plate	1
65	MBS-HALL-001	TRI Hall-01		1
65-1	ME021501		Connection Cord	1
66	MBS-DIS-001	100~115V//20A//RFI-DIS-02	Operation Panel	1
67	HS802	M3*10L	Self-Tapping Screws	6
68	272085		Fixed Plate	1
69	HS801	M3*6L	Self-Tapping Screws	2
70	MBS-VR-001	100~115V//20A//RFI-END-01	Panel Base Plate	1
71	HS502	M3*P0.5*5L	Cross Round Head Screw	2
72	HS801	M3*6L	Self-Tapping Screws	2
73	272013		Screw Key	1
74	HN006	M10	Hex. Nut	1
77	ME080201		Connection Cord	1
78	ME080C01		Connection Cord	1
78-1	HS519	M5x10L	Cross Round Head Screw	2
78-2	272168		Protective Plate	1
79	HS519	M5*10L	Cross Round Head Screw	4
80	272062		Gear Cover	1

81	HS510	M4x15L	Cross Round Head Screw	2
82	HW102	M4	Spring Washer	2
83	272041A	#83,83-1,84,85 have to order	Mini Gear	1
83-1	272173	as a set for part number #SM72A029	File	1
84	272023A		Fixed Base for Mini gear	1
85	MBS-VR-002	WXD3-12	Potentiometer	1
86	HCR07	R55	C-Retainer Ring	2
86-1	272170		Bushing	1
87	HCS17	S30	C-Retainer Ring	1
88	CA6006LU	#6006-LU (TPI)	Bearing	2
89	272017		Gasket	1
90	272016A		Spindle Taper Sleeve	1
91	272065		Bearing Cap	1
92	HS519	M5x10L	Cross Round Head Screw	3
93	272018A		Spindle Pulley	1
94	7102B		Spindle Locknut	1
95	272107		Protective Plate	1
96	HS519	M5x10L	Cross Round Head Screw	2
97	6630		Washer	2
98	HS431	M8x16L	Hex. Socket Headless Screw	2
99	272053A		Motor Adjustment Base	1
100	HN006	M10	Hex. Nut	1
101	HS061	M10*35L	Hex. Head Screw	1
102	HW104	M6	Spring Washer	2
103	HS232	M6*30L	Hex. Socket Head Screw	2
104	SMMDV12509-3A	1.5HP/110V	DC Motor	1
104-1	M112084-4		DC Motor Carbon Brush	2
104-2	M112084-5		DC Motor Carbon Brush Cover	2
105	HK027	6*6*30L	Motor Shaft Key	1
106	272025A		Motor Plate	1
107	HW005	M8	Washer	4
108	HS046	M8x20L	Hex. Head Screw	4
109	HS430	M8x10L	Hex. Socket Headless Screw	2
110	272019A		Motor Pulley	1
111	HW005	8.5*18-1.6t	Washer	4
112	HS046	M8x20L	Hex. Head Screw	4
113	272046A	PJ290-10	Belt	1
114	MBS-AC1-002	100~115V//20A//RFI-DRI-01	Driver Board for 1.5HP	1
114-1	ME020111		Ground Wire	1
115	HS512	M4*25L	Cross Round Head Screw	4
116	272077		Cover	1
117	HS519	M5x10L	Cross Round Head Screw	4
118	MET2110	PG11	Cable-Gland	1
119	ME230331E		Power Cord	1

120	MET1249-1	110V	Switch	1
121	HS807	M4*15L	Self-Tapping Screws	4
122	272035A		Top Cover	1
123	PJNM403136E09		Label	2
124	HS521	M5*20L	Cross Round Head Screw	2
125	272078		Eye Bolt for lifting	1
126	PJNM403136E04		Label	1
127	6630		Washer	2
128	HS431	M8x16L	Hex. Socket Headless Screw	2
129	PJNM403136E08	CSA	Label	1
130	272096		RH Laser Cover	1
131	HS522	M5x25L	Cross Round Head Screw	1
132	PJNM403136E02	24*32.5*0.5	Right Laser Label	1
133	PJNM403136E05	60*34*0.2	Warning Label	1
134	272124S		RH Laser Assembly	1
134-1	MHCS13	S25	C-Retainer Ring	1
134-2	HO077	ø25.07xø30.31xd2.26	O-Retainer Ring	1
134-3	272124	Right	RH Laser Rack (Right)	1
134-4	272123	Right	RH Laser Rack Support (Right)	1
134-5	HS801	M3*6L	Self-Tapping Screws	2
134-6	272127		Press Plate	2
134-7	272126	650nm,10mW,5V, ø8*26MM/200mm	Laser Tube	1
134-8	272098		Laser Tube Sleeve	1
134-9	HS513	M4x30L	Cross Round Head Screw	1
134-10	HW002	M4	Washer	2
134-11	272120		Laser Base	1
134-12	272121		Hex. Socket Headless Screw	2
134-13	272128		Spring	1
134-14	HS513	M4x30L	Cross Round Head Screw	1
134-15	HW002	M4	Washer	2
134-16	272128		Spring	1
135	HS520	M5x15L	Cross Round Head Screw	2
136	272097		LH Laser Cover	1
137	HS522	M5x25L	Cross Round Head Screw	1
138	PJNM403136E01	24*32.5*0.5	Left Laser Label	1
139	PJNM403136E05	60*34*0.2	Warning Label	1
140	272122S	Left	RH Laser Assembly (Left)	1
140-1	MHCS13	S25 Axial	C-Retainer Ring	1
140-2	HO077	ø25.07xø30.31xd2.26	O-Retainer Ring	1
140-3	272122	Left	LH Laser Rack (Left)	1

140-4	272125	Left	LH Laser Rack support (Left)	1
140-5	HS801	M3*6L	Self-Tapping Screws	2
140-6	272127		Press Plate	2
140-7	272126	650nm,10mW,5V, ø8*26MM/200mm	Laser Tube	1
140-8	272098		Laser Tube sleeve	1
140-9	HS513	M4x30L	Cross Round Head Screw	1
140-10	HW002	M4	Washer	2
140-11	272120		Laser Base	1
140-12	272121		Hex. Socker Headless Screw	2
140-13	272128		Spring	1
140-14	HS513	M4x30L	Cross Round Head Screw	1
140-15	HW002	M4	Washer	2
140-16	272128		Spring	1
141	HS520	M5x15L	Cross Round Head Screw	2
142	272131		Handle Switch Base	1
143	HS520	M5X15L	Cross Round Head Screw	2
144	272132	§ 5*10L	Magnet	2
145	MET1610		Limit Switch	1
145-1	ME050201		Connection Cord	1
146	HS803	M3X15L	Self-Tapping Screws	2
147	PJNM403136E06	80*20mm	Small Warning Label	1
148	PJNM403136E03	131.7*129mm	Specification Label	1
149	272136A	CSA	Round Chuck Cover	1
200	272010A	TYPE=LA	Base	1
201	272008A	TYPE=LA	Column Base	1
202	MW204	M10	Spring Washer	4
203	HS262	M10x40L	Hex. Socket Head Screw	4
204	HS438	M10*10L	Hex. Socket Headless Screw	2
205	272112		Rack Collar	1
206	HS228	M6x10L	Hex. Socket Head Screw	2
207	6630		Washer	1
208	151174	M8*25L	Grip	1
209	272012		Column	1
210	272115		Rack	1
211	272112		Rack Collar	1
212	HS228	M6x10L	Hex. Socket Head Screw	2
213	6630		Washer	1
214	151174	M8*25L	Grip	1
215	S451	3/8"x4-1/2"L	Hex. Socket Head Screw	1
216	272084		Handle	1
217	N005	W3/8"-16UNC	Hex. Nut	1
218	6158A		Head Handle	1







219	S630	3/8"x1/2"L	Hex. Socket Headless Screw	
220	272081		Worm Shaft	1
221	260017		Worm Gear	1
222	272114		Worm Shaft	1
223	HW055	ϕ 12x ϕ 25x2T	Washer	1
224	272102	M12*50L	Grip	1
225	272111		Bracket Assembly	1
226	272113		Bushing	1
227	272109		Limit Plate	1
228	MHS502	M3X5L	Cross Round Head Screw	2
229	MHH001	ϕ 2x5L	Rivet	2
230	272117		Scale	1
231	272005		Working Table	1
232	272116		Table Insert	1
233	HN004	M6	Hex. Nut	4
234	HS231	M6x25L	Hex. Socket Head Screw	4
235	HW008	ϕ 12x ϕ 25x2T	Washer	1
236	272101	M12*70L	Grip	1
237	272118		Pin	1

#### INCLUDED ACCESSORIES

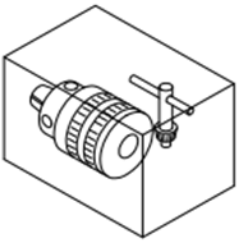
	MHE108	Hex. Wrench	3MM	1
	MHE101	Hex. Wrench	4MM	1
	MHE103	Hex. Wrench	5MM	1
	MHE109	Hex. Wrench	8MM	1
46	6168	Drift Key	MT2//JT3	1
47	272129	Drill Chuck	JT3 5/8"(3~16MM)	1
48	272100	Chuck Arbor	MT2//JT3	1
125	272078	Pole		1
138	PJNM403136E01	Laser Label (Right)	24*32.5MM	1
132	PJNM403136E02	Laser Label (Left)	24*32.5MM	1
148	PJNM403136E03	Speification Label	131.7*129MM	1
126	PJNM403136E04	QR Code Warning Label	100*137MM	1
133	PJNM403136E05	Yellow Caution Label	30*27MM	1
139	PJNM403136E05	Yellow Caution Label	30*27MM	1
147	PJNM403136E06	Small Wanning Label	80*20MM	1
129	PJNM403136E08	CSA ID Label	89*38MM	1
123	PJNM403136E09	LAGUNA Logo	367*53.8MM	2

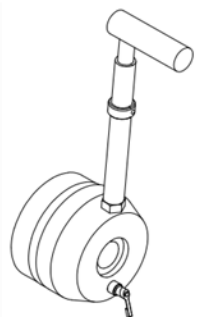
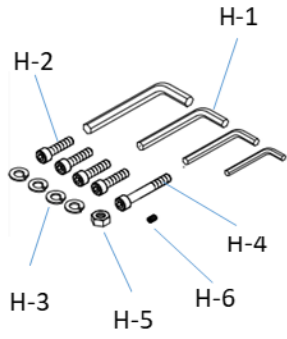

## Parts (loose) & Part numbers, quick reference

			
<b>A</b>	<b>B</b>	<b>C</b>	<b>D</b>
			
<b>E</b>	<b>F</b>	<b>G</b>	<b>H</b>

<u>Ref.</u>	<u>Description</u>	<u>Qty.</u>	<u>Part Number</u>
A	Drill Chuck With Key 5/8" (3-16mm)	1	M272129
B	Chuck Drift Key	1	M6168
C	Chuck Arbor (MT2/JT3)	1	M272100
D	Machine Lift Hook	1	M272078
E	Table Crank Lever	1	M6158A
F	Handle	1	M6027-2
G	Feed Handle And Hub	1	SM272022AS
H	Hardware Bag		
H-1	Allen Wrenches 3, 4, 5, 8mm	1 Ea.	MHE108/101/103/110
H-2	Hex Socket Head Screw (M10xM40 L)	4	HS262
H-3	Spring Washer (M10)	4	HW106
H-4	Hex. Socket Head Screw (3/8"x4-1/2"L)	1	MS451
H-5	Hex. Nut (W3/8"-16UNC)	1	MN005

If you cannot find an item on this list, carefully check around/inside the machine and packaging materials.

## Accessories

Accessories are available for the DP20. A listing of all accessories can be found at our website, **lagunatools.com**

Several optional lights are available. They can be affixed to either the left or right side of the headstock. These lights can complement the included, central headstock light, by illuminating projects and drilling when the stock has a unique shape (creating shadows) or if the table is tilted and/or pivoted from the center position. Some of the lights can be attached directly to the DP20, using the four pre-drilled and tapped holes on each side of the headstock or attached using a magnetic base.

Several of the lights are listed below, but a complete listing can be found on our website by following the, below, URL:

<https://www.shop.lagunatools.com/classic-machinery/machine-lamps-lights/laguna-led-lights>

LED light, Part # **ALEDMACH**

LED light, Part # **ALEDSPINE**

LED light, Part # **ALEDLATHE**

## Laguna Tools

744 Refuge Way, Suite 200  
Grand Prairie TX 75050

800-234-1976

[www.lagunatools.com](http://www.lagunatools.com)

# LAGUNA

[www.lagunatools.com](http://www.lagunatools.com)