

# CIFLUX:1



1.5HP CYCLONE  
1 MICRON CANISTER



# LAGUNA



Thank you for investing in a Laguna Tools CFLUX1 cyclone dust collector. This cyclone is one of a family of unique machines proudly offered by Laguna Tools. Every Laguna machine is engineered for years of dependable service. Please feel free to contact Laguna Tools if you have a question or suggestion. We appreciate working with you and your choice of a Laguna Tools machine for your shop.

Regards,  
Torben Helshoj  
President & Founder Laguna Tools

### Dealer Machinery Warranty

New woodworking machines sold by Laguna Tools carry a two-year warranty effective from the date of dealer invoice to consumer. Machines sold through dealers must be registered with Laguna Tools within 30 days of purchase to be covered by this warranty. Laguna Tools guarantees all new machine sold to be free of manufacturers' defective workmanship, parts and materials. We will repair or replace, without charge, any parts determined by Laguna Tools, Inc. to be a manufacturer's defect. We require that the defective item/part be returned to Laguna Tools with the complaint. An RMA (return merchandise authorization) must be requested, from Laguna Tools, and included with any and all parts or machines returned to Laguna Tools for warranty consideration. Any machines returned to Laguna Tools must be returned with packaging in the same manner in which it was received. If a part or blade is being returned it must have adequate packaging to ensure no damage is received during shipping. In the event the item/part is determined to be damaged due to lack of maintenance, cleaning or misuse/abuse, the customer will be responsible for the cost to replace the item/part, plus all related shipping charges. This limited warranty does not apply to natural disasters, acts of terrorism, normal wear and tear, product failure due to lack of maintenance or cleaning, damage caused by accident, neglect, lack of or inadequate dust collection, misuse/abuse or damage caused where repair or alterations have been made or attempted by others.

This manual applies to the CFLUX 1 cyclone dust collector. Enter the model number and serial number below for quick reference when ordering accessories, supplies or parts. NOTE: The model and serial number plate can be found on the Top Upright Support, on the right side near filter and On/Off switch, see Fig. 38.

Model: \_\_\_\_\_

Revision: R01 V01 03/12/2025

Serial: \_\_\_\_\_

Laguna Tools

744 Refuge Way Suite 200

Grand Prairie TX 75050

800-234-1976

[www.lagunatools.com](http://www.lagunatools.com)



## CONTENTS

Warranty:	01
Safety:	03
Important Safety Instructions	04
General Safety Rules	08
Wiring Diagrams:	10
Power Connections	10
Unpacking:	15
Assembly:	16
Power Supply	32
Connecting to 220 Volt, single phase	32
Programming Remote Control	34
Operation:	34
Maintenance:	35
Trouble Shooting:	39
Parts Breakdown / Exploded Views:	41
Parts List	46
Specifications:	50
Supplies:	50

# LAGUNA

---

## SAFETY

READ AND UNDERSTAND THIS MANUAL AND ALL INSTRUCTIONS BEFORE USING THIS EQUIPMENT. Failure to follow all instructions may result in electric shock, fire and/or serious personal injury or property damage! Electronic copies of this manual are available at [www.lagunatools.com](http://www.lagunatools.com).

### SAFETY GUIDELINES - DEFINITIONS

This manual contains information that is important for you to know and understand. This information relates to protecting YOUR SAFETY and PREVENTING EQUIPMENT PROBLEMS. To help you recognize this information, we use the symbols below. Please read the manual and pay attention to these sections.



Indicates an imminently hazardous situation which, if not avoided, **will** result in death or serious injury.



Indicates a potentially hazardous situation which, if not avoided, **could** result in death or serious injury.



Indicates a potentially hazardous situation which, if not avoided, **may** result in minor or moderate injury.

**CAUTION**

(Used without the safety alert symbol) indicates a potentially hazardous situation which, if not avoided, **may** result in property damage.

# LAGUNA

Woodworking (and similar materials) can be dangerous if safe and proper operating procedures are not followed. As with all machinery, there are certain hazards involved with the operation of the machine. Using the machine with respect and caution will considerably lessen the possibility of personal injury. However, if normal safety precautions are overlooked or ignored, personal injury to the operator may result. Safety equipment such as guards, push sticks, hold-downs, featherboards, goggles, dust masks and hearing protection can reduce the potential for injury. Even the best guard will not make up for poor judgement, carelessness or inattention. **Always use common sense** and exercise caution in the workshop. If a procedure feels dangerous, do not try it. Figure out an alternative procedure that is safer. **REMEMBER:** Your personal safety is your responsibility.

## IMPORTANT SAFETY INSTRUCTIONS

### **WARNING**

This machine was designed for certain applications only. We strongly recommend that this machine not be modified and/or used for any application other than that for which it was designed. If you have any questions relative to a particular application, DO NOT use the machine until you have first contacted the manufacturer to determine if it can or should be performed on the product.

If you have any questions relative to its application DO NOT use the product until you have contacted the manufacturer and we have advised you.

When using an electrical appliance/machine, basic precautions should always be followed, including the following:

READ ALL INSTRUCTIONS BEFORE USING (THIS APPLIANCE/MACHINE)

### **WARNING**

To reduce the risk of fire, electric shock, or injury:

1. Do not leave appliance when plugged in. Unplug from outlet when not in use and before servicing.
2. Do not use outdoors or on wet surfaces
3. Do not allow to be used as a toy. Close attention is necessary when used by or near children.
4. Use only as described in this manual. Use only manufacturer's recommended attachments.
5. Do not use with damaged cord or plug. If appliance is not working as it should, has been dropped, damaged, left outdoors, or dropped into water, return it to a service center.



6. Do not pull or carry by cord, use cord as a handle, close a door on cord, or pull cord around sharp edges or corners. Do not run appliance over cord. Keep cord away from heated surfaces.
7. Do not unplug by pulling on cord. To unplug, grasp the plug, not the cord.
8. Do not handle plug or appliance with wet hands.
9. Do not put any object into openings. Do not use with any opening blocked; keep free of dust, lint, hair, and anything that may reduce air flow.
10. Keep hair, loose clothing, fingers, and all parts of body away from openings and moving parts.
11. Turn off all controls before unplugging.
12. Use extra care when cleaning on stairs.
13. Do not use to pick up flammable or combustible liquids, such as gasoline, or use in areas where they may be present.
14. Connect to a properly grounded outlet only. See Grounding Instructions.

### **SAVE THESE INSTRUCTIONS**

1. Read and understand the warnings posted on the machine and in this manual. Failure to comply with all of these warnings may cause serious injury.
2. Replace the warning labels if they become obscured or removed.
3. This 1.5HP Portable Cyclone Dust Collector is designed and intended for use by properly trained and experienced personnel only. If you are not familiar with the proper and safe operation of this type of dust collector, do not use until proper training and knowledge have been obtained.
4. Do not use this machine for other than its intended use. If used for other purposes, **LAGUNA TOOLS INC.**, disclaims any real or implied warranty and holds itself harmless from any injury that may result from that use.
5. Always wear approved safety glasses/face shields while using this machine.
6. Before operating this dust collector, remove tie, rings, watches and other jewelry, and roll sleeves up past the elbows. Remove all loose clothing and confine long hair. Non-slip footwear or anti-skid floor strips are recommended. Do **not** wear gloves.
7. Wear ear protectors (plugs or muffs) during extended periods of operation.
8. Some dust created by power sanding, sawing, grinding, drilling and other construction activities contain chemicals known to cause cancer, birth defects or other reproductive harm. Some examples of these chemicals are: (next page)

# LAGUNA

- Lead from lead based paint.
- Crystalline silica from bricks, cement and other masonry products.
- Arsenic and chromium from chemically treated lumber.

Your risk of exposure varies, depending on how often you do this type of work. To reduce your exposure to these chemicals, work in a well-ventilated area and work with approved safety equipment, such as face or dust masks that are specifically designed to filter out microscopic particles.

9. Do not operate this machine while tired or under the influence of drugs, alcohol or any medication.
10. Make certain the switch is in the **OFF** position before connecting the machine to the power source.
11. Make certain the machine is properly grounded.
12. Make all machine adjustments or maintenance with the machine unplugged from the power source.
13. Form a habit of checking to see that all extra equipment such as adjusting keys, wrenches, scrap, stock, and cleaning rags are removed away from the machine before turning on.
14. Keep safety guards in place at all times when the machine is in use. If removed for maintenance purposes, use extreme caution and replace the guards immediately when maintenance is complete.
15. Make sure the dust collector is on a flat even surface and the wheels locked in place before use.
16. Check damaged parts. Before further use of the machine, a guard or other part that is damaged should be carefully checked to determine that it will operate properly and perform its intended function. Check for alignment of moving parts, binding of moving parts, breakage of parts, mounting and any other conditions that may affect its operation. A guard or other part that is damaged should be properly repaired or replaced.
17. Provide for adequate space surrounding work area and non-glare, overhead lighting.
18. Keep the floor around the machine clean and free of scrap material, oil and grease.
19. Keep visitors a safe distance from the work area. **Keep children away.**



20. Make your workshop child proof with padlocks, master switches or by removing starter keys.
21. Give your work undivided attention. Looking around, carrying on a conversation and “horse-play” are careless acts that can result in serious injury.
22. Maintain a balanced stance at all times so that you do not fall or lean against the dust collector. Do not overreach or use excessive force to perform any machine operation.
23. Use the right tool at the correct speed and feed rate. Do not force a tool or attachment to do a job for which it was not designed. The right tool will do the job better and safer.
24. Use recommended accessories; improper accessories may be hazardous.
25. Maintain machinery with care. Follow instructions for lubricating and changing accessories.
26. Turn off the machine before cleaning. Use a brush or compressed air to remove dust or debris — do not use your hands.
27. Do not stand on the machine. Serious injury could occur if the machine tips over.
28. Never leave the machine running unattended. Turn the power off and do not leave the machine until it comes to a complete stop.
29. Never operate or run the machine without closing the drum up against the lid. Failure to do so will result in the machine amperage increasing and may trip your circuit.

Familiarize yourself with the following safety notices used in this manual:

## **SAFETY GUIDELINES - DEFINITIONS**

This manual contains information that is important for you to know and understand. This information relates to protecting YOUR SAFETY and PREVENTING EQUIPMENT PROBLEMS. To help you recognize this information, we use the symbols, described earlier. Please read the manual and pay attention to these sections.



## GENERAL SAFETY RULES



**FAILURE TO FOLLOW THESE RULES MAY RESULT IN SERIOUS INJURY.**

**FOR YOUR OWN SAFETY, READ AND UNDERSTAND THE INSTRUCTION MANUAL BEFORE OPERATING THE MACHINE.** Learn the unit's application and limitations as well as the specific hazards peculiar to it.

**KEEP WORK AREA CLEAN.** Cluttered areas and benches invite accidents.

**DON'T USE IN DANGEROUS ENVIRONMENT.** Don't use this unit in damp or wet locations, or expose it to rain. Keep work area well-lighted.

**KEEP CHILDREN AND VISITORS AWAY.** All children and visitors should be kept a safe distance from work area.

**DISCONNECT UNIT** before servicing.

**CHECK DAMAGED PARTS.** Before further use of the unit, properly repair or replace any part that is damaged.



**FAILURE TO FOLLOW THESE RULES MAY RESULT IN SERIOUS INJURY.**

## ADDITIONAL SAFETY FOR DUST COLLECTORS

**Intended use.** This dust collector is only intended for collecting wood dust and chips from woodworking machines. Do not use this dust collector to collect metal, dirt, pebbles, drywall, asbestos, lead paint, silica, liquids, aerosols, or any flammable, combustible, or hazardous materials.

**Hazardous dust.** Dust created while using machinery may cause cancer, birth defects, or long-term respiratory damage. Be aware of dust hazards associated with each work piece material, and always wear a NIOSH-approved respirator to reduce your risk.

**Dust allergies.** Dust from certain woods may cause an allergic reaction in people and animals.

Make sure you know what type of wood dust you will be exposed to in case there is a possibility of an allergic reaction.

# LAGUNA

**Wear respirator.** Fine dust that is too small to be caught in the filter will be blown into the ambient air during operation. Always wear a NIOSH-approved respirator during operation and for a short time after to reduce your risk of permanent respiratory damage.

**Emptying dust.** When emptying dust from the collection container, wear a respirator and safety glasses. Empty dust away from ignition sources and into an approved container.

**Disconnecting power supply.** Turn the switch off, disconnect the dust collector from the power supply, and allow the impeller to come to a complete stop before leaving the machine unattended or doing any service, cleaning, maintenance, or adjustments.

**Suspended dust particles and ignition sources.** Do not operate the dust collector in areas where explosion risks are high. Areas of high risk include, but are not limited to, areas near pilot lights, open flames, or other ignition sources.

**Fire suppression.** Only operate the dust collector in locations that contain a fire suppression system or have a fire extinguisher nearby.

**Impeller hazards.** Do not place your hands or tools near the open inlet during operation for any reason. The powerful suction could easily cause accidental contact with the impeller, which will cause serious personal injury or damage to the machine. Always keep small animals and children away from open dust collection inlets.

**Avoiding sparks.** Do not allow steel or rocks to strike the impeller—this may produce sparks. Sparks can smolder in wood dust for a long time before a fire is detected. If you accidentally cut into wood containing tramp metal (nails, staples, spikes, etc.), immediately turn **off** the dust collector, disconnect it from power, and wait for the impeller to stop—then empty the collection container into an approved airtight metal container.

**Operating location.** To reduce respiratory exposure to fine dust, locate permanently installed dust collectors away from the working area, or in another room that is equipped with a smoke detector. Do not operate the dust collector in rainy or wet locations—exposure to water may create a shock hazard or decrease the life of the machine.

**Static electricity.** Plastic dust lines generate high amounts of static electricity as dust chips pass through them. Although rare, sparks caused by static electricity can cause explosions or fire. To reduce this risk, make sure all dust lines are thoroughly grounded by using a grounding wire.

**Regular cleaning.** Regularly check/empty the collection bags or drum to avoid the buildup of fine dust that can increase the risk of fire. Make sure to regularly clean the surrounding area where the machine is operated—excessive dust buildup on overhead lights, heaters, electrical panels, or other heat sources will increase the risk of fire.

SAVE THESE INSTRUCTIONS.  
Refer to them often and use them to instruct others.

## WIRING DIAGRAMS

### POWER CONNECTIONS

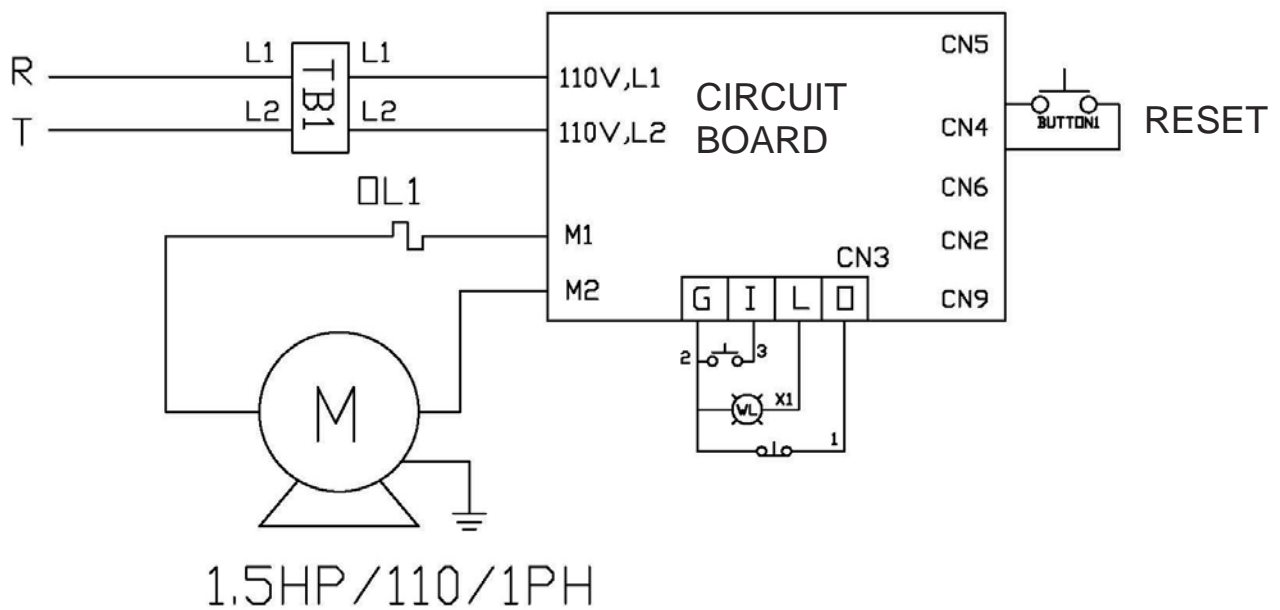


Figure 1: Power Connections & Wiring

# LAGUNA

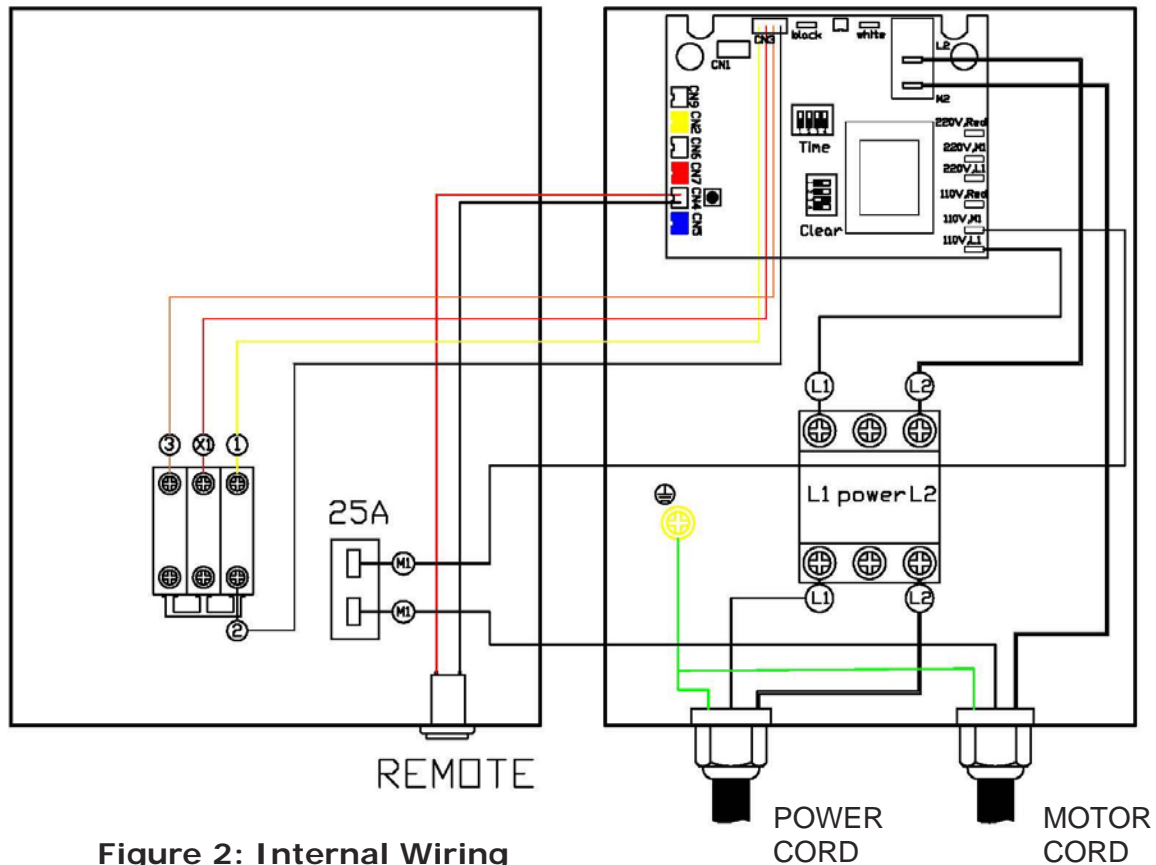


Figure 2: Internal Wiring

## DANGER

DO NOT EXPOSE THE MACHINE TO RAIN OR OPERATE THE MACHINE IN DAMP LOCATIONS.

### MOTOR SPECIFICATIONS

Your machine is wired for 110 volts, 60 HZ alternating current. Before connecting the machine to the power source, make sure the switch is in the "OFF" position. An (appx.) 8' cord is included, a "plug" is NOT included. A plug must be installed by a qualified technician.

### GROUNDING INSTRUCTIONS

## DANGER

THIS MACHINE MUST BE GROUNDED WHILE IN USE TO PROTECT THE OPERATOR FROM ELECTRIC SHOCK.

# LAGUNA

1. This appliance must be connected to a grounded metal, permanent wiring system; or an equipment-grounding conductor must be run with the circuit conductors and connected to the equipment-grounding terminal or lead on the appliance.

The installer, such as a qualified electrician, cut (or bend over) and insulate the grounding conductor from a field wiring supply cable.

In the event of certain types of malfunctions or breakdowns, grounding provides a path of least resistance for electric current—in order to reduce the risk of electric shock.

Improper connection of the equipment-grounding wire can result in a risk of electric shock. The wire with green insulation (with or without yellow stripes) is the equipment-grounding wire. If repair or replacement of the power cord or plug is necessary, do not connect the equipment-grounding wire to a live (current carrying) terminal.

Check with a qualified electrician or service personnel if you do not understand these grounding requirements, or if you are in doubt about whether the tool is properly grounded. If you ever notice that a cord or plug is damaged or worn, disconnect it from power, and immediately replace it with a new one.

## Full Load amperage Draw

Amp draw at 110V (prewired)..... 18.8 Amps  
Amp draw at 220V ..... 9.4 Amps

## Power Supply Circuit Requirements

The power source circuit for your machine must be grounded and rated for the amperage given below. Never replace a circuit breaker on an existing circuit with one of higher amperage without consulting a qualified electrician to ensure compliance with wiring codes. **If you are unsure about the wiring codes in your area or you plan to connect your machine to a shared circuit, consult a qualified electrician.**

Circuit Size (220V).....15 Amp minimum  
Circuit Size (110V) .....30 Amp minimum



IN ALL CASES, MAKE CERTAIN THE RECEPTACLE IN QUESTION IS PROPERLY GROUNDED. IF YOU ARE NOT SURE, HAVE A QUALIFIED ELECTRICIAN CHECK THE RECEPTACLE.

## 110 VOLT Single-Phase Operation

The motor supplied with your machine is a dual voltage, 110/220 Volt motor. It is shipped ready-to-run for 110 **Figure** Volt operation. However, it can be converted for 220 Volt operation. An (appx.) 8' cord is included, a "plug" is NOT included. A plug must be installed by a qualified technician.

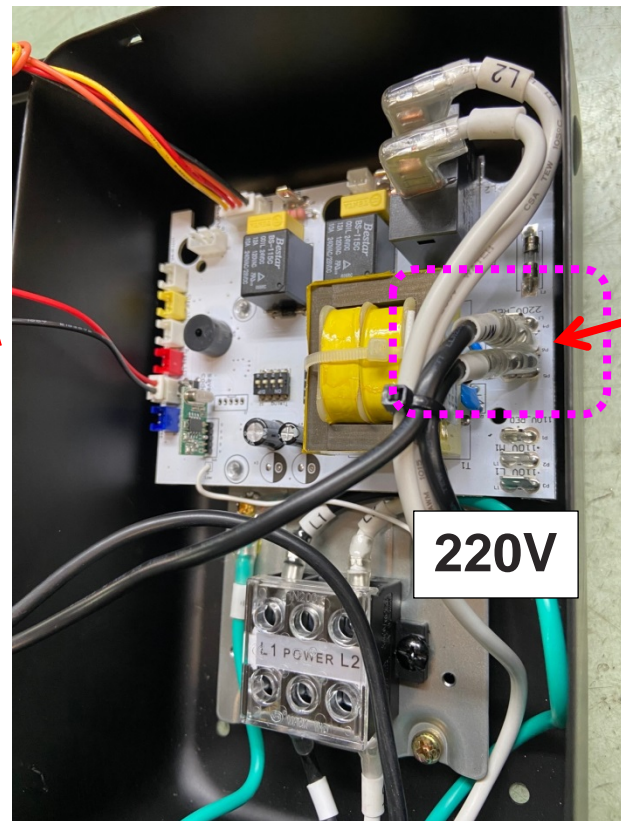
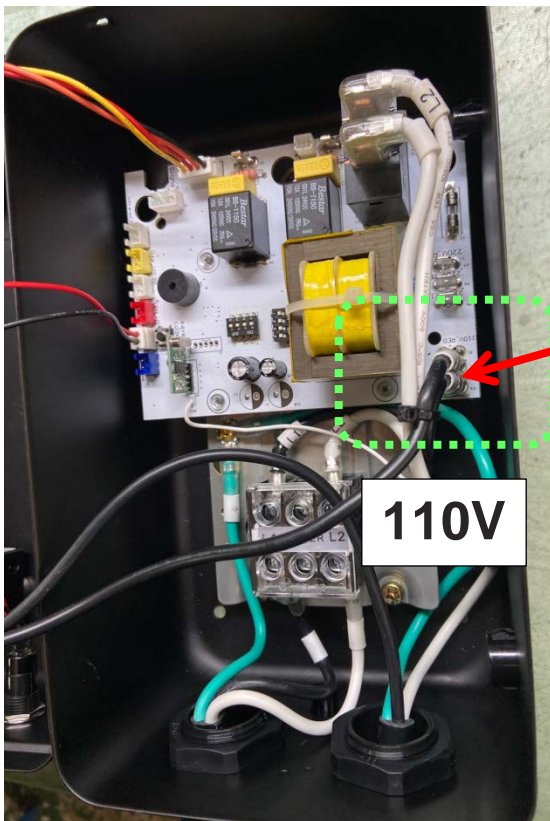
# LAGUNA

A qualified electrician should do the conversion, or the machine can be taken to an Authorized Dealer Service Center. When completed, the machine must conform to the National Electric Code and all local codes and ordinances.

The voltage conversion procedure consists of rewiring the motor, rewiring the circuit board to 220V, and replacing the overload protector. The overload protector (part # PDCCF15110-220-OV) can be purchased by contacting Laguna Tools Customer Service by calling (800) 332-4094 or via email: [customer\\_service@lagunatools.com](mailto:customer_service@lagunatools.com)

## Converting to 220V:

1. Before removing any parts, turn OFF the machine and remove the power source.
2. Open the switch to reach inside by removing the screw located at the bottom of the switch cover.
3. Reach inside to the control box and remove the connectors shown below on the 110V photo. Connect these two connectors to the 220V pins as shown below on the 220V photo.

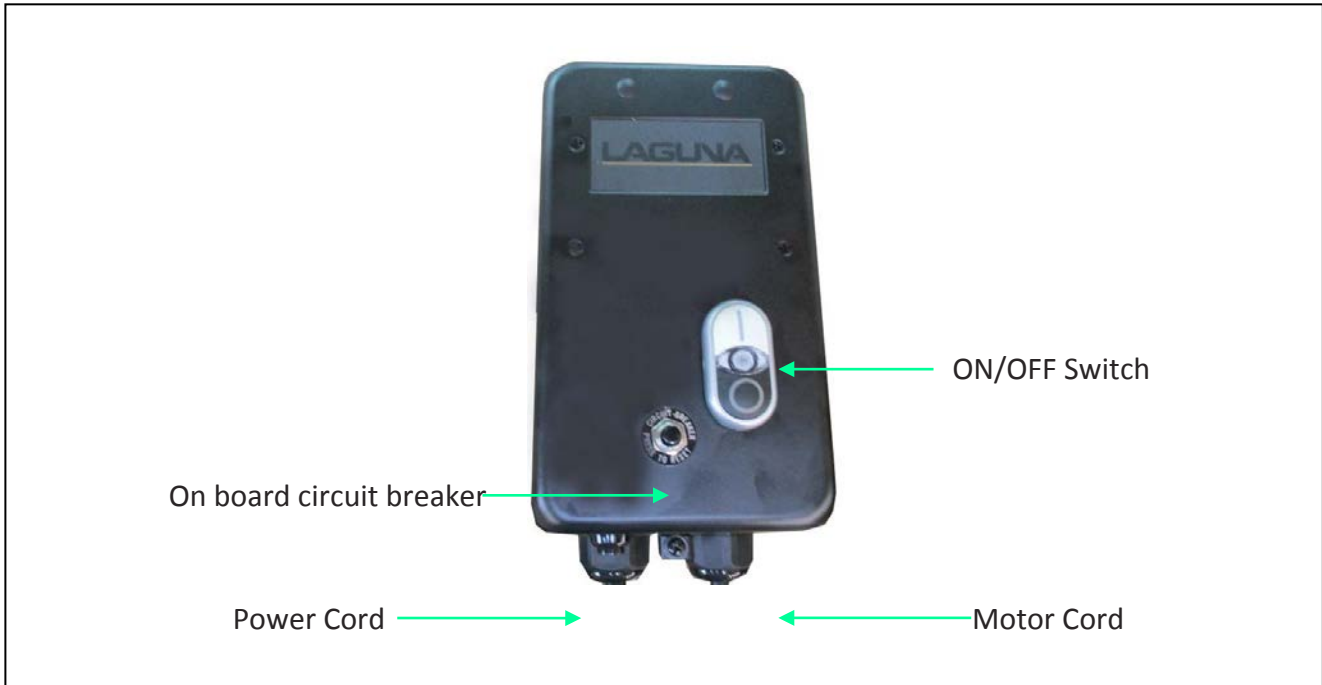




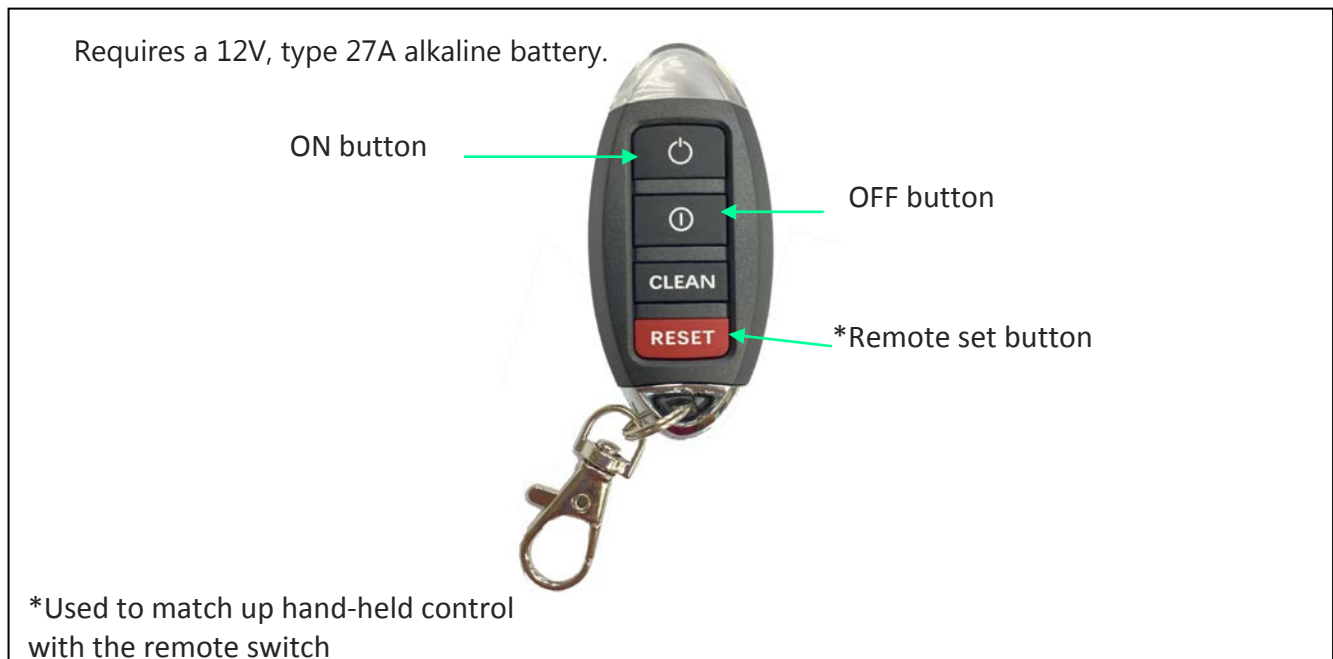


# LAGUNA

## FUNCTION



**Figure 3: High Frequency Remote Control Receiver and Manual Switch**



**Figure 4: Hand-Held Remote Control**

# LAGUNA

## PROGRAMMING THE REMOTE CONTROL

Programming should be completed after machine assembly. See pages 34 & 35.

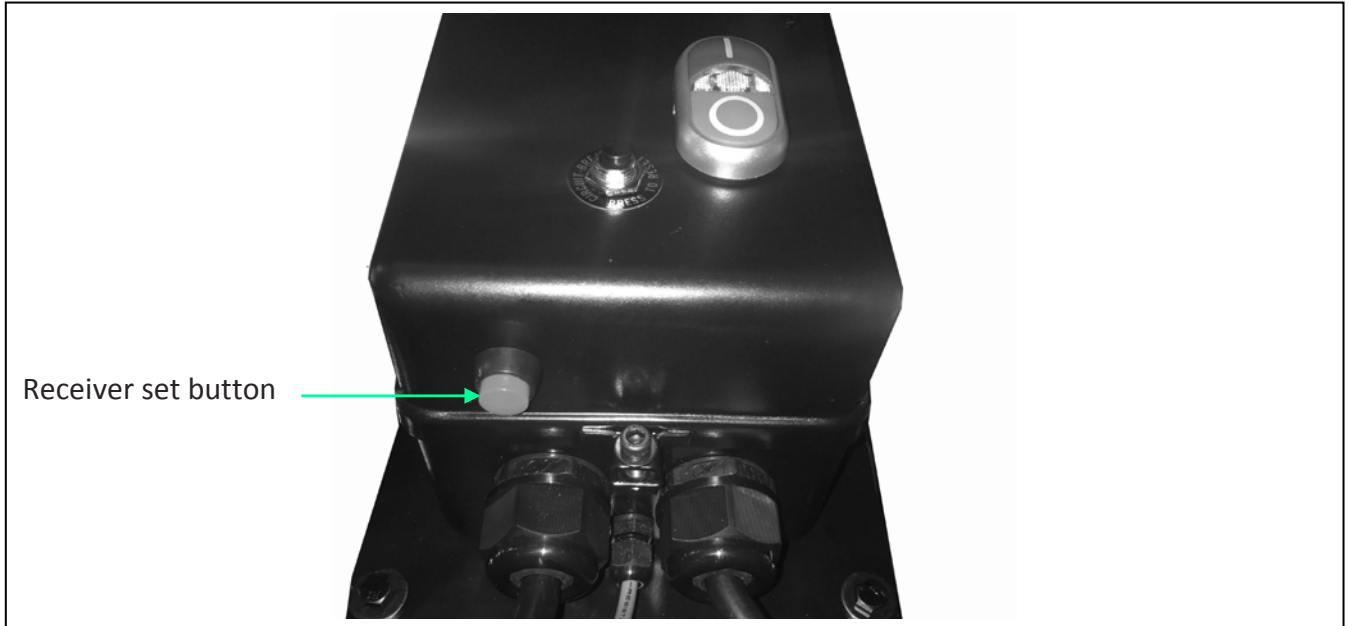


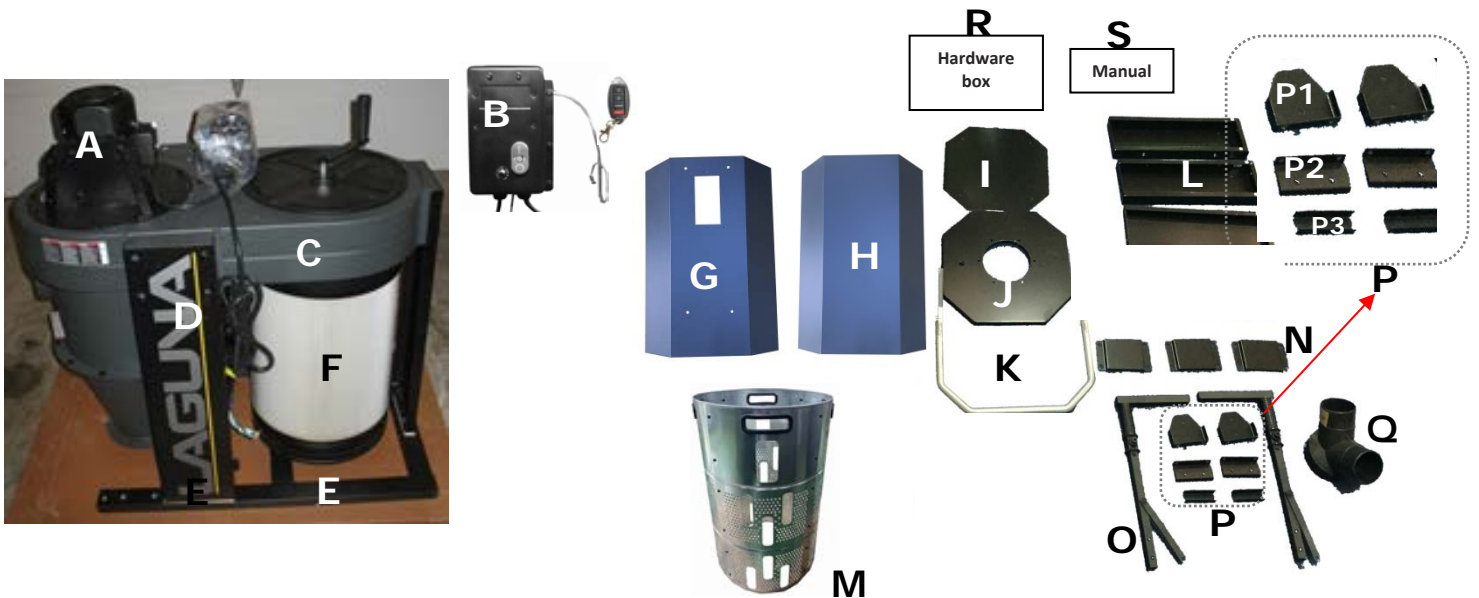
Figure 5: Receiver Set Button

# LAGUNA

## UNPACKING

Your 1.5HP Mobile Dust Cyclone comes packed in a single box. Before attempting to assemble this machine, follow these directions for unpacking:

1. Carefully cut the banding straps and remove them from the box.
2. Cut along the tape line at the top of the box.
3. Remove all parts from the top of the foam and set aside. Page 16
4. Remove the foam packing material from the top of the machine and **set aside for further use, during assembly.**
5. Cut the cardboard box (top to bottom) in the four corners for easy removal of the box.
6. Carefully take out the machine components from the box and set aside.
7. Using the diagram below, ensure that all parts are present and in good condition.



**Figure 6: Components/Inventory**

### DESCRIPTION (QUANTITY)

- |                               |  |
|-------------------------------|--|
| A. Motor                      | M. Drum insert                             |
| B. Switch and remote control  | N. Upright support reinforcement plate (3) |
| C. Dust chute                 | O. Foot pedal bar (left & right)           |
| D. Top upright supports (3)   | P. Foot pedal assembly fittings            |
| E. Base frame                 | P1. Lower triangular support plate (2)     |
| F. Canister filter            | P2. Foot pedal bar support (2)             |
| G. Octagon drum front panel   | P3. Lower support plate (2)                |
| H. Octagon drum back panel    | Q. Inlet adapter                           |
| I. Octagon drum base panel    | R. Hardware box (Casters, hardware)        |
| J. Octagon drum lid           | S. Operating and Parts Manual              |
| K. Octagon drum foot pedal    |  |
| L. Lower upright supports (3) |  |

# LAGUNA

Report any missing or damaged parts to your dealer or distributor. Prior to tool assembly and use, read this manual thoroughly to familiarize yourself with proper assembly, maintenance and safety procedures. NOTE: YouTube assembly video available; [CFlux Cyclone Dust Collection Setup | Laguna Tools](#)

## ASSEMBLY

### WARNING

**This step requires two adults.** This 1.5 HP Mobile Dust Cyclone is heavy, be careful when lifting and handling it! Failure to comply may cause serious injury and/or damage to the machine and/or property!

#### **Tools/items Required:**

10mm wrench / 12mm wrench / 14mm wrench  
Phillips screwdriver  
4mm hex wrench / 5mm hex wrench  
Plug for cord, 3 wire

To assemble your dust cyclone, follow these steps:

For your own safety, do not connect the machine to the power source until the machine is completely assembled. Please also make sure that you read and understand the entire instruction manual.

**ASSEMBLY TIME ESTIMATE** 4 to 5 hours

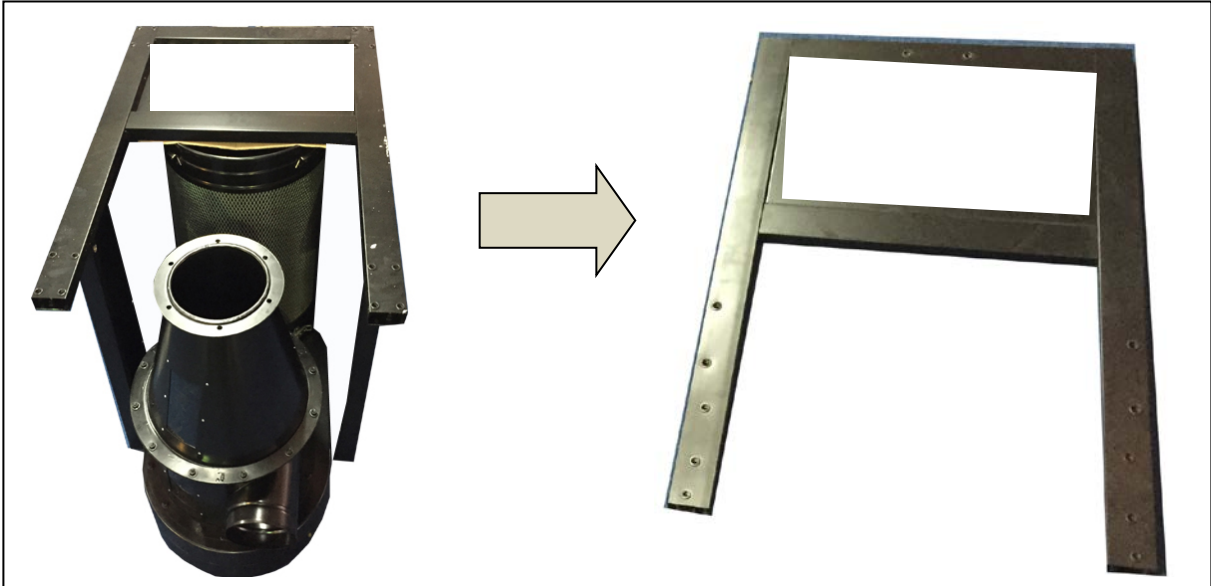
1. Place the empty, top, foam packing insert (which contained the individual parts) upside-down on the floor. Place the main unit into the styrofoam insert upside-down (Fig. 7). Make sure the unit is centered properly and resting solidly in the foam insert for the next steps.



**Figure 7: Placing the main component for assembly upside-down**

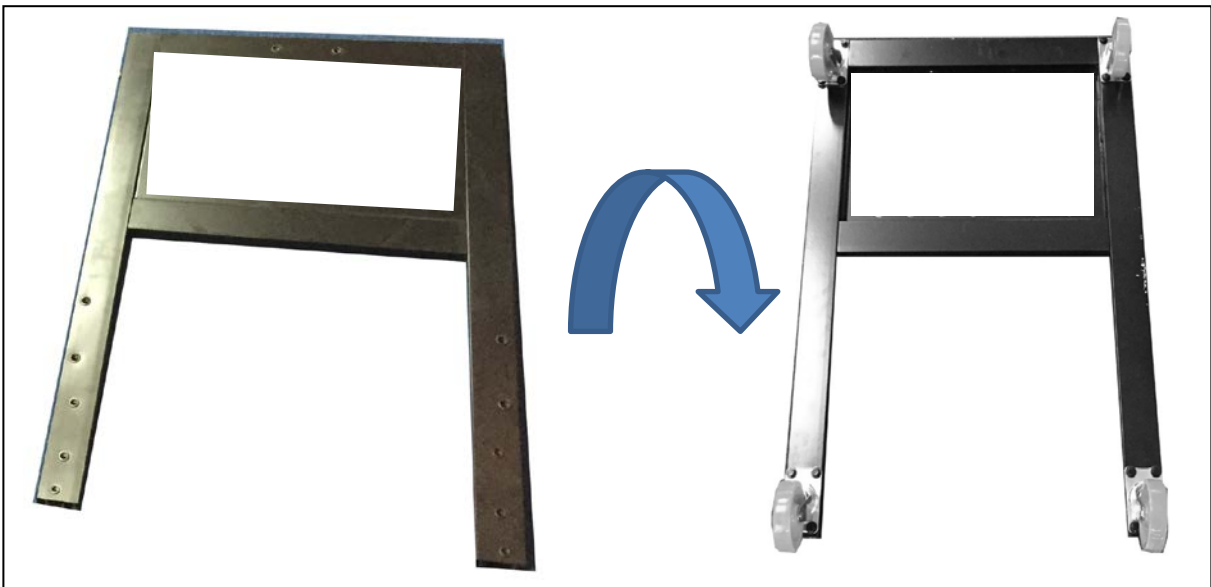
# LAGUNA

2. Remove the base which has been bolted to the (3) top upright supports, Fig. 8).



**Figure 8: Removing base**

3. Turn base upside-down and attach the (4) 3" casters to the underside of the base using (16) 5/16" x 3/4" hex bolts and (16) 5/16" x 18 flat washers.



**Figure 9: Attaching casters**

# LAGUNA

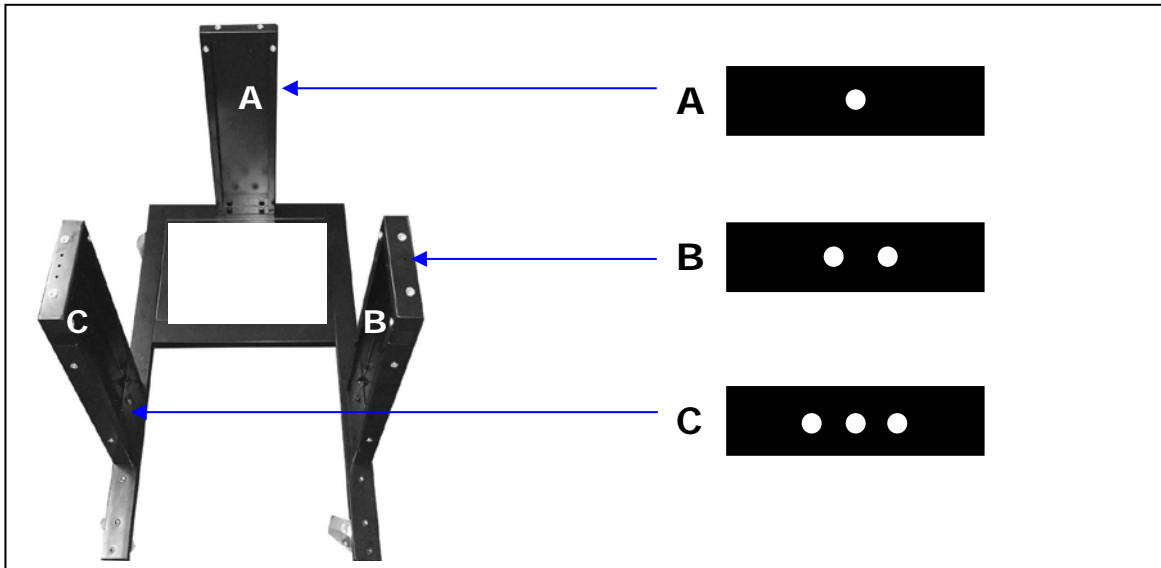
4. Turn the base over with it standing on the (4) 4" casters and secure the three lower upright support panels using (6) 3/8" x 3/4" hex bolts and (6) 3/8" x 7/8" flat washers.

Each lower upright support panel is identified for its specific location.

A – shown with one dot is located on the canister side.

B – shown with two dots is located on the front side

C – shown with three dots is located on the opposite end.



**Figure 10: Attaching support panels to base**

5. Secure the base with (3) lower upright support panels to the unit using (6) 5/16" x 3/4" hex bolts and (6) 5/16" x 1" flat washers.



**Figure 11: Securing base with support panels**

# LAGUNA

6. Secure the (3) upright support reinforcement plates using (12) 5/16" x 3/4" hex bolts and (12) 5/16" x 1" flat washers.

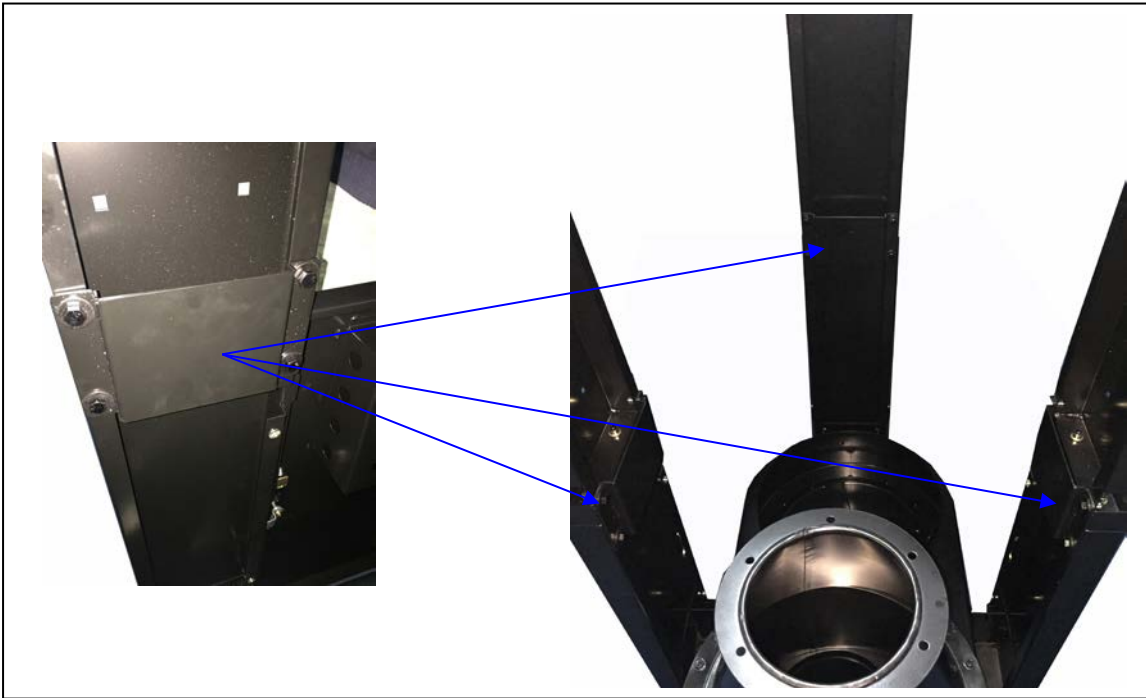


Figure 12: Securing plates

7. ***With the help of another person***, lift the unit up carefully and rotate to the *right-side-up* with the motor on top and the wheels at the bottom.

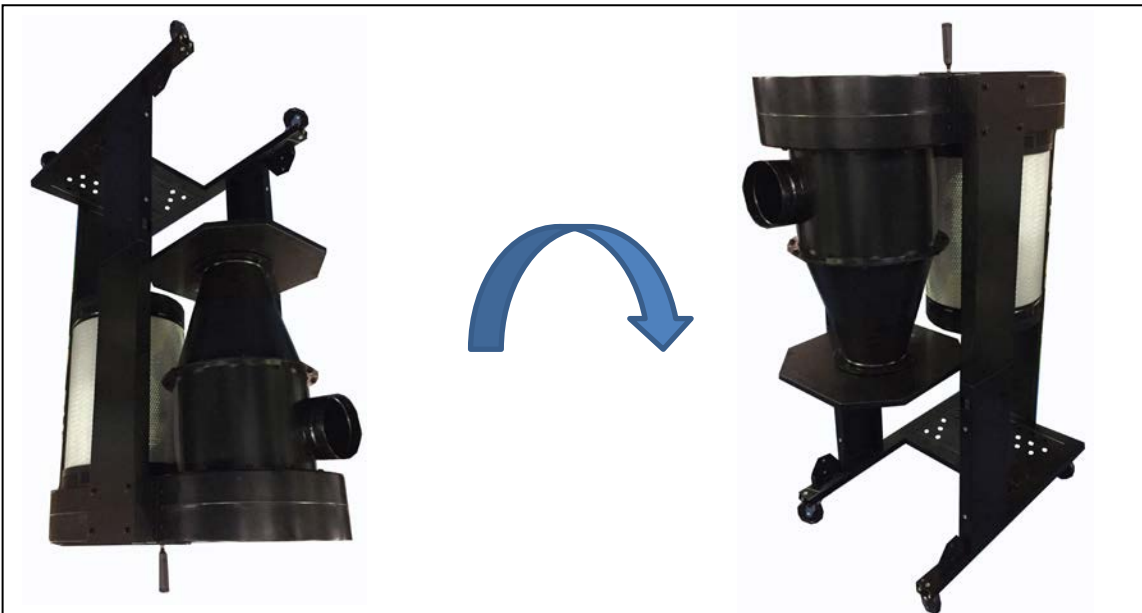
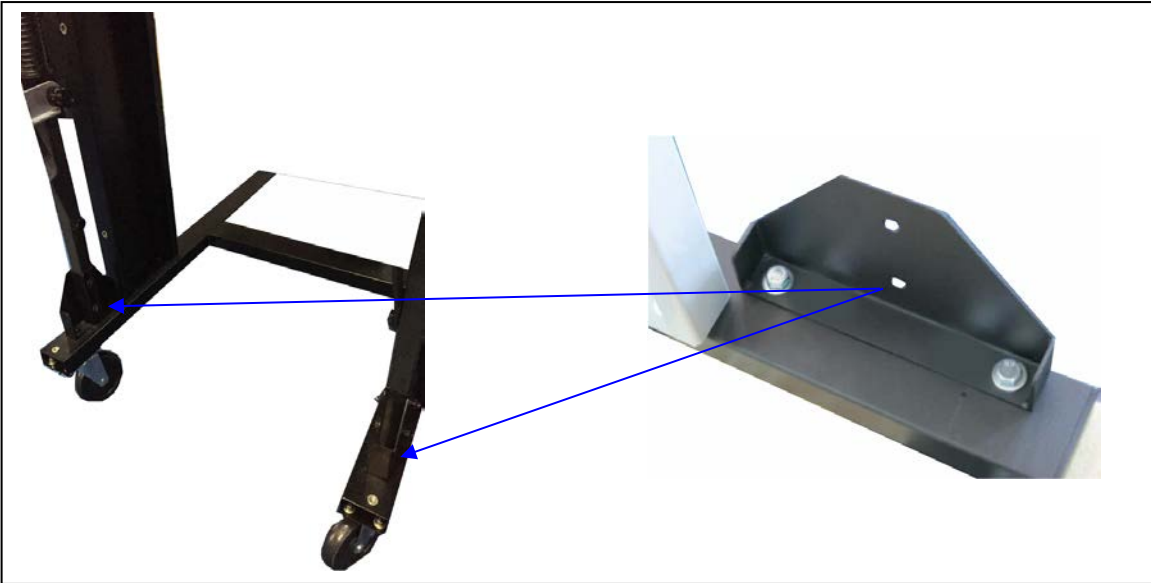


Figure 13: Standing machine *right-side-up*

# LAGUNA

8. Secure the lower triangular support plate to the base using (2) 5/16" x 3/4" hex bolts and (2) 5/16" x 1" flat washers. Follow the same steps for the opposite side.



**Figure 14: Securing lower triangular support plate**

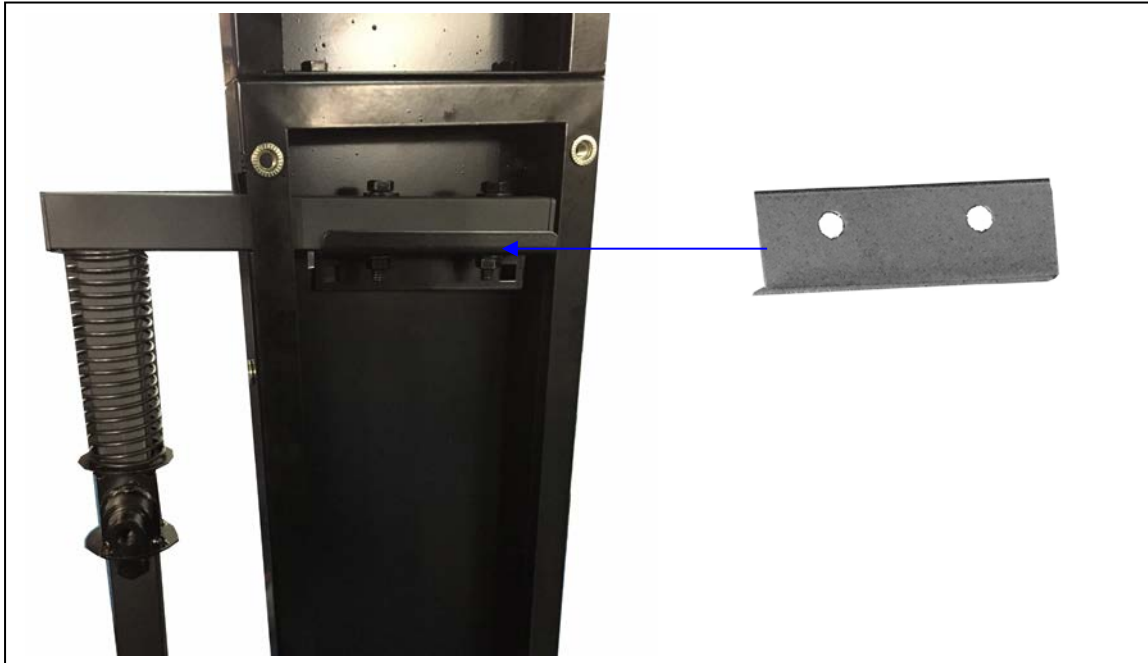
9. Slide the Foot pedal bar into the opening on the lower upright support panel. Make sure the end of the bar is on the inside of the triangular support plate. Follow the same steps for the opposite side.



**Figure 15: Securing foot pedal bar**

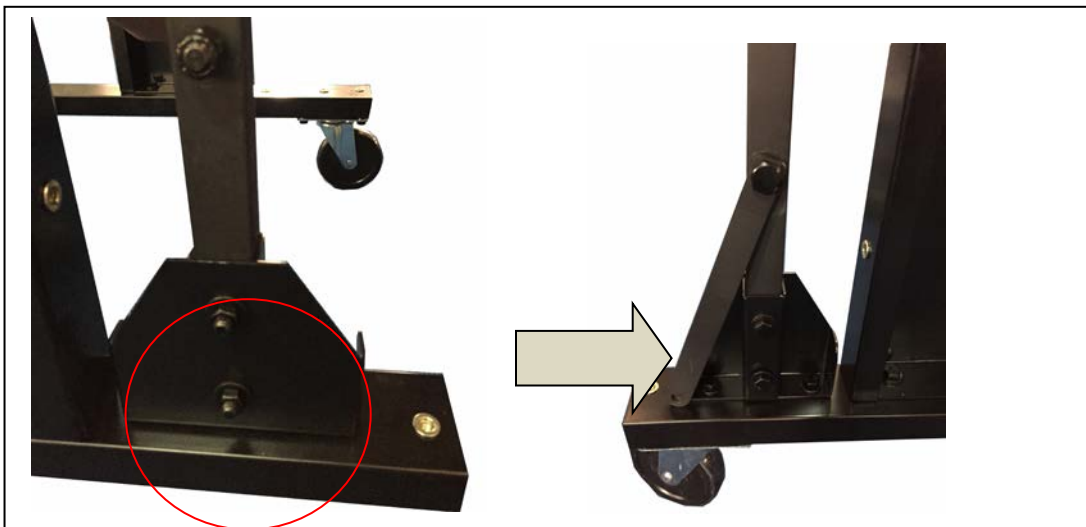
# LAGUNA

10. Secure the foot pedal support to the lower upright support panel using (4) 5/16" x 1/2" carriage bolts, (8) 5/16" x 1" flat washers and (4) 5/16" hex nuts. Next secure the foot pedal bar to this support using (4) 5/16" x 1-3/4" hex bolts, (8) 5/16" x 1" flat washers and (4) 5/16" hex nuts. Follow the same steps for the opposite side.



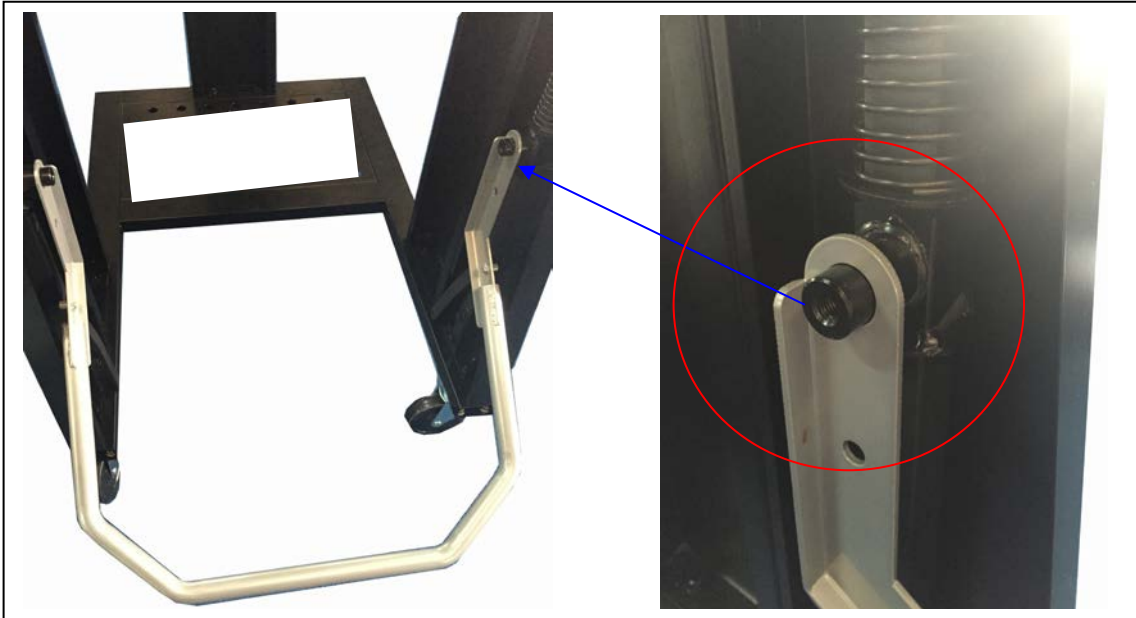
**Figure 16: Securing foot pedal support**

11. Secure the base of the foot pedal bar to the triangular support plate by holding the lower support plate vertically up against the foot pedal bar using (2) 5/16" x 3/4" hex bolts, (4) 5/16" x 3/4" flat washers and (2) 5/16" hex nuts from the inside out. Follow the same steps for the opposite side.



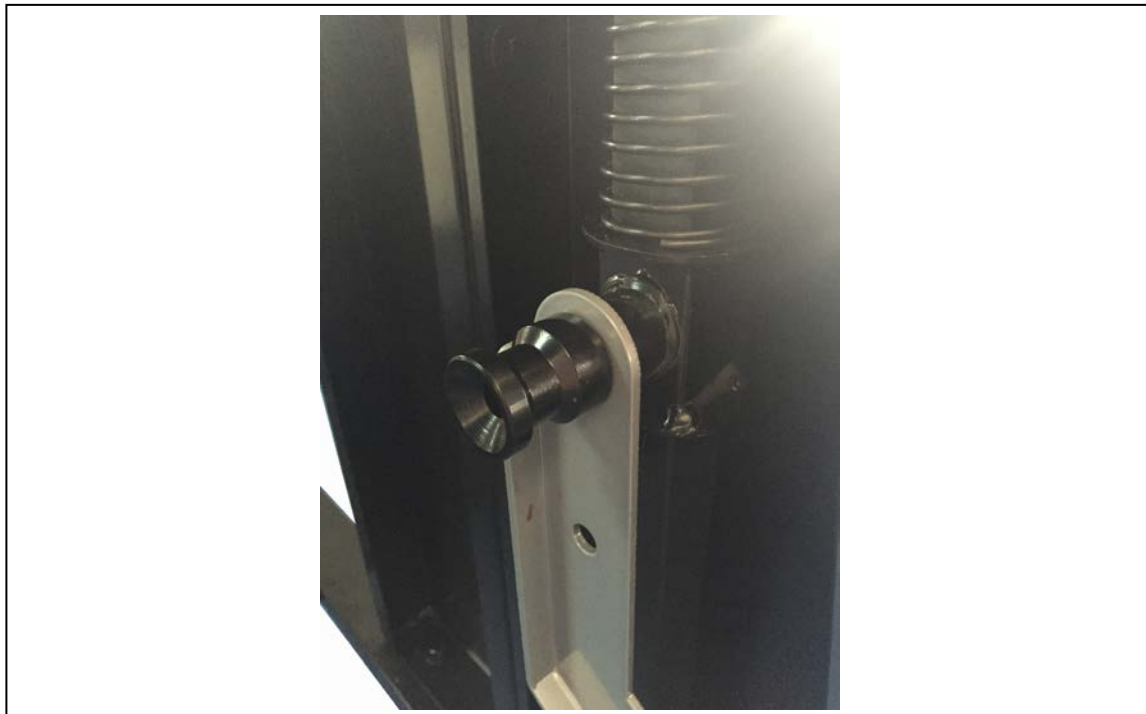
**Figure 17: Securing base of foot pedal bar**

12. Attach the two ends of the Octagon foot pedal to the nut on the foot peddle bar



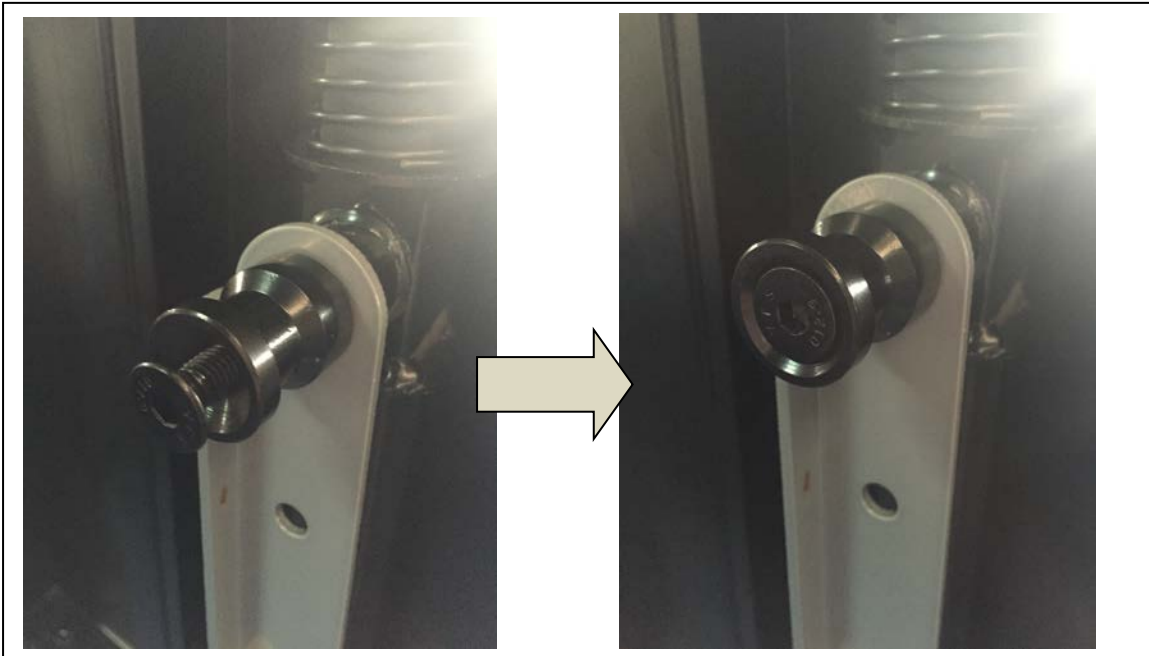
**Figure 18: Attaching ends of foot pedal to foot pedal bar**

13. Secure the topping to the nut on the foot pedal bar. Follow this step on the opposite side.



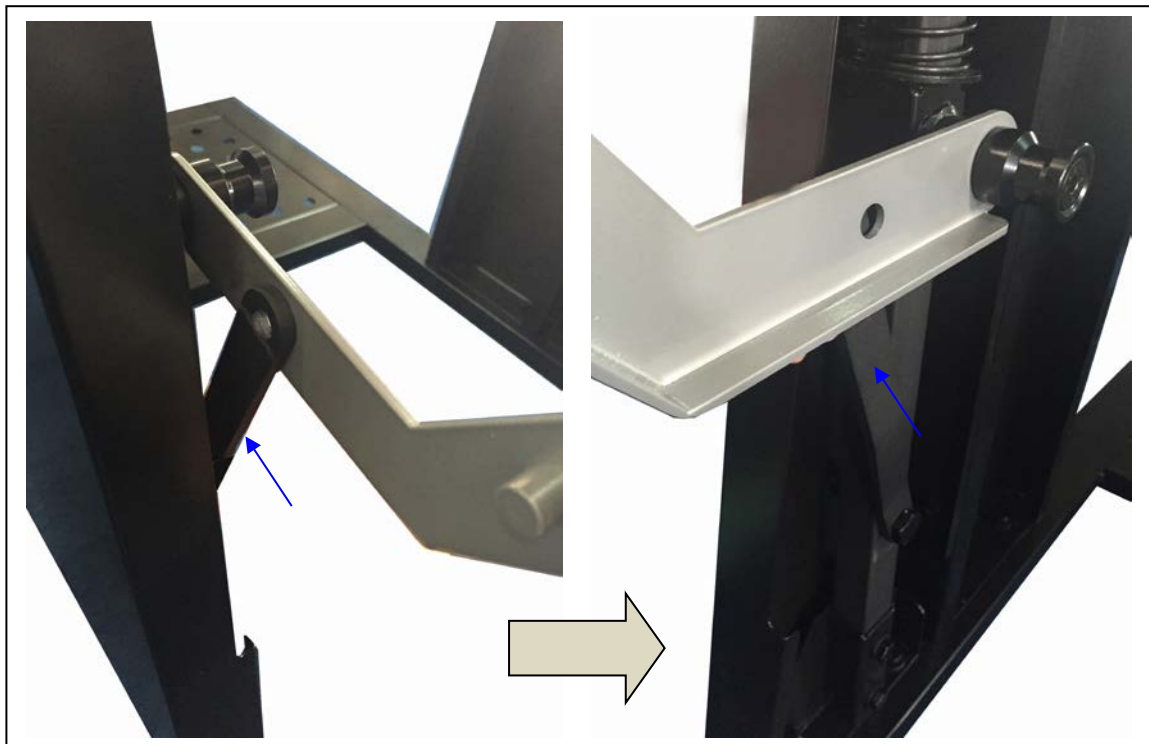
**Figure 19: Securing topping to nut on foot pedal bar**

14. Secure the topping with (2) M8 x 30mm hex bolts.



**Figure 20: Securing topping**

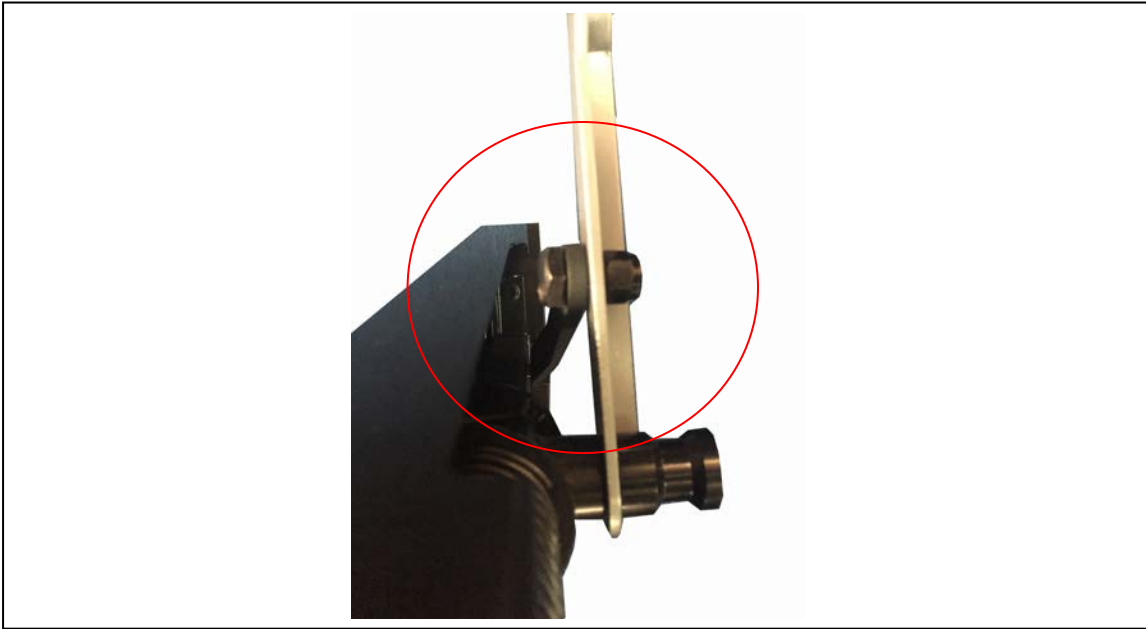
15. Align the bolt hole on the movable supporting brace on the foot pedal bar with the bolt hole on the octagon foot pedal.



**Figure 21: Aligning support brace and foot pedal**

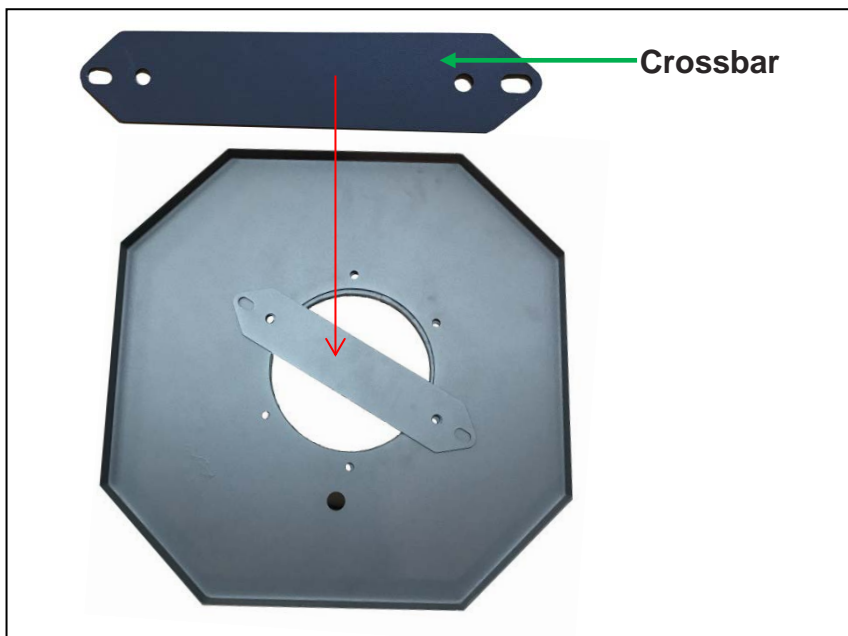
# LAGUNA

16. Secure the movable supporting brace on the foot pedal bar with the octagon foot pedal using (2) 3/8" x 13/16" hex bolts. Make sure the bolt head is on the inside of the octagon handle. Adjust the tightness of this bolt accordingly. If this bolt is too tight, the Octagon foot pedal will not work smoothly. When too loose it will not pick up the Octagon drum.



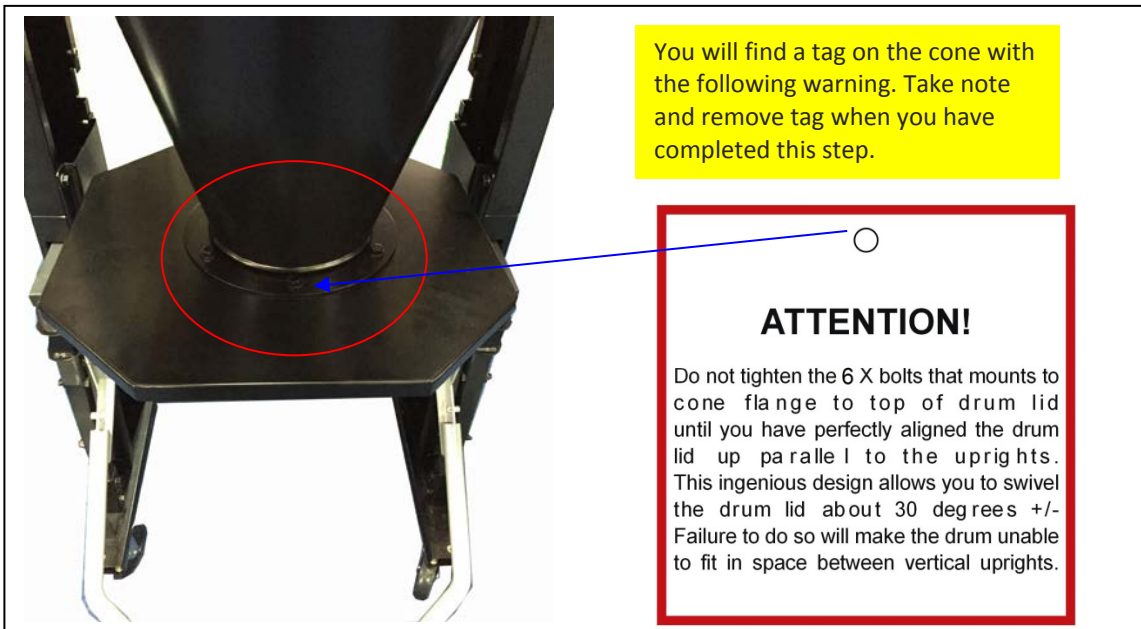
**Figure 22: Securing support brace with foot pedal**

17. Attach the crossbar to the drum lid and tighten using the two bolts removed in the previous step. It does not matter which position you attach the crossbar.



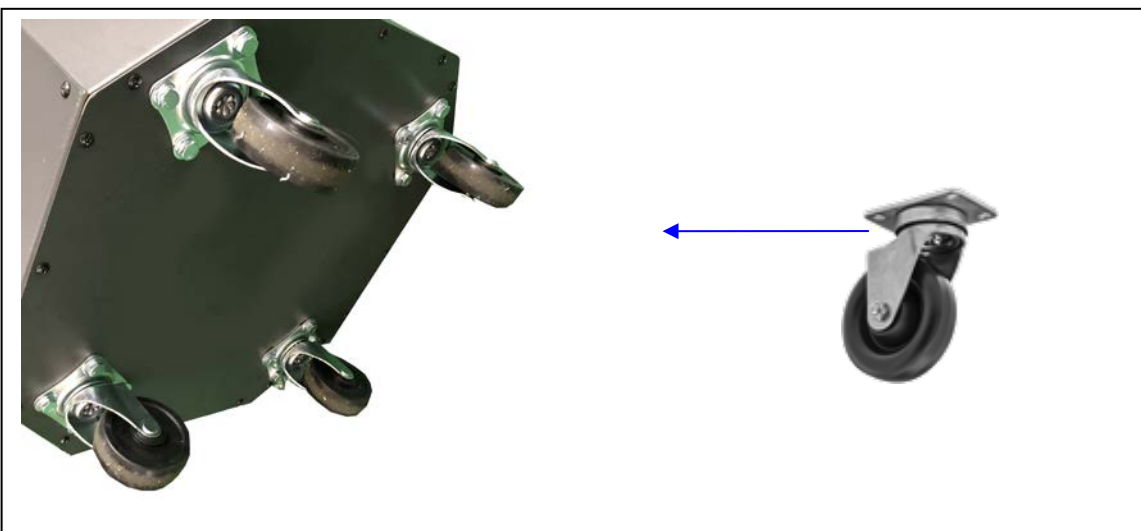
**Figure 23: Attaching crossbar to drum lid**

18. Apply foam tape to the cone flange before attaching the drum lid. Secure the Octagon drum lid to the cyclone funnel using (6) 5/16" x 3/4" hex bolts, (12) 5/16" x 1" flat washers and (6) 5/16" hex nuts. Make sure to first attach all the bolts before tightening. **NOTE: *The lid will turn when the bolts have not been tightened for alignment.*** Failure to do will result in the drum lid not being able to align with the drum.



**Figure 24: Applying foam tape and securing drum lid**

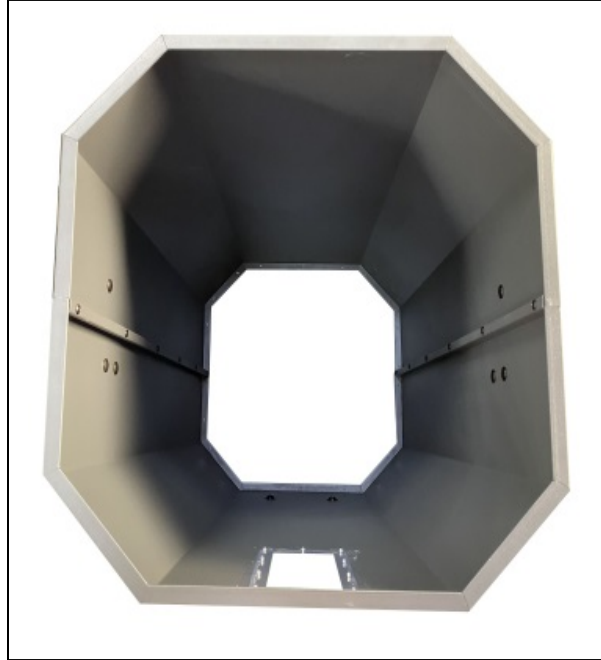
19. Locate the drum base panel, (it does not matter which side faces inside), and secure the (4) casters using (16) 5/16" x 3/4" hex bolts, (32) 5/16" x 1" flat washers and (16) 5/16" hex nuts.



**Figure 25: Installing casters**

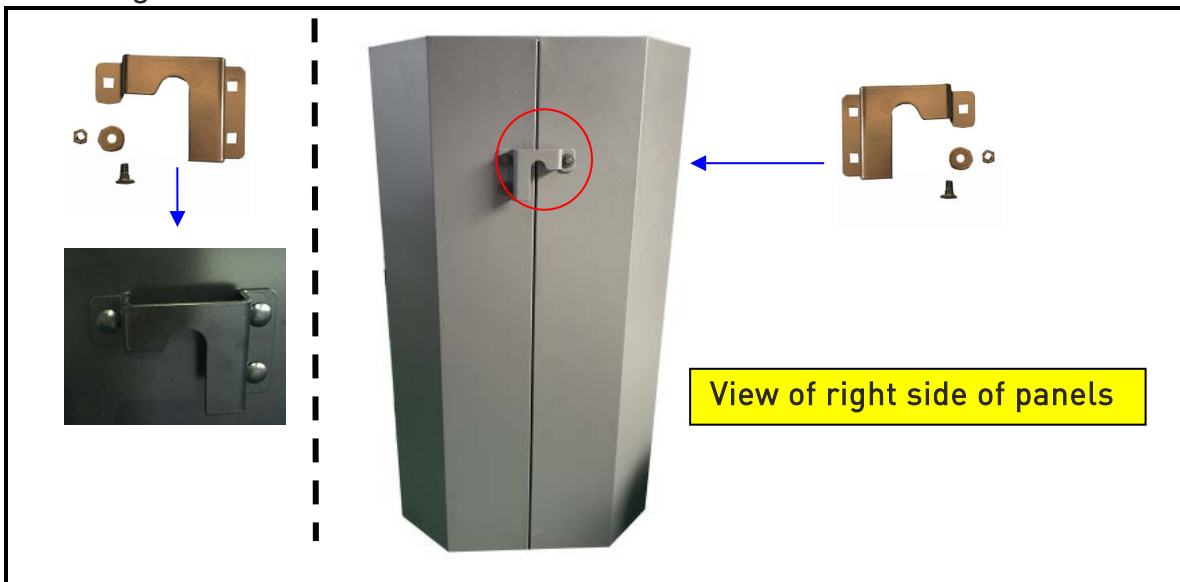
# LAGUNA

20. Assemble the Octagon drum by connecting the two panels with (12) M4 x 12mm sheet metal screws



**Figure 26: Assembling Octagon drum panels**

21. Attach each of the two side plates to the drum by fastening with three  $\frac{1}{4}$ " x  $\frac{1}{2}$ " carriage bolts. Insert the bolt from the inside of the drum with the washer and nut on the outside of the drum. Secure both brackets by tightening all six carriage bolts.



**Figure 27: Attaching side plates to drum**

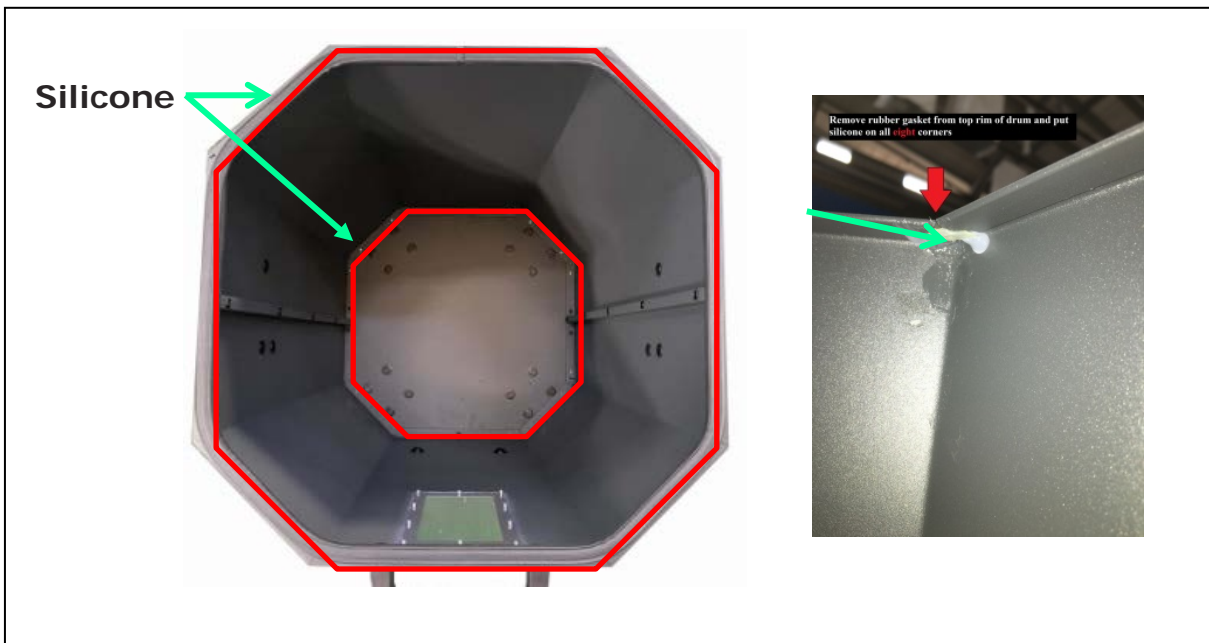
22. Place the Octagon base panel with casters on the bottom of the drum and secure using the remaining M3 x 6mm Truss head Philips flat point screws and M3 cap nuts. There will be two places you cannot use the M3 x 6mm Truss head Philips flat point screws and M3 cap nuts. You must use the (2) M4 x 12mm sheet metal screws provided for these two locations. Refer to step 20.



**Figure 28: Securing base panel to Octagon drum**

23. Once completing the assembly, keep the drum laying on its side to apply silicone to the inside of the drum including the base and the top rim of the drum before the rubber seal has been attached to seal and prevent air leakages. You will need to use a caulking gun (not supplied).

**NOTE: Sealing the perimeters with silicone is imperative for proper operation of dust collector and efficient operation!**



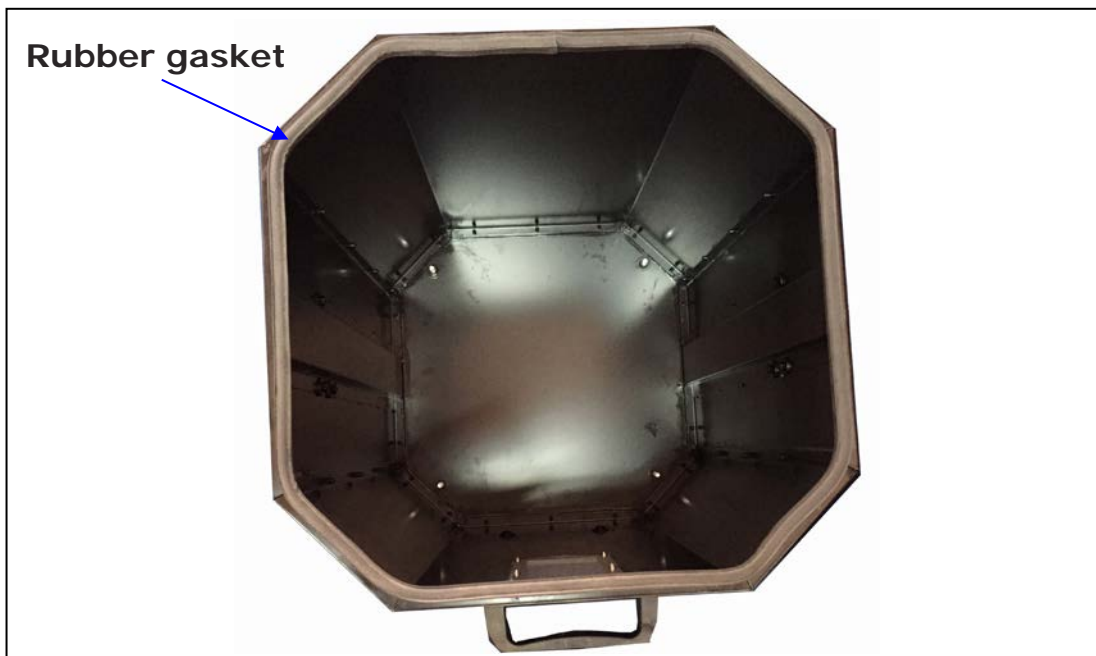
**Figure 29: Sealing drum with silicone (imperative!)**

24. Attach the handles to the top and bottom end on the front panel with the window display using (4) flat head Philip bolt, (4) 5/16" x 7/8" flat washers and (4) 5/16" hex nuts.



**Figure 30: Attaching handles**

25. Attach the rubber gasket to the top inner edges of the Octagon drum. The wider end of the gasket goes up. Use tin snips to trim any excess rubber gasket after completing the seal.



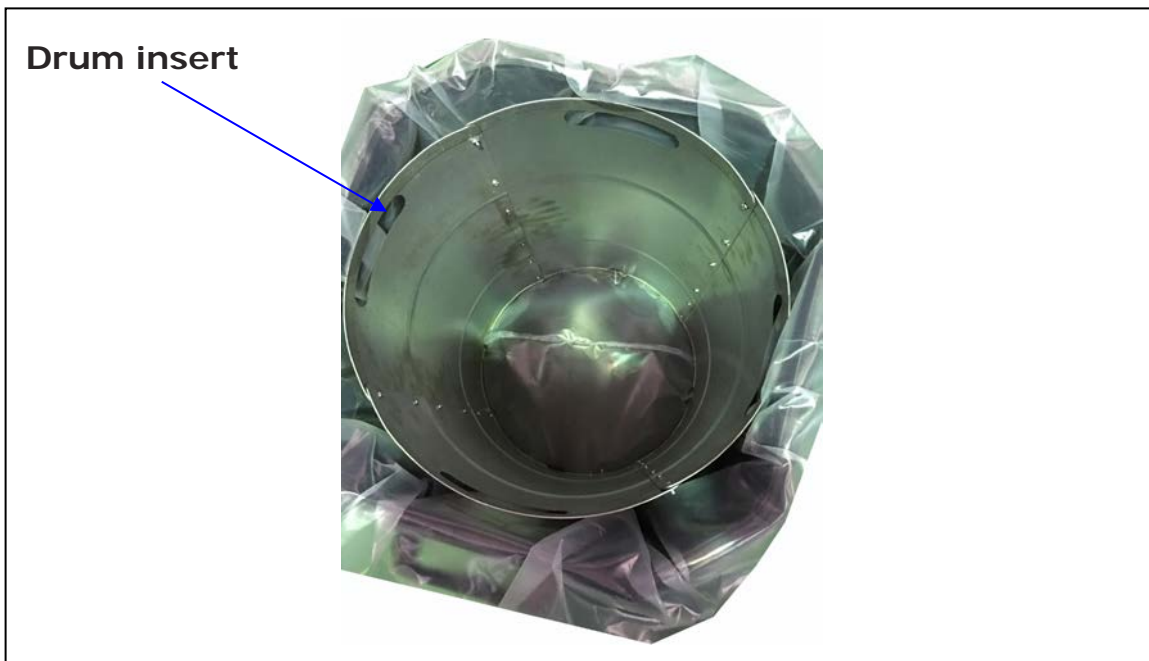
**Figure 31: Attaching gasket to Octagon drum**

26. Insert the plastic debris collection bag inside the Octagon drum. Open and spread out the plastic bag to the corners and edges



**Figure 32: Inserting plastic debris collection bag**

27. Assemble drum insert and place it inside over the plastic bag in the Octagon drum.



**Figure 33: Placing drum insert into plastic bag**

# LAGUNA

28. Lift the foot pedal bar. Align the Octagon drum window to the center point of the drum lid and push the drum in. Lower the foot pedal bar to seal the drum for normal machine operation.

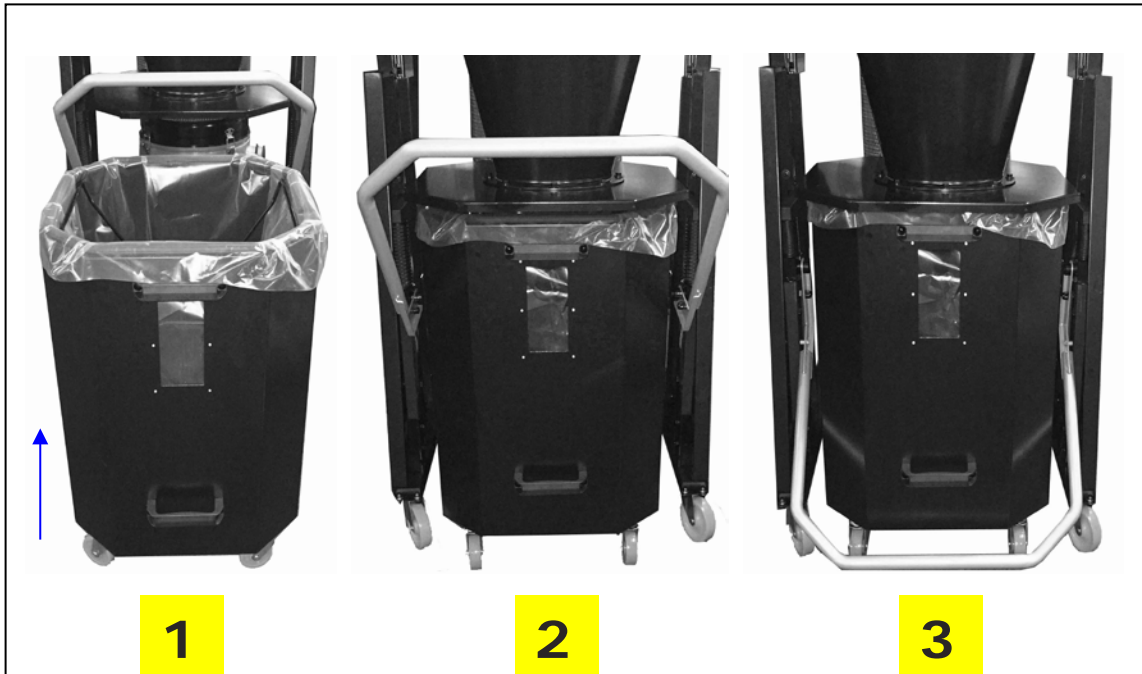


Figure 34: Placing collection drum

29. Confirm when aligning the drum that both the *left* and *right* side lift plates are over the top of the foot peddle bar assembly before lifting the foot pedal bar. *If not aligned, the drum will not be fully sealed and will interfere with air flow.*

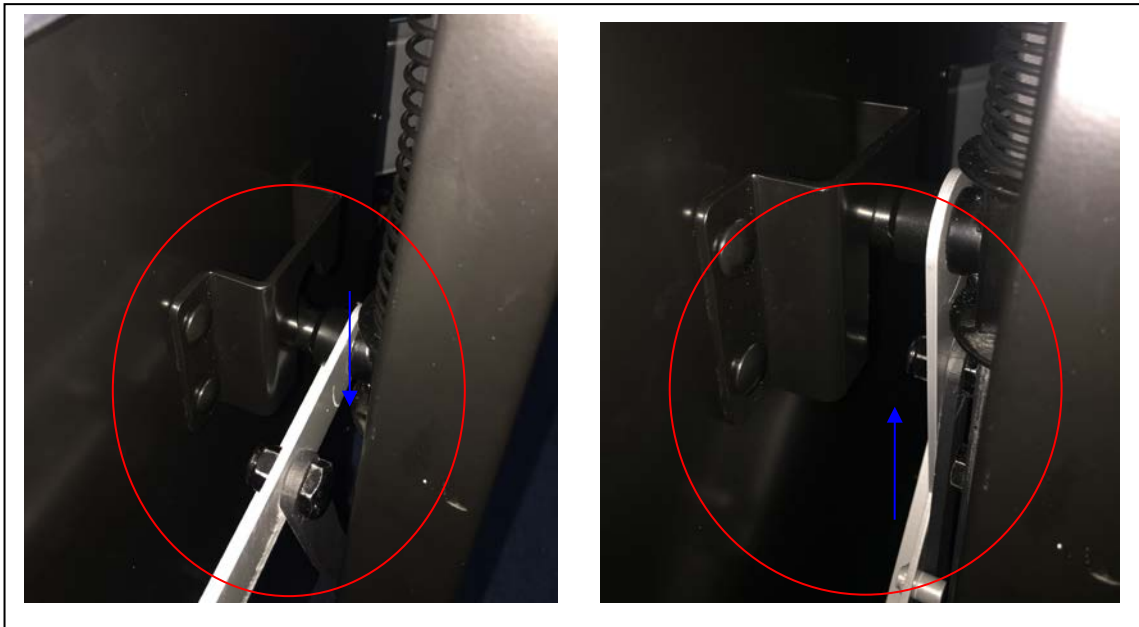
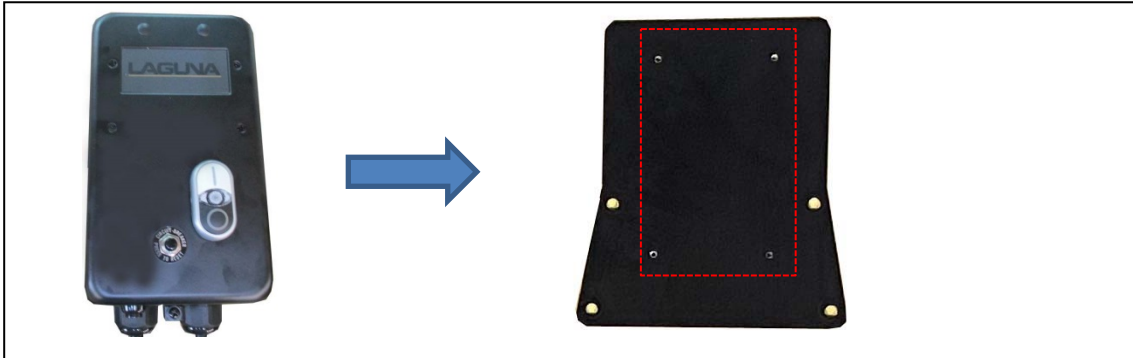


Figure 35: Confirming lift plate location

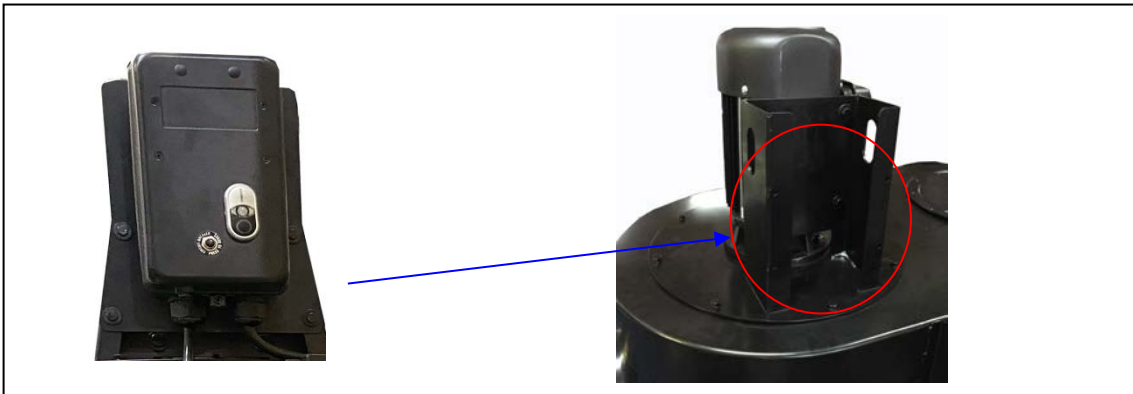
# LAGUNA

30. Take the switch box, open it by removing the bolt at the bottom of the switch box to mount to the switch base plate using (4) 3/8"×1" hex bolts, (8) 3/8" flat washers and (4) 3/8" hex nuts.



**Figure 36: Installing Switch**

31. Install the Switch Box to the switch plate on the motor using (4) 1/4" x 3/4" hex bolts, (4) 1/4" x 1" flat washers and (4) 3/8" lock washers.



**Figure 37: Installing Switch**

32. All the assembly steps have been completed.



**Figure 38: CFLUX1 complete**

# LAGUNA

## POWER SUPPLY

### Power Supply Circuit Requirements

The power source circuit for your machine must be grounded and rated for the amperage given below. Never replace a circuit breaker on an existing circuit with one of higher amperage without consulting a qualified electrician to ensure compliance with wiring codes. **If you are unsure about the wiring codes in your area or you plan to connect your machine to a shared circuit, consult a qualified electrician.**

Circuit Size (220V) .....15 Amp minimum

Circuit Size (110V) .....30 Amp minimum



IN ALL CASES, MAKE CERTAIN THE RECEPTACLE IN QUESTION IS PROPERLY GROUNDED. IF YOU ARE NOT SURE, HAVE A QUALIFIED ELECTRICIAN CHECK THE RECEPTACLE.

### 110 VOLT Single-Phase Operation

The motor supplied with your machine is a dual voltage, 110/220 Volt motor. It is shipped ready-to-run for 110 Volt operation. However, it can be converted for 220 Volt operation.

**NOTE:** An (appx.) 8' cord is included and can be used for 110 Volt or 220 Volt operation. A "plug" is NOT included and must be installed by a qualified technician.

A qualified electrician should do the conversion, or the machine can be taken to an Authorized Dealer Service Center. When completed, the machine must conform to the National Electric Code and all local codes and ordinances.

The machine is converted by re-wiring the motor for 220 Volts, and **replacing** the switch with one that is rated for 220 Volt operation.

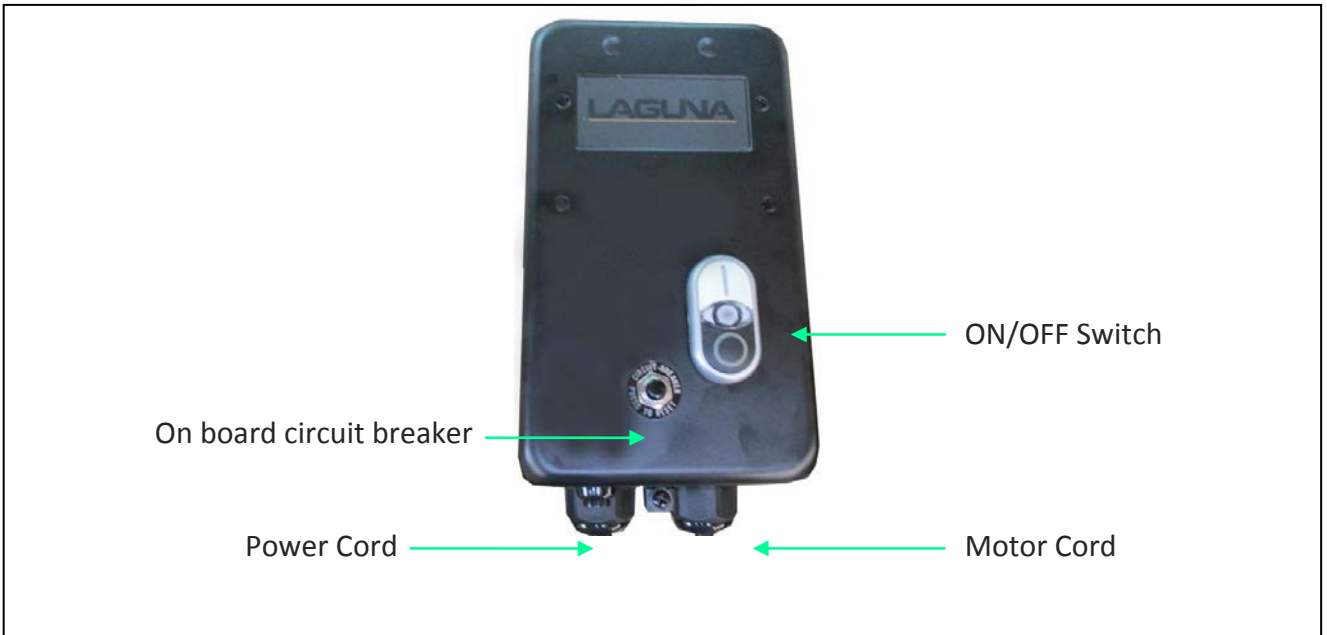
## CAUTION

### NOTICE

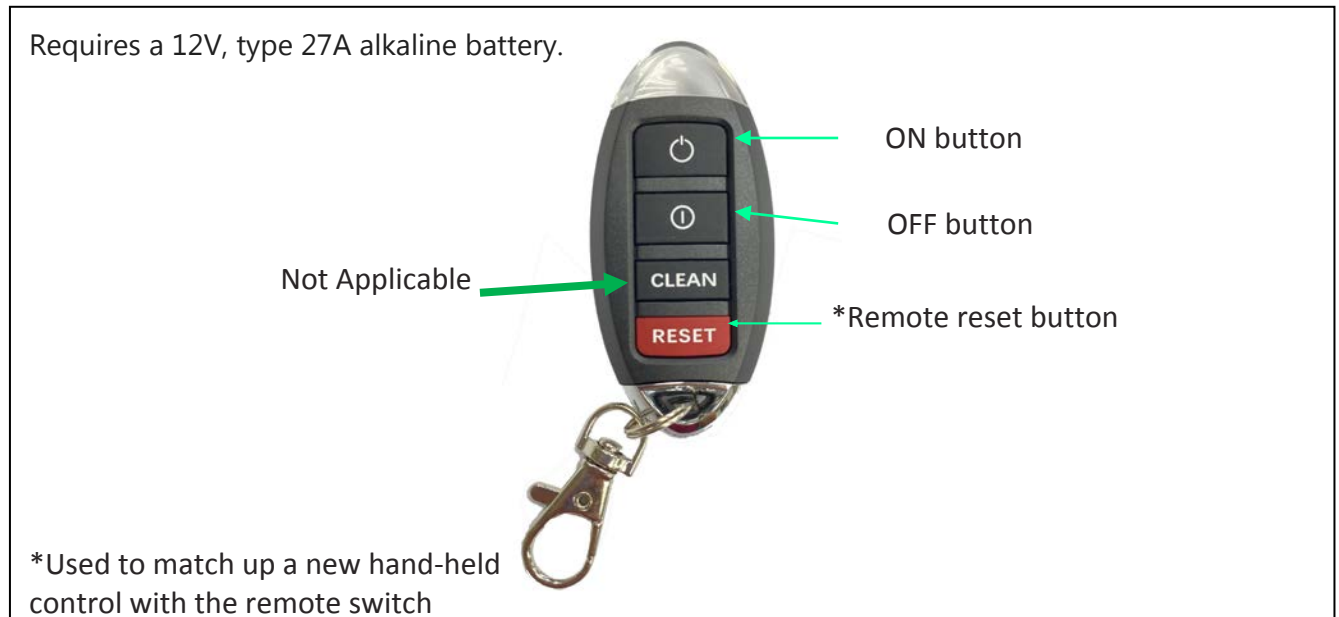
This Machine is prewired for 110V. If you plan to operate the machine at 220V, you must replace the entire control panel switch with the optional 220V control panel switch, and rewire the motor at the junction box and install a 220 V plug.

# LAGUNA

## FUNCTION



**Figure 39: Manual Switch with High Frequency Remote Control Receiver**



**Figure 40: Hand-Held Remote Control**

## PROGRAMMING THE REMOTE CONTROL

1. Confirm the machine is connected to a working outlet before programming the remote control.
2. Press and hold the Receiver “set” button (Fig. 40) on the bottom of the ON/OFF control box until you hear beeping.
3. Press the remote control “Reset” button (Fig. 40) simultaneously with the receiver “set” button until you hear beeping. Release both buttons to complete the set up.

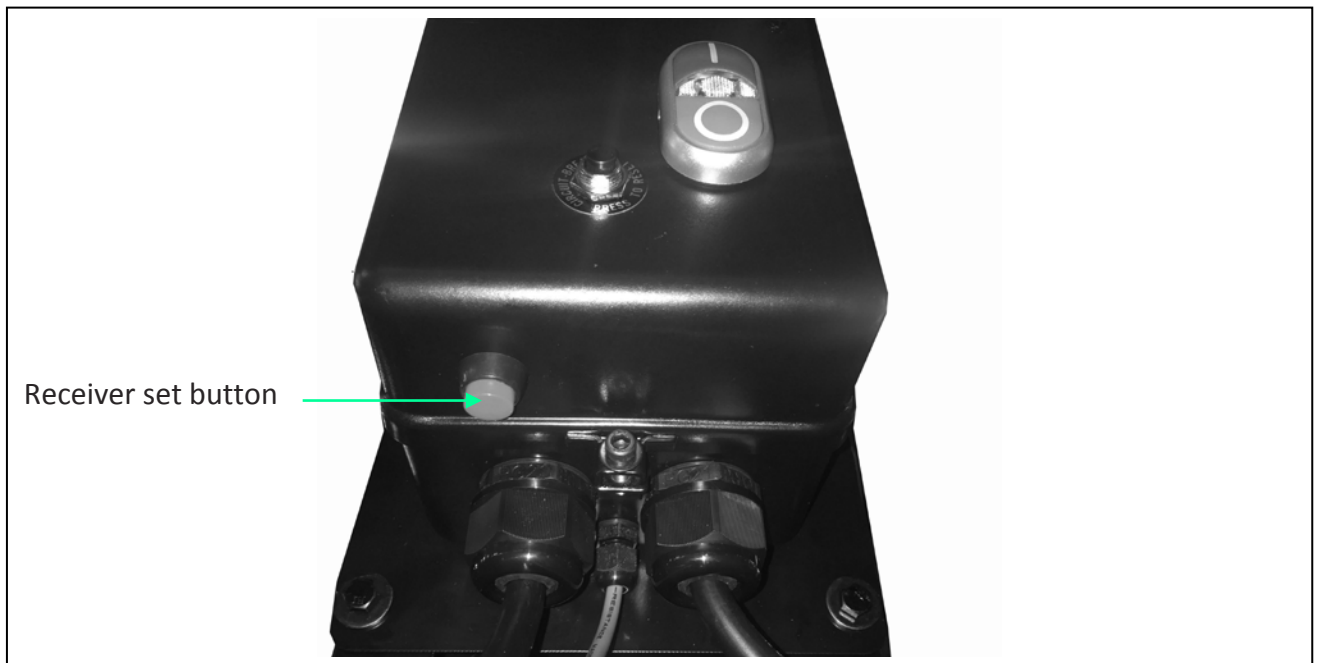


Figure 41: Programming remote control

## OPERATION

1. Make sure at least one blast gate is open, if connected to a dust collection system with blast gates.

### CAUTION

Never operate dust collector with all blast gates closed!

2. Confirm the electrical supply is correct and connected to machine.
3. Make sure no one is working on or doing maintenance to dust collector.
4. To start, press the ON button on either the ON/OFF switch (Fig. 38) or remote control, (Fig. 39).
5. To stop, press the OFF button on either the ON/OFF switch (Fig. 38) or remote control, (Fig. 39).



## MAINTENANCE

### CLEANING THE FILTER

To ensure proper operation of this Mobile Dust Cyclone, the HEPA canister filter must have adequate air flow. This means the filter must be regularly maintained by carefully blowing the filter clean using compressed air and an air gun to release built-up particulates trapped between the filter pleats.

For heavy duty users, it is recommended to use compressed air on a regular basis to maintain maximum filtration efficiency and longer life span of the filter.

### Using the Filter Cleaner Crank and Compressed Air



DISCONNECT MACHINE FROM POWER!

The filter cleaner crank knocks dust particulate and small debris from the pleated filter and into the filter bag. To improve the effectiveness of the paddles, slowly rotate the handle while simultaneously blowing (from outside – in) into the pleats. This will assist the release of fine dust from the inside of the pleats. NOTE: using the blowing function (hose connected to exhaust port) of a vacuum can also help dislodge dust.

To keep your machine in good working condition, it is recommended to use the filter cleaner crank to clean the filter after every use.

To clean the filter using the crank simply rotate the crank handle clockwise four or five rotations.

NOTE: Excessive turning of the filter cleaner crank or fast turning will prematurely wear the interior of the pleated filter.

### REMOVING THE CANISTER FILTER

1. Release the spring-loaded band clamp at the bottom of the canister filter and remove the plastic debris bag.



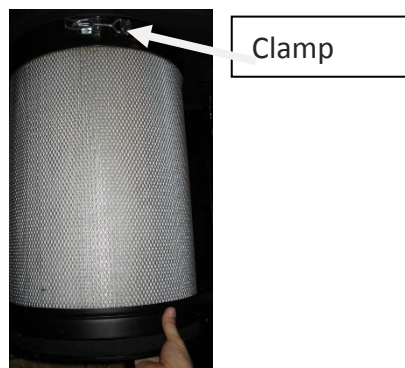
**Figure 42: Releasing collection bag clamp**

2. Remove the bolt and washer from the bottom, center of the flap pivot assembly using a 12mm wrench.

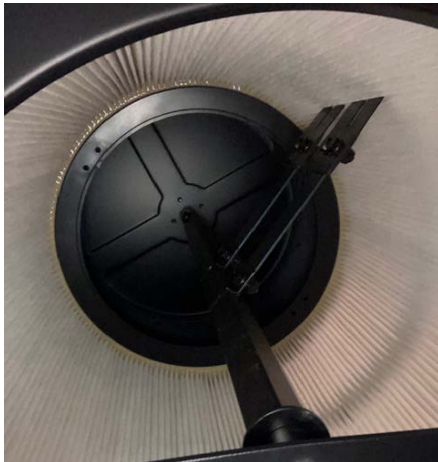


**Figure 43: Removing flap pivot bolt (from underneath)**

3. While supporting the canister filter assembly from the bottom, release the spring-loaded band clamp from the top of the canister filter assembly.



**Figure 44: Hold canister from bottom when releasing clamp (top)**



**Figures 45-46: Disassembling canister for cleaning**

4. Remove the canister filter by carefully lowering the canister. Be careful to tilt the top of canister, if necessary, to clear the paddle branches.
5. With the canister filter removed use a compressed air gun to thoroughly clean between the pleats, both inside and outside.

### **RE-ASSEMBLING THE CANISTER FILTER AFTER CLEANING**

1. With the aid of another person, carefully re-insert the canister filter repeating step 1,2,3 and 4 in reverse.

### **EMPTYING OR REPLACING THE FILTER BAG**

Periodically check the filter bag, if it is more than one third full, it is recommended that you empty it.

**NOTE:** If the filter bag gets too full, the weight may force it to pull away from the band clamp, exposing the user to potentially harmful particulates.

1. Release the spring-loaded band clamp at the bottom of the filter and remove the filter bag.
2. Empty or replace the filter bag and re-attach using the spring-loaded band clamp.



## **EMPTYING THE DRUM**

Periodically inspect the contents of the drum and empty as needed. To inspect the contents of the drum:

1. Raise the drum foot peddle bar to lower the drum to the floor.
2. Roll it away from the machine, inspect and empty as needed.

## **ROUTINE INSPECTION**

It is a good idea to routinely inspect all quality woodworking tools in order to keep them in optimum condition. This includes inspecting all hardware for tightness, ensuring filters are clean, and cleaning debris and grime from any surfaces and moving parts.



## TROUBLESHOOTING

Symptom	Possible Cause	Possible Solution
Machine does not start or a breaker trips.	Power supply switched OFF or is faulty.	Ensure power supply is <b>ON</b> and has the correct voltage.
	Wall fuse/circuit breaker is blown/tripped.	Ensure adequate circuit size; install inlet restrictor, replace weak breaker.
	Faulty remote control.	Replace batteries; ensure unobstructed line-of-sight and signal range.
	Remote receiver is faulty.	Inspect receiver circuit board; replace if faulty.
	Incorrectly wired motor connection.	Rewire or call certified service technician or electrician.
	On-board circuit breaker is tripped.	Allow motor to cool, improve ventilation, press reset button.
	Wiring is open/has high resistance.	Check for broken wires or poor connections, repair as necessary.
Excessive vibration or noise during operation.	Faulty power switch.	Replace switch.
	Motor is at fault.	Test/repair/replace.
	Loose component.	Inspect and tighten all bolts/nuts.
	Loose or broken motor mount.	Tighten or replace as needed.
	Motor fan hitting fan cover.	Check fan and cover; replace as needed.
	Bad motor bearings.	Rotate shaft manually, check for grinding or loose shaft, replace bearings if needed.

# LAGUNA

<p>Loud, repetitive noise, or excessive vibration coming from cyclone</p>	<p>Machine is on uneven surface.</p> <p>Damaged/Unbalanced impeller.</p> <p>Loose connections.</p> <p>Impeller is loose.</p> <p>Motor fan hitting fan cover.</p>	<p>Stabilize on a flat surface.</p> <p>Inspect impeller for dents, bends, loose fins. Replace if needed.</p> <p>Check and re-tighten all fasteners.</p> <p>Replace the motor and impeller.</p> <p>Check fan and cover; replace as needed.</p>
<p>Dust cyclone does not adequately collect dust or chips; poor performance.</p>	<p>Silicone was not applied to canister.</p> <p>Canister end cap is full.</p> <p>Filter is dirty.</p> <p>Restricted duct line.</p> <p>Suction route is too long or has too many sharp bends.</p> <p>Wet lumber is clogging ducts.</p> <p>Leaks in the duct work or too many open ports.</p> <p>Inadequate velocity in the main suction line.</p> <p>Wrong size ducting/ports used.</p>	<p>Clean surfaces and apply silicone! Pg. 27</p> <p>Empty canister end cap.</p> <p>Clean filter.</p> <p>Clean inlet splitter.</p> <p>Move machine closer to the point of suction, and rerun ducts to eliminate sharp bends.</p> <p>Use lumber with less than 20% moisture content.</p> <p>Repair all duct leaks and close any ports not being used.</p> <p>Increase velocity by opening 1 or 2 more blast gates to different branch lines.</p> <p>Re-size and re-install ducts and fittings.</p>
<p>Sawdust being blown into the air from the dust cyclone</p>	<p>Band clamp or end cap is not secure.</p> <p>Loose or damaged seals.</p>	<p>Re-install ensuring a tight fit.</p> <p>Replace seals and gaskets.</p>

# LAGUNA

## Parts Breakdown

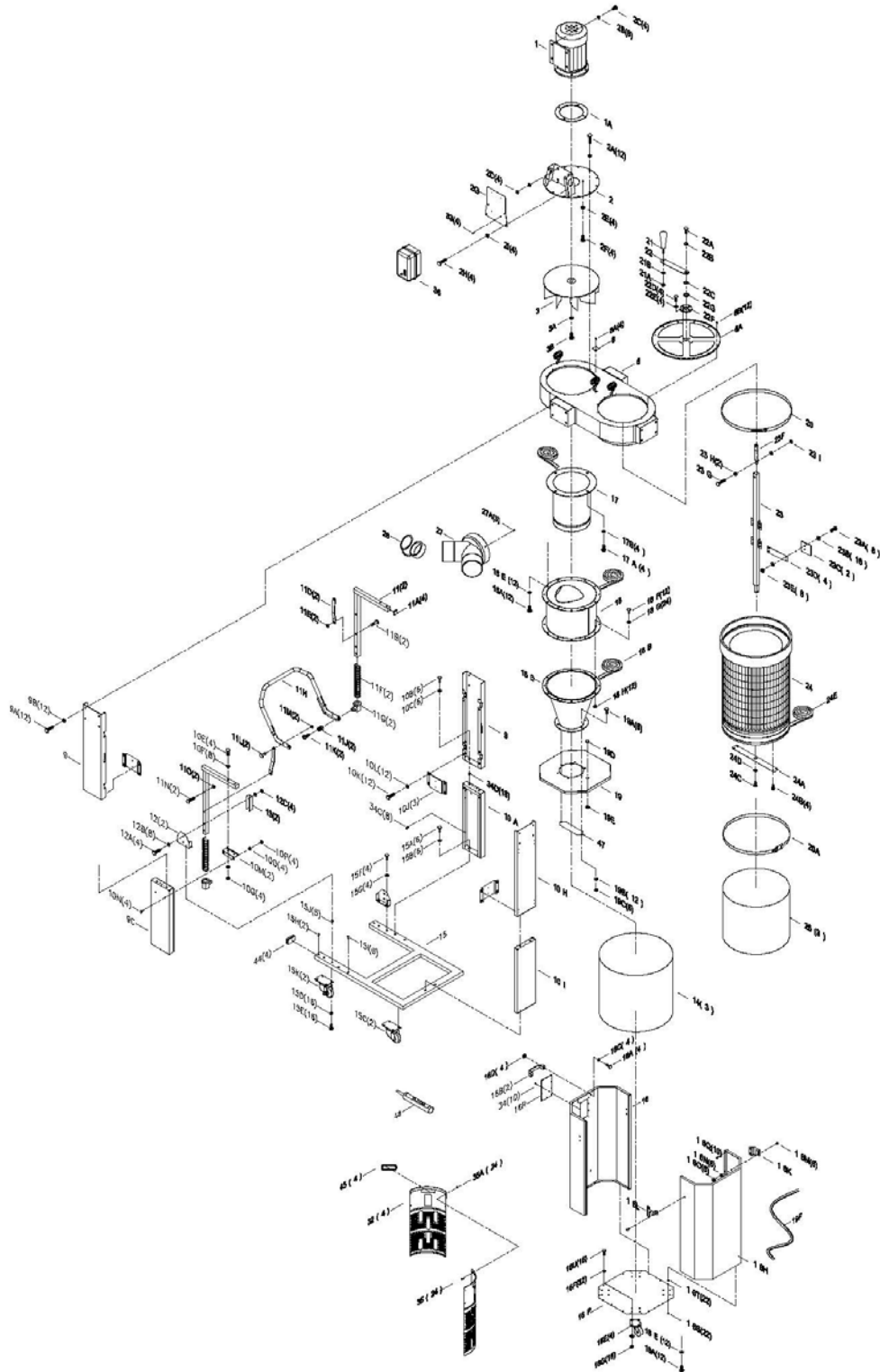


Figure 47: Main unit

# LAGUNA

## SECTION A (Close up view)

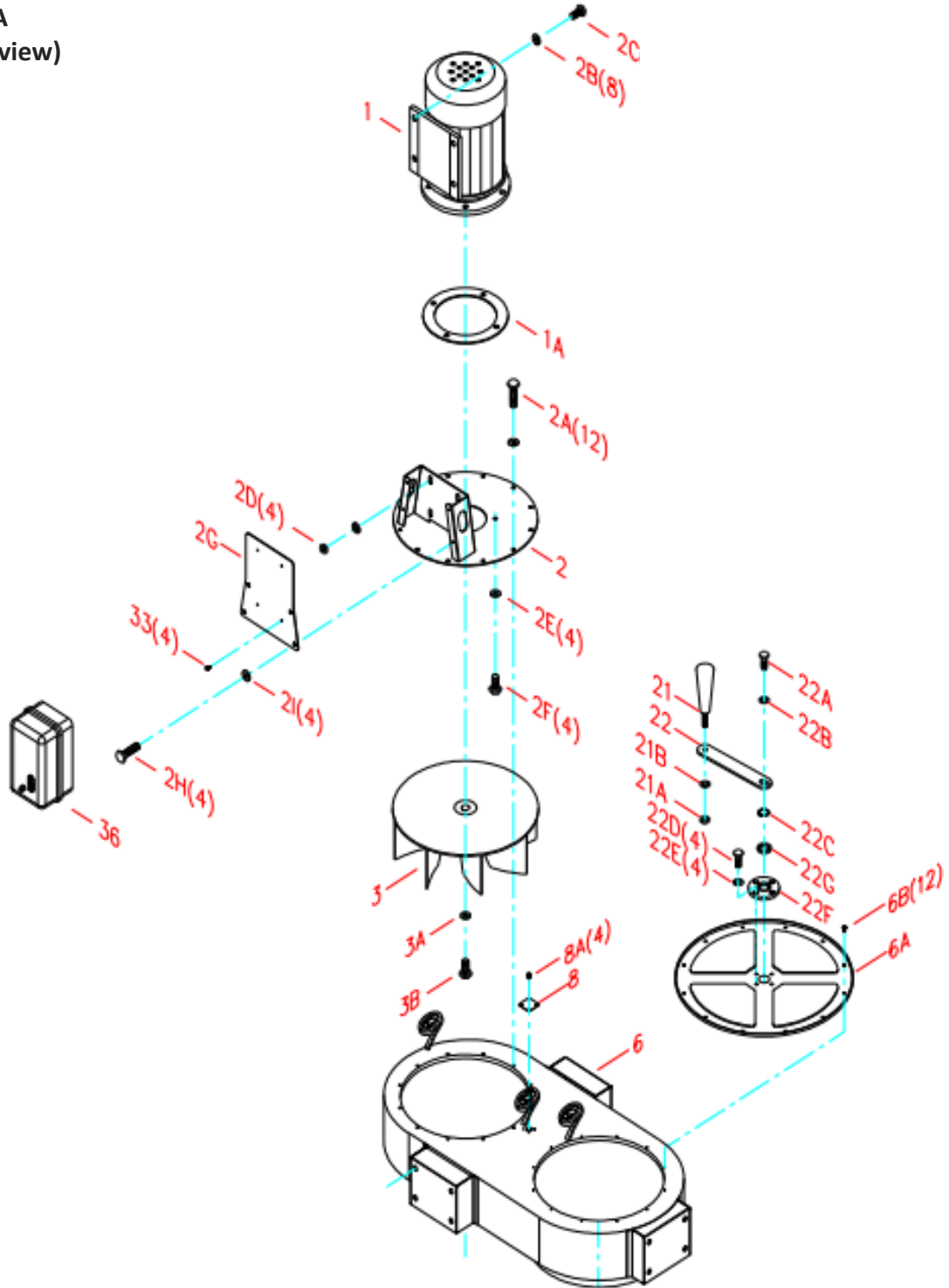


Figure 48: Fan, Motor & Switch

## SECTION B (Close up view)

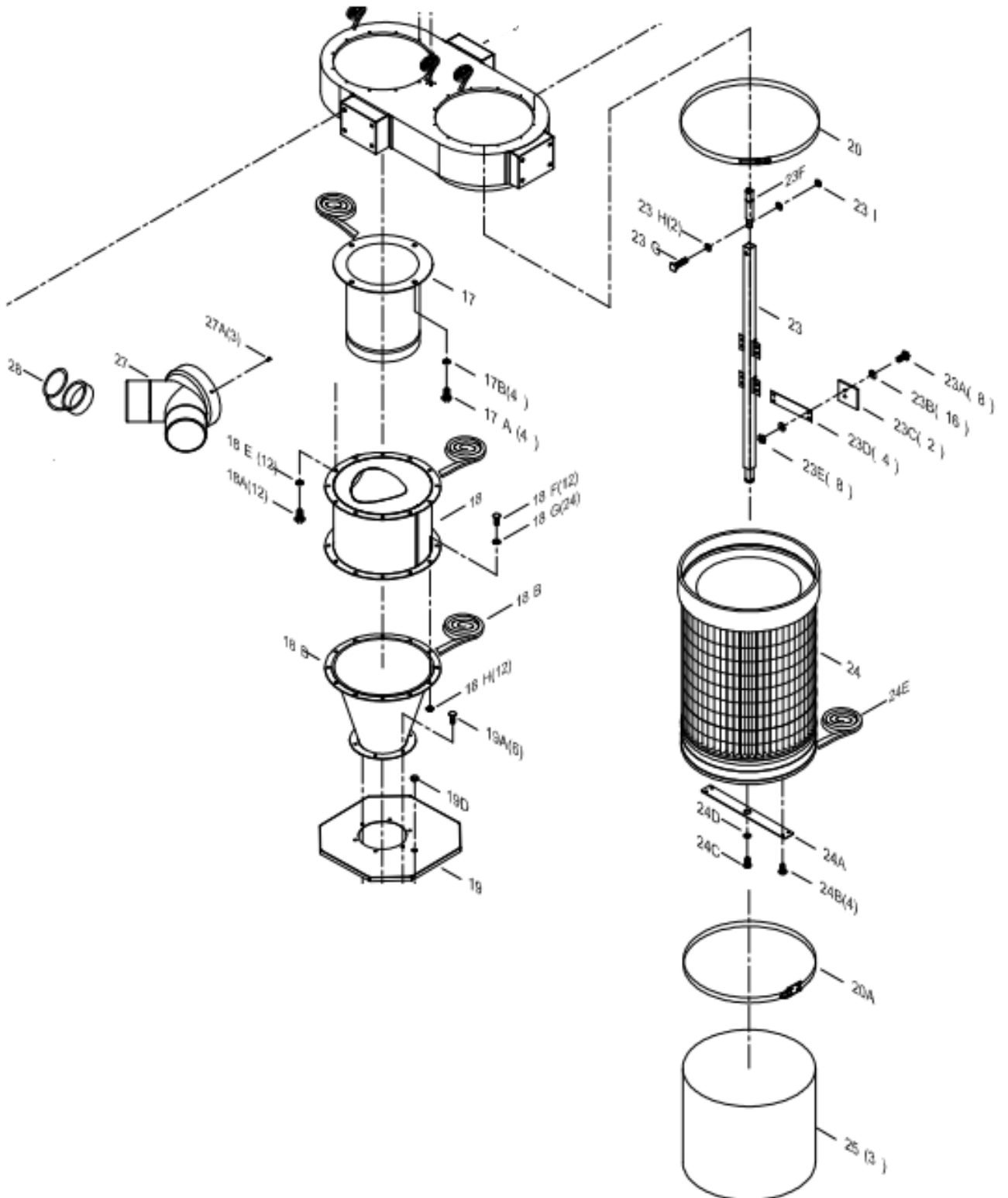


Figure 49: Cyclone, Canister & Barrel



SECTION D  
(Close up view)

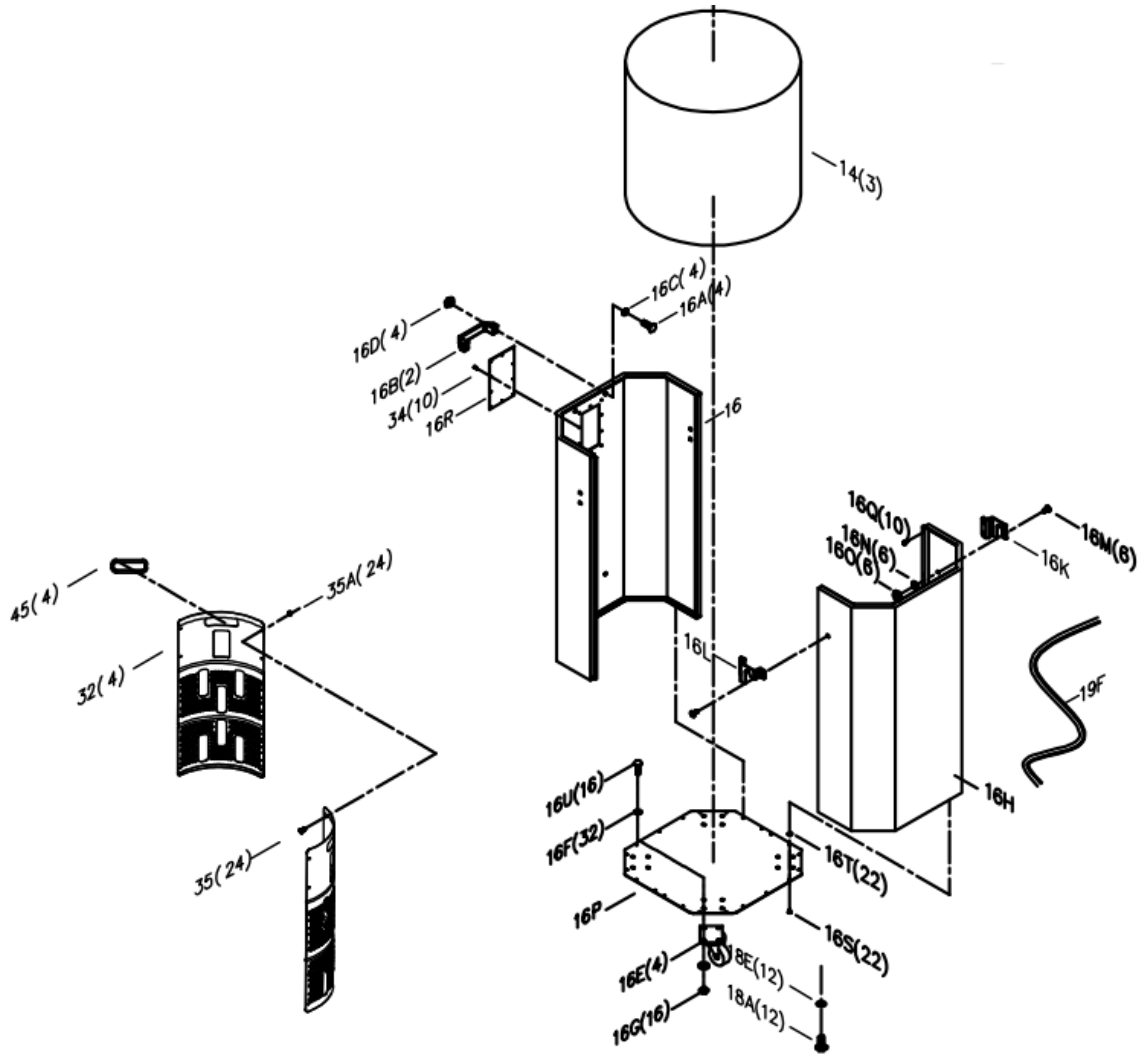


Figure 51: Barrel & insert

# LAGUNA

Parts List				
Ref #	Part Number	Part Name	Description	QTY
1	PDCCF15110-1	MOTOR	1.5HP/110V//60Hz/1Ph	1
1A	PDCCF15110-1A	MOTOR GASKET		1
2	PDCCF15110-2	MOTOR SUPPORT BASE		1
2A	PDCCF15110-2A	HEX LOCK BOLT	5/16" x 5/8"	12
2B	PDCCF15110-2B	FLAT WASHER	3/8" x 7/8"	8
2C	PDCCF15110-2C	HEX BOLT	3/8" x 1"	4
2D	PDCCF15110-2D	HEX NUT	3/8"	4
2E	PDCCF15110-2E	FLAT WASHER	5/16" x 3/4"	4
2F	PDCCF15110-2F	HEX BOLT	5/16" x 3/4"	4
2G	PDCCF15110-2G	SWITCH PLATE		1
2H	PDCCF15110-2H	HEX BOLT	1/4" x 3/4"	4
2I	PDCCF15110-2I	FLAT WASHER	1/4" x 3/4"	4
3	PDCCF15110-3	FAN	Ø 340mm	1
3A	PDCCF15110-3A	FLAT WASHER	5/16" x 1-3/16"	1
3B	PDCCF15110-3B	HEX BOLT	5/16" x 3/4"	1
6	PDCCF15110-6	DUST CHUTE		1
6A	PDCCF15110-6A	CANISTER COVER PLATE		1
6B	PDCCF15110-6B	SHEET METAL THREAD BOLT	3/16" x 1/2"	12
8	PDCCF15110-8	COVER PLATE		1
8A	PDCCF15110-8A	SHEET METAL THREAD BOLT	M4 x 12mm	4
9	PDCCF15110-9	TOP UPRIGHT SUPPORT	TWO DOT	1
9A	PDCCF15110-9A	HEX BOLT	5/16" x 3/4"	12
9B	PDCCF15110-9B	FLAT WASHER	5/16" x 3/4"	12
9C	PDCCF15110-9C	LOWER UPRIGHT SUPPORT	TWO DOT	1
10	PDCCF15110-10	TOP UPRIGHT SUPPORT	THREE DOT	1
10A	PDCCF15110-10A	LOWER UPRIGHT SUPPORT	THREE DOT	1
10B	PDCCF15110-10B	HEX BOLT	5/16" x 3/4"	6
10C	PDCCF15110-10C	FLAT WASHER	5/16" x 3/4"	6
10E	PDCCF15110-10E	HEX BOLT	5/16" x 1-3/4"	4
10F	PDCCF15110-10F	FLAT WASHER	5/16" x 3/4"	8
10G	PDCCF15110-10G	HEX NUT	5/16"	4
10H	PDCCF15110-10H	TOP UPRIGHT SUPPORT	ONE DOT	1
10I	PDCCF15110-10I	LOWER UPRIGHT SUPPORT	ONE DOT	1
10J	PDCCF15110-10J	UPRIGHT SUPPORT REINFORCEMENT PLATE		3
10K	PDCCF15110-10K	HEX BOLT	5/16" x 3/4"	12
10L	PDCCF15110-10L	FLAT WASHER	5/16" x 3/4"	12
10M	PDCCF15110-10M	FOOT PEDDLE BAR SUPPORT		2
10N	PDCCF15110-10N	CARRIAGE BOLT	5/16" x 1/2"	4

# LAGUNA

Ref #	Part Number	Part Name	Description	QTY
100	PDCCF15110-100	FLAT WASHER	5/16" x 3/4"	4
10P	PDCCF15110-10P	HEX NUT	5/16"	4
11	PDCCF15110-11	FOOT PEDDLE BAR		2
11A	PDCCF15110-11A	PLUG	25, 25	4
11B	PDCCF15110-11B	HEX BOLT	3/8" x 1-13/16"	2
11D	PDCCF15110-11D	MOVEABLE SUPPORT BRACE	208, 20, 21	2
11E	PDCCF15110-11E	HEX LOCK NUT	3/8"	2
11F	PDCCF15110-11F	SPRING	Ø 42 x 242mm L	2
11G	PDCCF15110-11G	SKID BLOCK		2
11H	PDCCF15110-11H	OCTAGON DRUM FOOT PEDDLE	520, 226, 350	1
11J	PDCCF15110-11J	TOPPING	Ø 24mm, 30mm	2
11K	PDCCF15110-11K	HEX BOLT	M8 x 30mm	2
11L	PDCCF15110-11L	HEX BOLT	3/8" x 7/8"	2
11M	PDCCF15110-11M	HEX LOCK NUT	3/8"	2
11N	PDCCF15110-11N	HEX BOLT	3/8" x 1-1/2"	2
11O	PDCCF15110-11O	HEX LOCK NUT	3/8"	2
12	PDCCF15110-12	TRIANGULAR SUPPORT PLATE	170, 102, 28	2
12A	PDCCF15110-12A	HEX BOLT	5/16" x 1-3/4"	4
12B	PDCCF15110-12B	FLAT WASHER	5/16" x 3/4"	8
12C	PDCCF15110-12C	HEX NUT	5/16"	4
13	PDCCF15110-13	LOWER SUPPORT PLATE	30, 28, 98	2
<b>14</b>	<b>PDCCF15110-14V2</b>	<b>PLASTIC BAG</b>	<b>Ø 610 x 1200mm</b>	3
15	PDCCF15110-15	BASE		1
15A	PDCCF15110-15A	HEX BOLT	3/8" x 3/4"	6
15B	PDCCF15110-15B	FLAT WASHER	3/8" x 7/8"	6
15C	PDCCF15110-15C	SWIVEL CASTER	4"	2
15D	PDCCF15110-15D	FLAT WASHER	5/16" x 3/4"	16
15E	PDCCF15110-15E	HEX BOLT	5/16" x 3/4"	16
15F	PDCCF15110-15F	HEX BOLT	5/16" x 3/4"	4
15G	PDCCF15110-15G	FLAT WASHER	5/16" x 3/4"	4
15H	PDCCF15110-15H	RIVET NUT	1/4"	2
15I	PDCCF15110-15I	RIVET NUT	3/8"	6
15J	PDCCF15110-15J	RIVET NUT	5/16"	5
<b>15K</b>	<b>PDCCF15110-15K</b>	<b>SWIVEL CASTER WITH BRAKES</b>	<b>4"</b>	<b>2</b>
<b>16</b>	<b>PDCCF15110-16V2</b>	<b>OCTAGON DRUM FRONT PANEL</b>		<b>1</b>
16A	PDCCF15110-16A	FLAT HEAD PHILIP BOLT	5/16" x 3/4"	4
16B	PDCCF15110-16B	HANDLE		2
16C	PDCCF15110-16C	FLAT WASHER	5/16" x 7/8"	4
16D	PDCCF15110-16D	HEX NUT	5/16"	4
16E	PDCCF15110-16E	DRUM CASTER		4

# LAGUNA

Ref #	Part Number	Part Name	Description	QTY
16U	PDCCF15110-16U	HEX BOLT	5/16" x 3/4"	16
16F	PDCCF15110-16F	FLAT WASHER	5/16" x 3/4"	32
16G	PDCCF15110-16G	HEX NUT	5/16"	16
<b>16H</b>	<b>PDCCF15110-16HV2</b>	<b>OCTAGON DRUM BACK PANEL</b>		<b>1</b>
16K	PDCCF15110-16K	LEFT SIDE PLATE		1
16L	PDCCF15110-16L	RIGHT SIDE PLATE		1
16M	PDCCF15110-16M	CARRIAGE BOLT	1/4" x 1/2"	6
16N	PDCCF15110-16N	FLAT WASHER	1/4" x 1"	6
16O	PDCCF15110-16O	HEX NUT	1/4"	6
<b>16P</b>	<b>PDCCF15110-16PV2</b>	<b>OCTAGON DRUM BASE PANEL</b>		<b>1</b>
16R	PDCCF15110-16R	WINDOW		1
16S	PDCCF15110-16S	TRUSS HEAD PHILIP FLAT POINT SCREW	M3 x 6mm	22
16T	PDCCF15110-16T	CAP NUT	M3	22
16Q	PDCCF15110-16Q	THREAD BOLT	M4 x 12mm	10
17	PDCCF15110-17	INTAKE CYLINDER		1
17A	PDCCF15110-17A	HEX BOLT	5/16" x 5/8"	4
17B	PDCCF15110-17B	FLAT WASHER	5/16" x 3/4"	4
18	PDCCF15110-18	CYCLONE BARREL	5/16" x 3/4"	1
18A	PDCCF15110-18A	HEX BOLT	5/16" x 3/4"	12
18B	PDCCF15110-18B	FOAM TAPE	3 x 6mm x 10M	1
18D	PDCCF15110-18D	CYCLONE FUNNEL		1
18E	PDCCF15110-18E	FLAT WASHER	5/16" x 3/4"	12
18F	PDCCF15110-18F	HEX BOLT	5/16" x 3/4"	12
18G	PDCCF15110-18G	FLAT WASHER	5/16" x 3/4"	24
18H	PDCCF15110-18H	HEX NUT	5/16"	12
19	PDCCF15110-19	OCTAGON DRUM LID		1
19A	PDCCF15110-19A	HEX BOLT	5/16" x 3/4"	6
19B	PDCCF15110-19B	FLAT WASHER	5/16" x 3/4"	12
19C	PDCCF15110-19C	HEX NUT	5/16"	6
19D	PDCCF15110-19D	PLUG	MSP-16	1
19E	PDCCF15110-19E	NUT	AGL-16	1
19F	PDCCF15110-19F	RUBBER GASKET	1400mm	1
20	PDCCF15110-20	BAND CLAMP	Ø 400mm	1
20A	PDCCF15110-20A	SPRING BAND CLAMP	Ø 400mm	1
21	PDCCF15110-21	ROTATION HANDLE		1
21A	PDCCF15110-21A	HEX LOCK NUT	3/8"	1
21B	PDCCF15110-21B	FLAT WASHER	3/8" x 7/8"	1
22	PDCCF15110-22	ROTATION CRANK	210, 35, 4.5t	1
22A	PDCCF15110-22A	HEX BOLT	5/16" x 3/4"	1
22B	PDCCF15110-22B	FLAT WASHER	5/16" x 1-3/16"	1

# LAGUNA

Ref No	Part number	Part Name	Description	QTY
22C	PDCCF15110-22C	GEAR	Ø20mm	1
22D	PDCCF15110-22D	HEX BOLT	1/4" x 3/4"	4
22E	PDCCF15110-22E	FLAT WASHER	1/4" x 3/4"	4
22F	PDCCF15110-22F	BEARING	Ø70, Ø20.5, 7t	1
22G	PDCCF15110-22G	SEAL		1
<b>23</b>	<b>PDCCF15110-23V2</b>	<b>ROTATION SHAFT</b>		<b>1</b>
23A	PDCCF15110-23A	HEX BOLT	1/4" x 5/8"	8
23B	PDCCF15110-23B	FLAT WASHER	1/4" x 1/2"	16
23C	PDCCF15110-23C	PADDLE		2
23D	PDCCF15110-23D	PADDLE BRANCH		4
23E	PDCCF15110-23E	HEX LOCK NUT	1/4"	8
23F	PDCCF15110-23F	ROTATION SHAFT CONNECTION		1
23G	PDCCF15110-23G	HEX BOLT	5/16" x 1-1/2"	1
23H	PDCCF15110-23H	FLAT WASHER	5/16" x 3/4"	2
23I	PDCCF15110-23I	HEX LOCK NUT	5/16"	1
24	PDCCF15110-24	CANISTER FILTER	Ø 400x611mm L	1
24A	PDCCF15110-24A	ROTATION SHAFT BASE		1
24B	PDCCF15110-24B	SHEET METAL PHILIPS BOLT	3/16" x 3/4"	4
24C	PDCCF15110-24C	HEX BOLT	5/16" x 3/4"	1
24D	PDCCF15110-24D	FLAT WASHER	5/16" x 7/8"	1
24E	PDCCF15110-24E	FOAM TAPE	3 x 25mm x 1.5M	1
25	PDCCF15110-25	PLASTIC BAG	Ø 400 x 600mm	3
27	PDCCF15110-27	INTAKE MANIFOLD	6"X1 / 4"X2 ports	1
27A	PDCCF15110-27A	SHEET METAL BOLT	M4 x 12mm	3
28	PDCCF15110-28	RUBBER CAP	4"	1
32	PDCCF15110-32	DRUM INSERT		4
33	PDCCF15110-33	FLAT HEAD BOLT	M4 x 6mm	4
34	PDCCF15110-34	RIVET	3-2	10
34A	PDCCF15110-34A	FLAT WASHER	1/8" x 5/16"	6
34C	PDCCF15110-34C	RIVET NUT	1/4"	8
34D	PDCCF15110-34D	RIVET NUT	5/16"	18
35	PDCCF15110-35	ROUND HD BOLT	3/16" x 1/2"	24
35A	PDCCF15110-35A	NUT	3/16"	24
<b>36</b>	<b>PDCCF15110-36V2</b>	<b>FREQUENCY REMOTE SWITCH</b>		<b>1</b>
44	PDCCF15110-44	RUBBER PLUG	30 x 60mm	4
45	PDCCF15110-45	RUBBER HANDLE FOR DRUM INSERT		4
46	PDCCF15110-46	SILICONE	Tube	1
47	PDCCF15110-47	CROSSBAR		1



## SPECIFICATIONS: CFLUX1

Motor Specs:	1.5 HP
Electrical Specs:	110V/220V / 60Hz / 1PH / 3450 RPM
Running AMP	(with 6" inlet) 18.8A at 110V; 9.4A at 220V
Air Volume:	900CFM (cubic feet per minute)
Max. static pressure	10.1 Inches of water
Fan size	Ø 340mm
Inlet:	One 6" or two 4" ports
Switch	High frequency remote control switch
Collection capacity	25 gallon octagon drum
Packing Size: (L x W x H)	43.7" x 27.2" x 46.1" (111 x 69 x 117 cm)
Machine weight	232 lbs. (105 kgs)
Shipping weight	287 lbs. (130 kgs)

<u>Filter Media</u>	Filtering area: 48.4 sq./ft. (4.5 m <sup>2</sup> )
Cartridge Filter	1 Micron, 15.74" x 19.68" (40 x 50cm) x 1pc

## SUPPLIES:

Plastic debris collection bag, 20 gallon

SKU/Part # PDCCF-FB22

Ph: 800.234.1976

[www.lagunatools.com](http://www.lagunatools.com)

# LAGUNA

---



**LAGUNA TOOLS**  
744 Refuge Way  
Suite 200  
Grand Prairie TX 75050  
Ph: 800.234.1976  
[www.lagunatools.com](http://www.lagunatools.com)

090721 REV2021.09

1.5HP Mobile Dust Cyclone Manual