

OWNER'S MANUAL

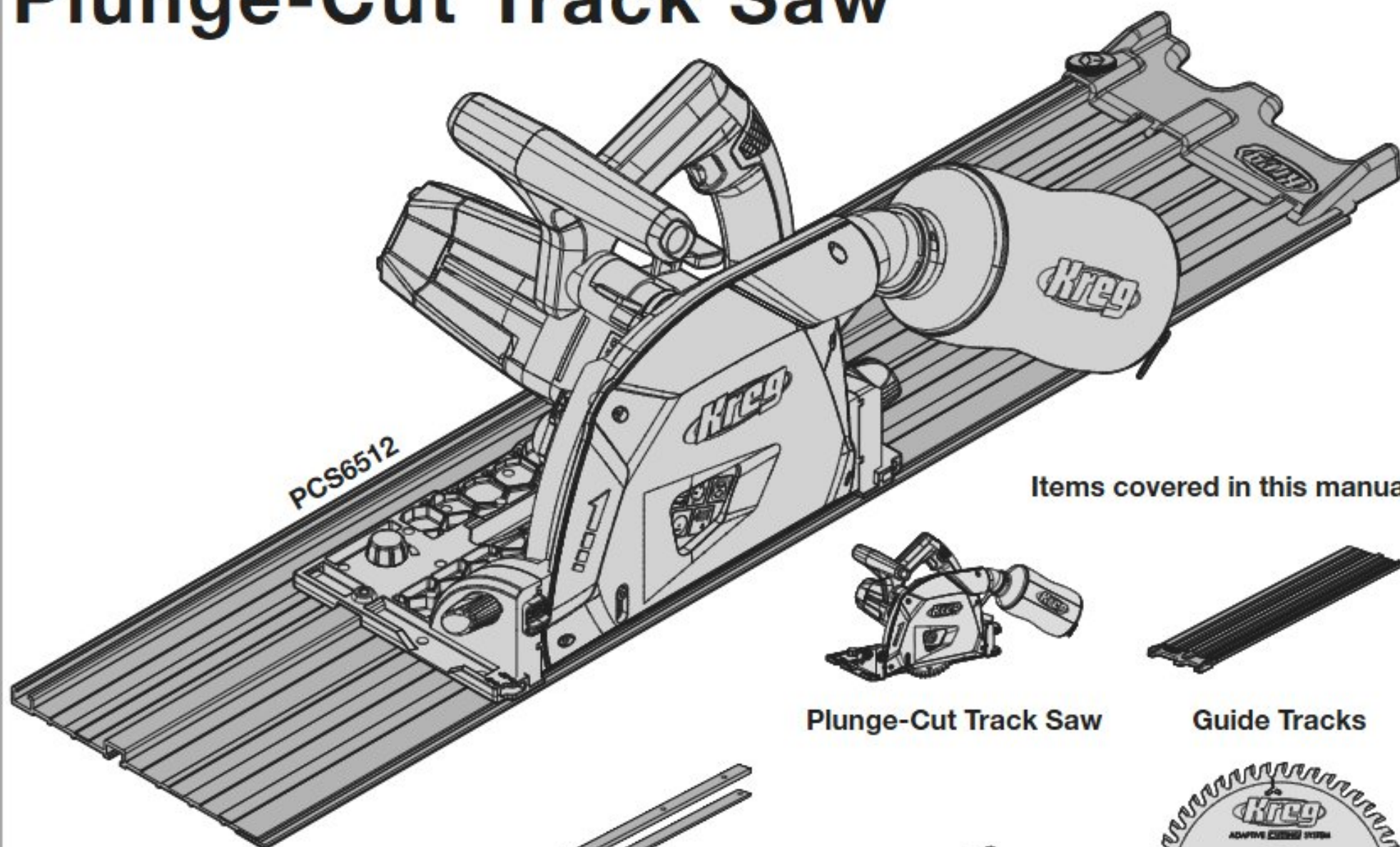

**ADAPTIVE
CUTTING
SYSTEM**

Plunge-Cut Track Saw



PCS6512

Items covered in this manual:



Plunge-Cut Track Saw



Guide Tracks



Guide Track Connectors

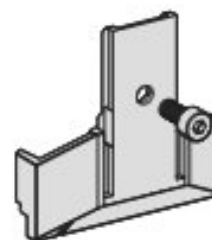

Saw Splinter Guard



Saw Blade



WARNING Every user must read and follow instructions and safety precautions in this manual. Failure to do so could result in serious injury. Save manual for future reference.

We're here to help.

We want you to have an exceptional project building experience. If you have questions or need support, please get in touch.
1-800-447-8638 | technicalsupport@kregtool.com

Tell us about your experience.

Your opinion counts. And we're always looking for ways to improve. Share your feedback so we can keep growing and innovating for you.
www.kregtool.com/feedback

English	2
French	35
Spanish	69

Table of Contents

Safety Precautions	2	Care and Cleaning	24
Pre-Assembly	7	Cleaning	24
Guide Track Components	7	Lubrication	24
Guide Track Connector Components	7	Motor Brushes	24
Joining Guide Track Sections	8	Periodic Inspections	24
Saw Components	10	Accessories	25
Assembly	12	Troubleshooting	26
Correct Blade-Tooth Orientation	20	Replacement Parts	28
Incorrect Blade-Tooth Orientation	20	Warranty	33
Operation	21		
Bevel Overrides	22		

Safety Precautions

SAVE ALL WARNINGS AND INSTRUCTIONS FOR FUTURE REFERENCE

⚠ WARNING Read all safety warnings, instructions, illustrations, and specifications provided with this power tool. Failure to follow all instructions listed below may result in electric shock, fire, and/or serious injury.

The term “power tool” in the warnings refers to your mains-operated (corded) power tool or battery-operated (cordless) power tool.

Work Area Safety

- Keep work area clean and well lit. Cluttered or dark areas invite accidents.
- Do not operate power tools in explosive atmospheres, such as in the presence of flammable liquids, gases or dust. Power tools create sparks which may ignite the dust or fumes.
- Keep children and bystanders away while operating a power tool. Distractions can cause you to lose control.

Electrical Safety

- Power tool plugs must match the outlet. Never modify the plug in any way. Do not use any adapter plugs with earthed (grounded) power tools. Unmodified plugs and matching outlets will reduce risk of electric shock.
- Avoid body contact with earthed or grounded surfaces, such as pipes, radiators, ranges and refrigerators. There is an increased risk of electric shock if your body is earthed or grounded.
- Do not expose power tools to rain or wet conditions. Water entering a power tool will increase the risk of electric shock.

- Do not abuse the cord. Never use the cord for carrying, pulling or unplugging the power tool. Keep cord away from heat, oil, sharp edges or moving parts. Damaged or entangled cords increase the risk of electric shock.
- When operating a power tool outdoors, use an extension cord suitable for outdoor use. Use of a cord suitable for outdoor use reduces the risk of electric shock.
- If operating a power tool in a damp location is unavoidable, use a ground fault circuit interrupter (GFCI) protected supply. Use of a GFCI reduces the risk of electric shock.

Personal Safety

- Stay alert, watch what you are doing and use common sense when operating a power tool. Do not use a power tool while you are tired or under the influence of drugs, alcohol or medication. A moment of inattention while operating power tools may result in serious personal injury.
- Use personal protective equipment. Always wear eye protection. Protective equipment such as dust mask, non-skid safety shoes, hard hat, or hearing protection used for appropriate conditions will reduce personal injuries.

- Prevent unintentional starting. Ensure the switch is in the off-position before connecting to power source and/or battery pack, picking up or carrying the tool. Carrying power tools with your finger on the switch or energizing power tools that have the switch on invites accidents.
- Remove any adjusting key or wrench before turning the power tool on. A wrench or a key left attached to a rotating part of the power tool may result in personal injury.
- Do not overreach. Keep proper footing and balance at all times. This enables better control of the power tool in unexpected situations.
- Dress properly. Do not wear loose clothing or jewelry. Keep your hair, clothing and gloves away from moving parts. Loose clothes, jewelry or long hair can be caught in moving parts.
- If devices are provided for the connection of dust extraction and collection facilities, ensure these are connected and properly used. Use of dust collection can reduce dust-related hazards.

Power Tool Use and Care

- Do not force the power tool. Use the correct power tool for your application. The correct power tool will do the job better and safer at the rate for which it was designed.
- Do not use the power tool if the switch does not turn it on and off. Any power tool that cannot be controlled with the switch is dangerous and must be repaired.
- Disconnect the plug from the power source and/or remove the battery pack, if detachable, from the power tool before making any adjustments, changing accessories, or storing power tools. Such preventive safety measures reduce the risk of starting the power tool accidentally.
- Store idle power tools out of the reach of children and do not allow persons unfamiliar with the power tool or these instructions to operate the power tool. Power tools are dangerous in the hands of untrained users.
- Maintain power tools and accessories. Check for misalignment or binding of moving parts, breakage of parts and any other condition that may affect the power tool operation. If damaged, have the power tool repaired before use. Many accidents are caused by poorly maintained power tools.
- Keep cutting tools sharp and clean. Properly maintained cutting tools with sharp cutting edges are less likely to bind and are easier to control.
- Use the power tool, accessories and tool bits etc. in accordance with these instructions, taking into account the working conditions and the work to be performed. Use of the power tool for operations different from those intended could result in a hazardous situation.

Service

- Have your power tool serviced by a qualified repair person using only identical replacement parts. This will ensure that the safety of the power tool is maintained.

Safety Instructions for all Saws

Cutting Procedures

 **DANGER** Keep hands away from cutting area and the blade. Keep your second hand on auxiliary handle, or motor housing. If both hands are holding the saw, they cannot be cut by the blade.

- Do not reach underneath the workpiece. The guard cannot protect you from the blade below the workpiece.
- Adjust the cutting depth to the thickness of the workpiece. Less than a full tooth of the blade teeth should be visible below the workpiece.
- Never hold the workpiece in your hands or across your leg while cutting. Secure the workpiece to a stable platform. It is important to support the work properly to minimize body exposure, blade binding, or loss of control.
- Hold the power tool by insulated gripping surfaces, when performing an operation where the cutting tool may contact hidden wiring or its own cord. Contact with a “live” wire will also make exposed metal parts of the power tool “live” and could give the operator an electric shock.
- When ripping, always use a rip fence or straight edge guide. This improves the accuracy of cut and reduces the chance of blade binding.
- Always use blades with correct size and shape (diamond versus round) of arbor holes. Blades that do not match the mounting hardware of the saw will run off-center, causing loss of control.

- Never use damaged or incorrect blade washers or bolt. The blade washers and bolt were specially designed for your saw, for optimum performance and safety of operation.

Kickback Causes and Related Warnings

- Kickback is a sudden reaction to a pinched, bound, or misaligned saw blade, causing an uncontrolled saw to lift up and out of the workpiece toward the operator.
- When the blade is pinched or jammed tightly by the kerf closing down, the blade stalls and the motor reaction drives the unit rapidly back toward the operator.
- If the blade becomes twisted or misaligned in the cut, the teeth at the back edge of the blade can dig into the top surface of the wood causing the blade to climb out of the kerf and jump back toward operator.
- Kickback is the result of saw misuse and/or incorrect operating procedures or conditions and can be avoided by taking proper precautions as given below.
- Maintain a firm grip with both hands on the saw and position your arms to resist kickback forces. Position your body to either side of the blade, but not in line with the blade. Kickback could cause the saw to jump backwards, but kickback forces can be controlled by the operator, if proper precautions are taken.
- When the blade is binding, or when interrupting a cut for any reason, release the trigger and hold the saw motionless in the material until the blade comes to a complete stop. Never attempt to remove the saw from the work or pull the saw backward while the blade is in motion or kickback may occur. Investigate and take corrective actions to eliminate the cause of blade binding.
- When restarting a saw in the workpiece, center the saw blade in the kerf so that the saw teeth are not engaged in the material. If a saw blade binds, it may walk up or kickback from the workpiece as the saw is restarted.
- Support large panels to minimize the risk of blade pinching and kickback. Large panels tend to sag under their own weight. Supports must be placed under the panel on both sides, near the line of cut and near the edge of the panel.
- Do not use dull or damaged blades. Unsharpened or improperly set blades produce narrow kerf causing excessive friction, blade binding and kickback.

- Blade-depth and bevel-adjusting locking levers must be tight and secure before making the cut. If blade adjustment shifts while cutting, it may cause binding and kickback.
- Use extra caution when sawing into existing walls or other blind areas. The protruding blade may cut objects that can cause kickback.

Safety Instructions for Plunge-type Saws

Guard Function

- Check the guard for proper closing before each use. Do not operate the saw if the guard does not move freely and enclose the blade instantly. Never clamp or tie the guard so that the blade is exposed. If the saw is accidentally dropped, the guard may be bent. Check to make sure that the guard moves freely and does not touch the blade or any other part, in all angles and depths of cut.
- Check the operation and condition of the guard return spring. If the guard and the spring are not operating properly, they must be serviced before use. The guard may operate sluggishly due to damaged parts, gummy deposits, or a build-up of debris.
- Assure that the base plate of the saw will not shift while performing a plunge cut. Blade shifting sideways will cause binding and likely kick back.
- Always observe that the guard is covering the blade before placing the saw down on bench or floor. An unprotected, coasting blade will cause the saw to walk backwards, cutting whatever is in its path. Be aware of the time it takes for the blade to stop after the switch is released.

Riving Knife Function

- Use the appropriate saw blade for the riving knife. For the riving knife to function, the body of the blade must be thinner than the riving knife and the cutting width of the blade must be wider than the thickness of the riving knife.
- Adjust the riving knife as described in this instruction manual. Incorrect spacing, positioning and alignment can make the riving knife ineffective in preventing kickback.
- For the riving knife to work, it must be engaged in the workpiece. The riving knife is ineffective in preventing kickback during short cuts.













- Do not operate the saw if the riving knife is bent. Even a light interference can slow the closing rate of a guard.

Safety Instructions Specific to Using the ACS Saw and Guide Kit

- Do not allow familiarity gained from frequent use of your tools to replace safe work practices. A moment of carelessness is sufficient to cause serious injury.
- This saw features anti-kickback and other built-in safety features that only operate with the saw properly mounted on the guide track. It is always recommended to use this saw with the track for cutting. To use without the track, refer to **Safety Instructions for all Saws** on page 3.
- Never operate the saw with the splinter guard removed. Removing the splinter guard exposes a portion of the blade to possible hand contact.
- Check saw plunge action before each use. Do not operate if saw does not freely plunge and return to full up position. Never clamp or tie the saw in plunge position.
- If saw is dropped, plunge action may be damaged. Plunge and return saw to full-up position. Make sure it moves freely and blade does not touch the housing or any other part, in all angles and depths of cut.
- This saw is equipped with a riving knife that automatically extends with the blade. The riving knife is an important part of anti-kickback protection. Periodically check to make sure it operates freely. If you have any concerns about the operation of the riving knife, do not use the saw.
- For all cuts, position the workpiece under the guide track with the waste to the outside.
- For cuts less than 4" wide, support the guide track with scrap the same thickness as the workpiece.
- Avoid awkward hand positions where a sudden slip could cause contact with the cutting blade.
- Always keep hands clear of the cut path of the cutting blade while cutting. Failure to do so can result in serious injury.
- Keep hands away from cutting area and blade. Keep your second hand on the forward grip. If both hands are holding the saw, they cannot be cut by the blade.
- Hold tool by insulated gripping surfaces when performing an operation where the cutting tool may contact hidden wiring or its own cord. Contact with an energized wire will also energize exposed metal parts of the tool and shock the operator.
- Keep your body positioned to either side of the saw blade, and not in line with the saw blade. Kickback could cause the saw to jump backwards. (See **Kickback Causes and Related Warnings** on page 4)
- Always observe that the blade is fully retracted into the housing before placing saw down on bench or floor. An unprotected, coasting blade will cause the saw to move backwards, cutting whatever is in its path. Be aware of the time it takes for the blade to stop after switch is released.
- Only use a 6-1/2" [165 mm]-diameter blade with a 20 mm round arbor hole. Blades that do not match the mounting hardware of the saw will run eccentrically, causing loss of control.
- Only use a blade rated for a minimum of 7,000 rpm.
- Only use a blade with blade body thickness less than 2.0 mm and tooth set of the blade greater than 2.0 mm.
- Never use a damaged or incorrect blade washer or bolt. The blade washer and bolt are designed specifically for optimum performance and safe operation of this saw.
- Do not use an abrasive wheel in this saw.
- This saw is intended for cutting wood and wood products only. Do not cut metal, masonry, glass, masonry-type planking, cement board, tile or plastic with this saw.
- Ensure that the riving knife is adjusted so that the distance between the riving knife and the rim of the blade is not more than 5 mm, and the rim of the blade does not extend more than 5 mm beyond the lowest edge of the riving knife.
- Dust bag or dust collection hose should be installed on the dust port prior to operation.

Terms and Definitions

The label on the saw may include the symbols below. The symbols and their definitions are as follows:

	Safety alert symbol
V	Volts
Hz	Hertz
A	Amperes
W	Watts
	Direct current
	Alternating current
	Alternating or direct current
	Class I construction (grounded)
	Class II tool (double insulated)
	Earthing terminal
min	Minutes
/min	Revolutions or reciprocations per minute
BPM	Beats per minute
RPM	Revolutions per minute
n_0	No load speed
	Read the instructions
	Wear eye and ear protection
	Keep hands & body away from and to the side of the blade. Contact with blade will result in serious injury.
	Blade change mode
	Cut mode

Kreg® PCS6512 plunge saw motor specifications

120V ~ 60 Hz 12A

n_0 = 6,000/min

Guidelines for extension cord use

Extension cords are only to be used for temporary purposes. They do not replace the need for installation of outlets and proper wiring where necessary.

In your work area:

- Extension cords with an equipment grounding conductor must be used at all times.
- Extension cords must be protected from damage, and not run through doorways or windows where the doors or windows can close, causing damage to the cord.
- Extension cords must be a minimum of 16 AWG and be rated for the equipment in use.
- Extension cords must be periodically inspected to ensure that the insulation and conductivity of the wires are not compromised.
- Extension cords should not be run through water or allowed to have connections that may be exposed to accumulated water.

Nameplate Amperes @ 120 V	Extension Cord Length					
	25'	50'	75'	100'	150'	200'
	Recommended Wire Gauge					
0 – 5	16	16	16	14	12	12
5.1 – 8	16	16	14	12	10	NR
8.1 – 12	14	14	12	10	NR	NR
12.1 – 16	12	12	NR	NR	NR	NR

NR – Not Recommended

ACS-SAWBB

⚠ WARNING This product can expose you to chemicals including Acrylonitrile and other chemicals, which are known to the State of California to cause cancer and reproductive harm. For more information go to www.P65Warnings.ca.gov.

⚠ WARNING Drilling, sawing, sanding or machining wood products can expose you to wood dust, a substance known to the State of California to cause cancer. Avoid inhaling wood dust or use a dust mask or other safeguards for personal protection. For more information go to www.P65Warnings.ca.gov/wood.

Guide Tracks

⚠ WARNING This product can expose you to chemicals including Carbon 1333-86-4, which are known to the State of California to cause cancer. For more information go to www.P65Warnings.ca.gov.

Pre-Assembly

Review this section before you begin. Ensure you have all tools/materials on hand and compare the package with the items listed in the Hardware Included and Product Description sections. If any item appears missing or lost, do not use this product. Contact Kreg Customer Experience or return product to place of purchase.

Guide Track Components

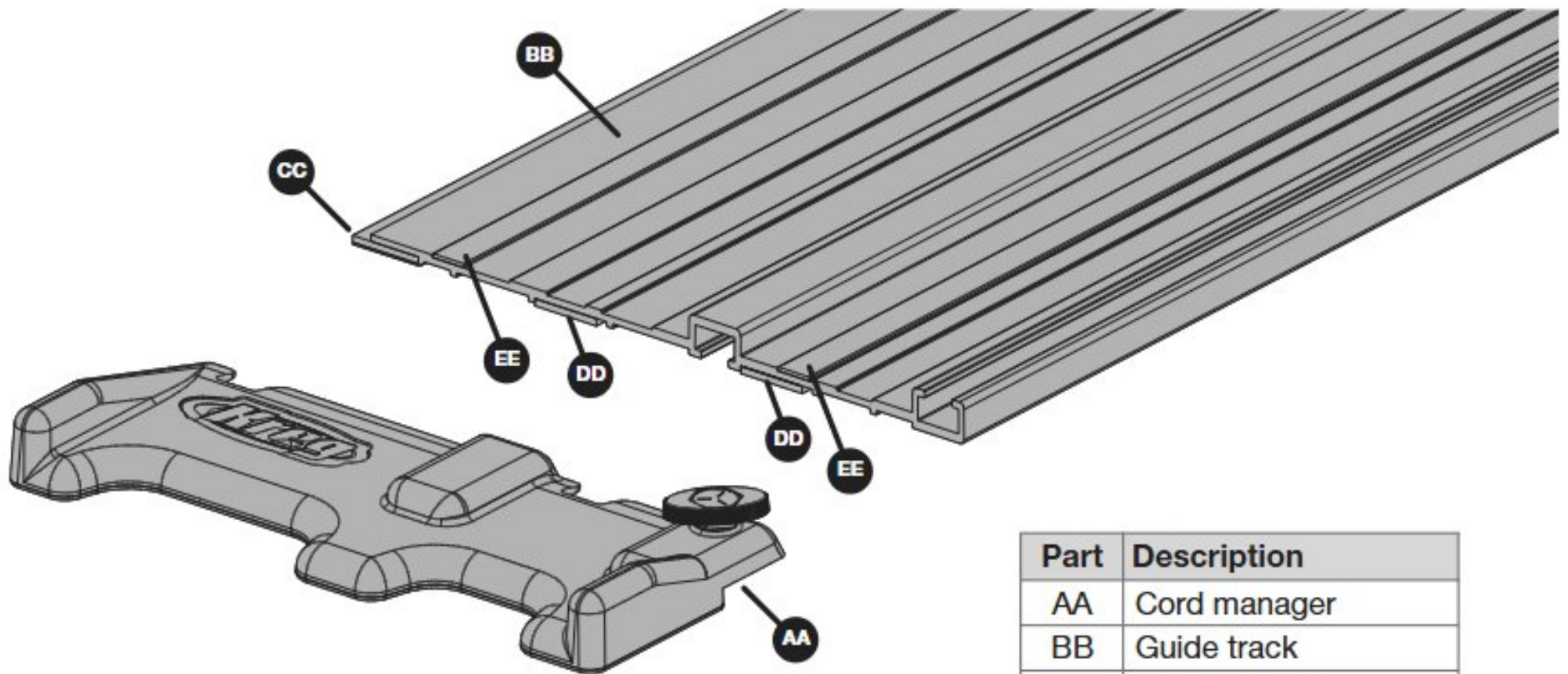

Part	Description
AA	Cord manager
BB	Guide track
CC	Anti-chip strip
DD	Anti-slip strips
EE	Glide strips

Guide Track Connector Components

Guide tracks can be joined with guide track connectors for making longer cuts.

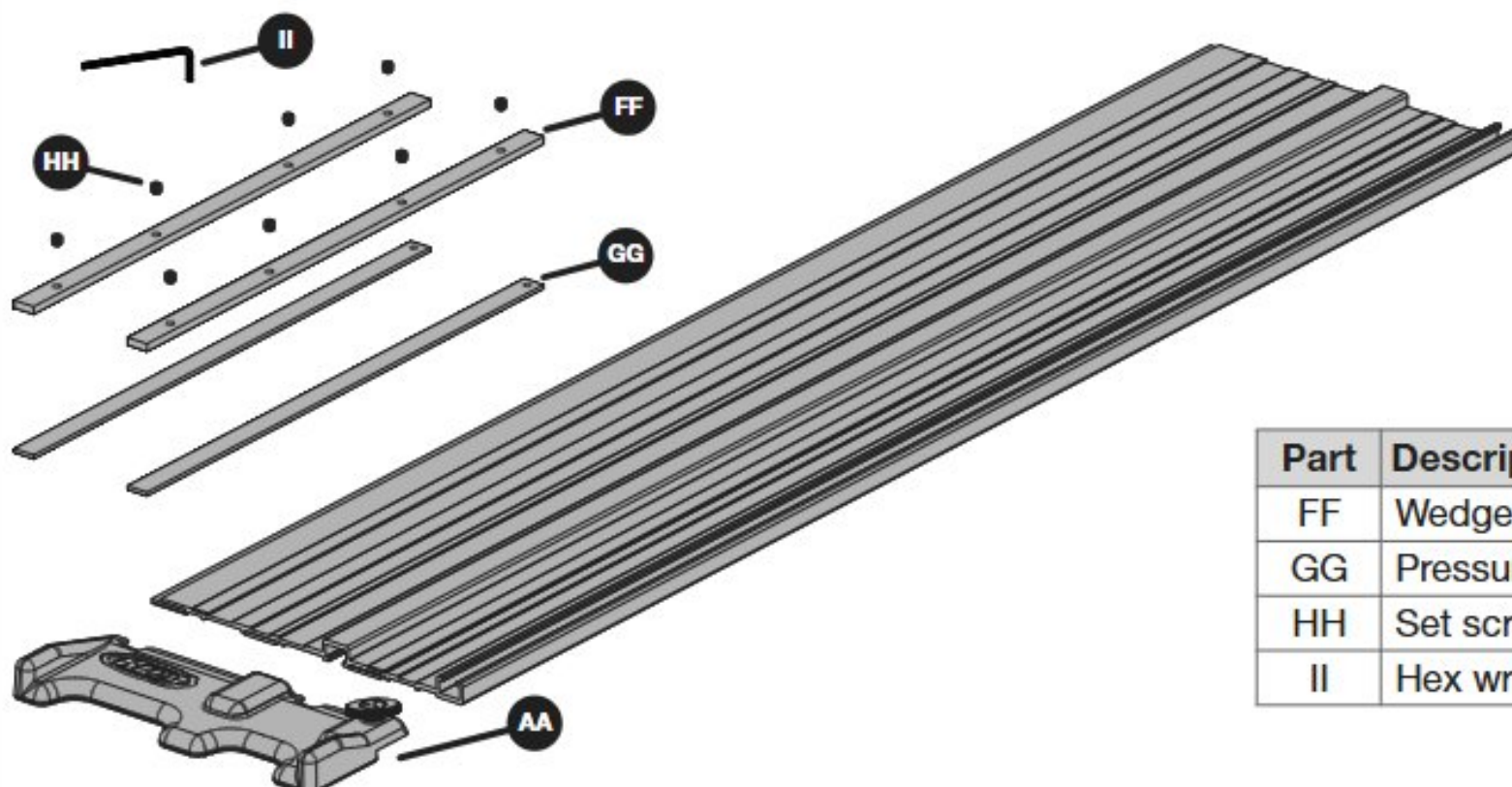

Part	Description
FF	Wedges with threaded holes
GG	Pressure plates
HH	Set screws
II	Hex wrench

Joining Guide Track Sections

- With one guide track (BB) right side up, slide a pair of wedges (FF) and pressure plates (GG) half way into the T-slot of the track.
- Thread in and tighten the two set screws (HH) that are in the guide track (BB) using the hex wrench (II).

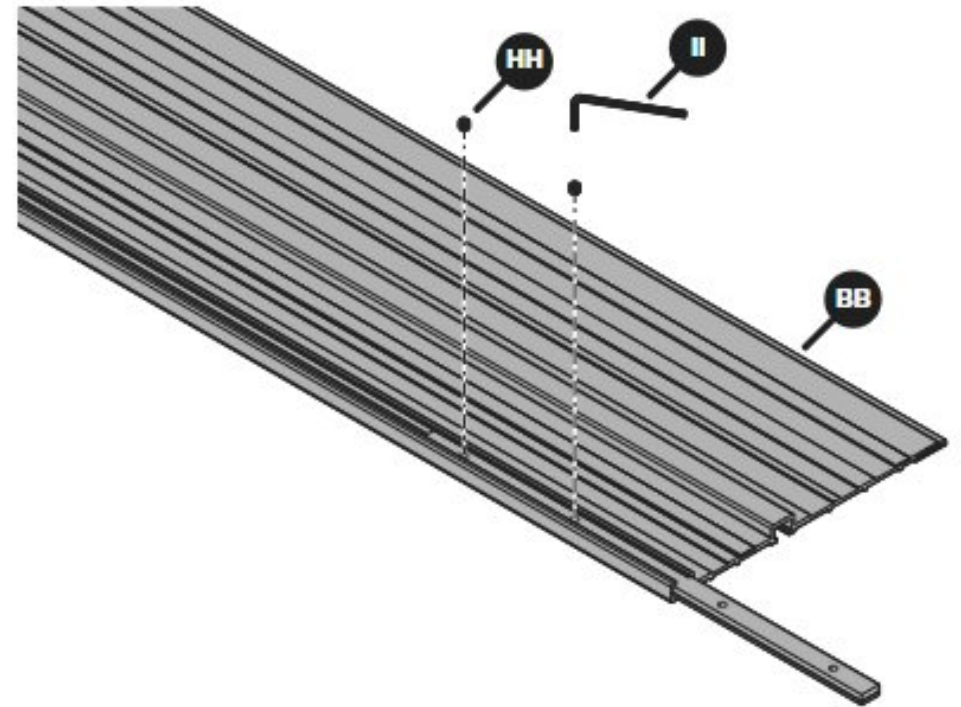
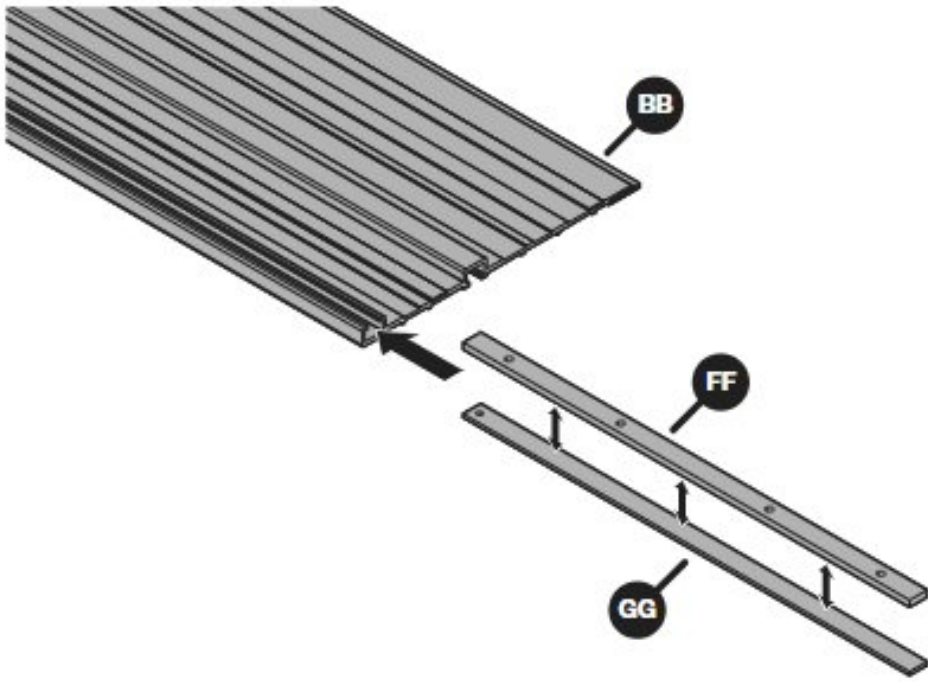

- Turn the guide track (BB) upside down and slide a second pair of wedges (FF) and pressure plates (GG) half way into the other T-slot of the guide track (BB).
- Thread in and tighten the two set screws (HH) that are in the guide track (BB) using the hex wrench (II).

IMPORTANT Both set screws must be turned the same amount in the same direction.

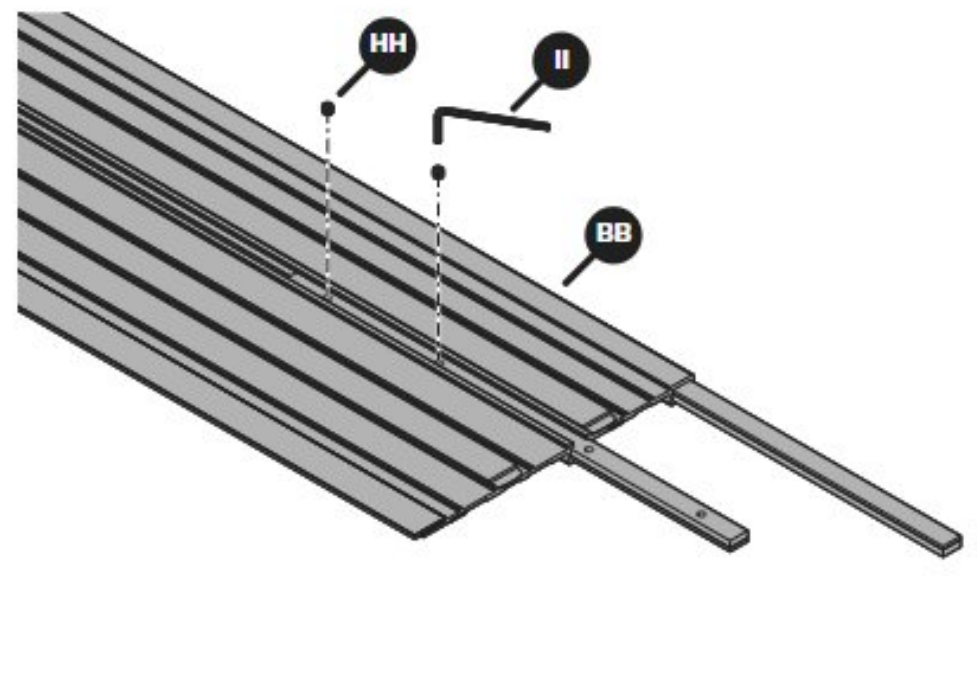
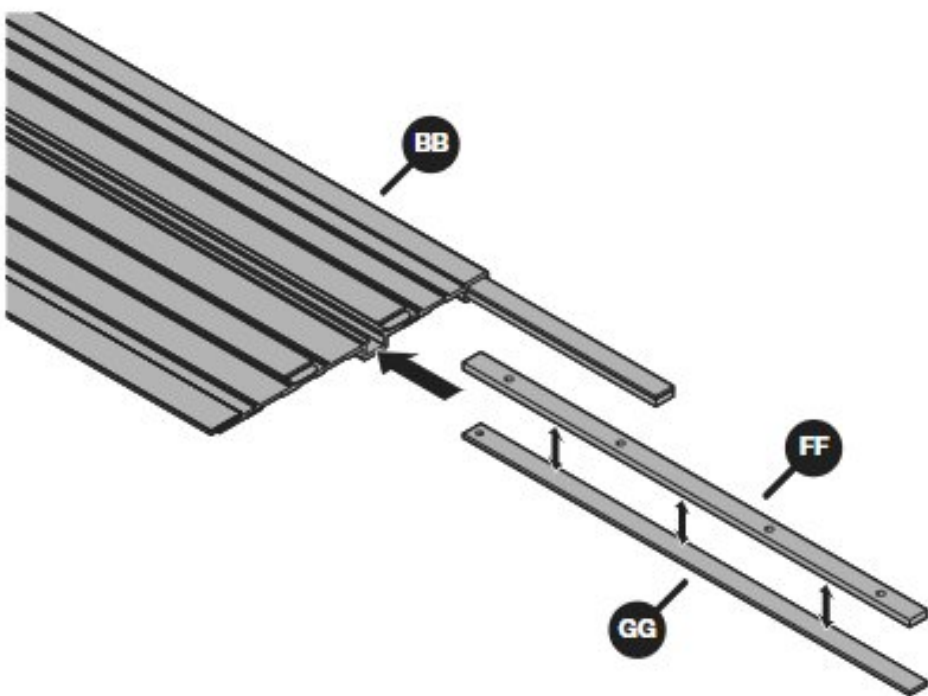

Joining Guide Track Sections (continued)

- e. Slide the second guide track (BB) onto the protruding wedges (FF) and pressure plates (GG).
- f. Align the guide tracks (BB) with a straight edge (1).
- g. Thread in and tighten the remaining set screws (HH) using the hex wrench (II).
- h. Turn the guide tracks (BB) right side up and align the edges with a straight edge (1).
- i. Thread in and tighten the remaining set screws (HH) with the hex wrench (II).

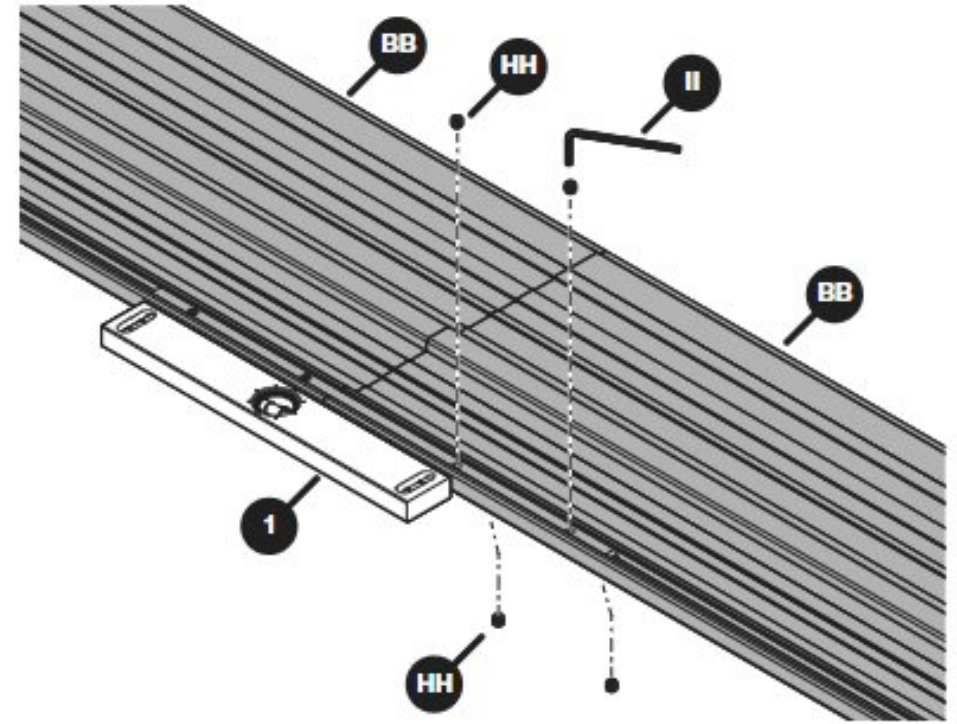
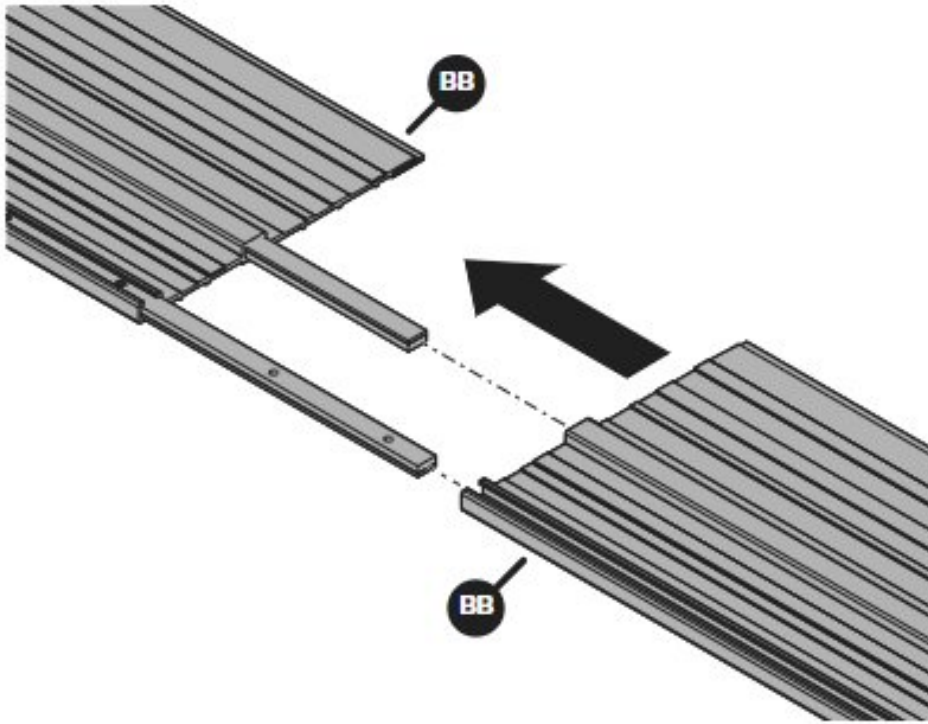

Saw Components

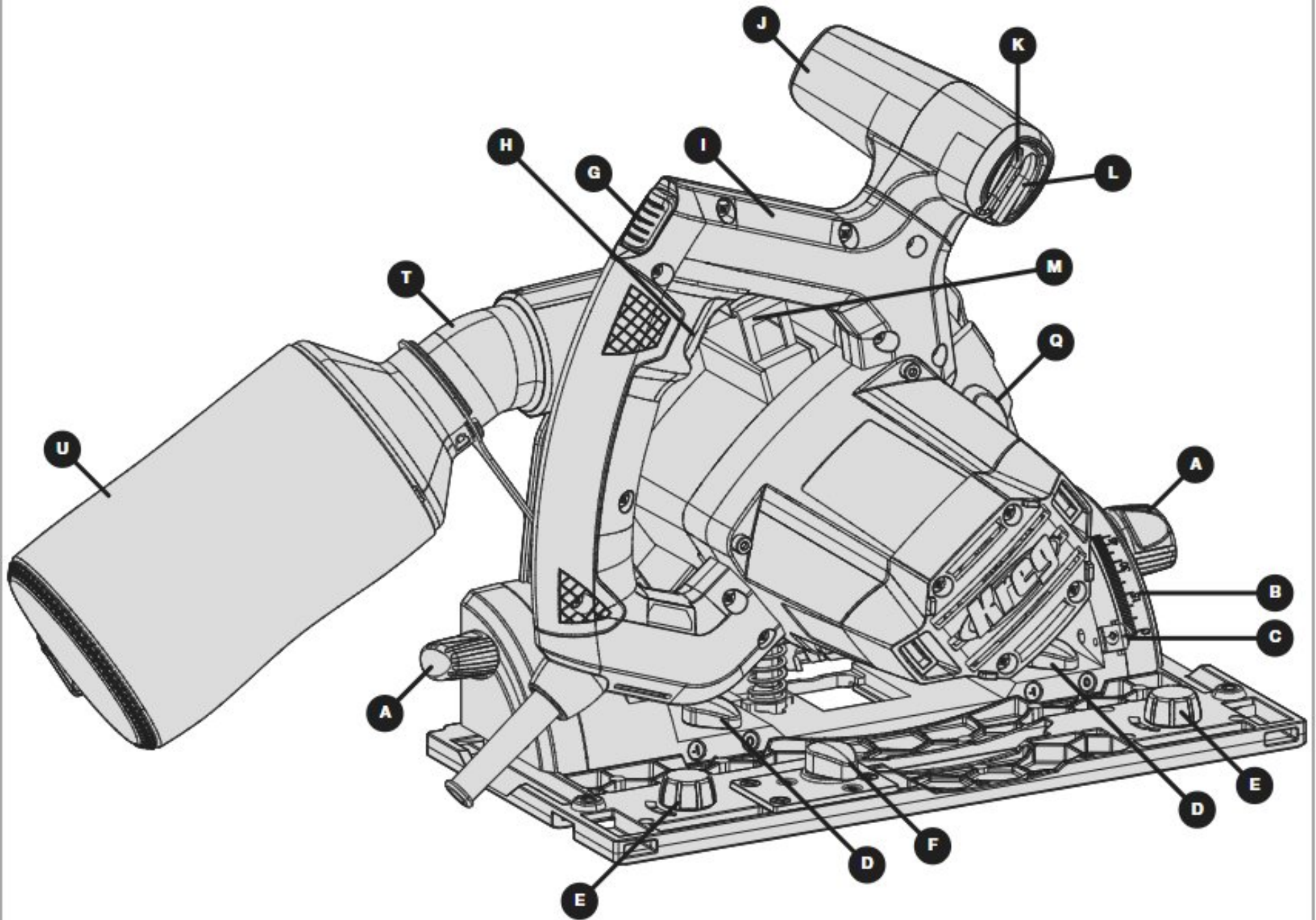

Part	Description
A	Bevel locks
B	Bevel scale
C	Bevel indicator
D	-1° override locks
E	Track adjustment knobs
F	Anti-kickback control
G	Switch interlock
H	Switch
I	Switch handle
J	Forward grip

Part	Description
K	Small hex wrench (3 mm)
L	Large hex wrench (5 mm)
M	Arbor Lock
N	Bevel-adjustment set screws
O	Toe-in adjustment screws
P	Blade mode selector
Q	Cut-depth stop
R	Cut-depth scale
S	47° override lock
T	Dust port

Part	Description
U	Dust bag
V	Riving knife
W	Blade
X	Splinter guard
Y	Splinter guard screw
Z	Blade-rotation indicator
YY	Arbor screw
ZZ	Flange washer

Saw Components (continued)

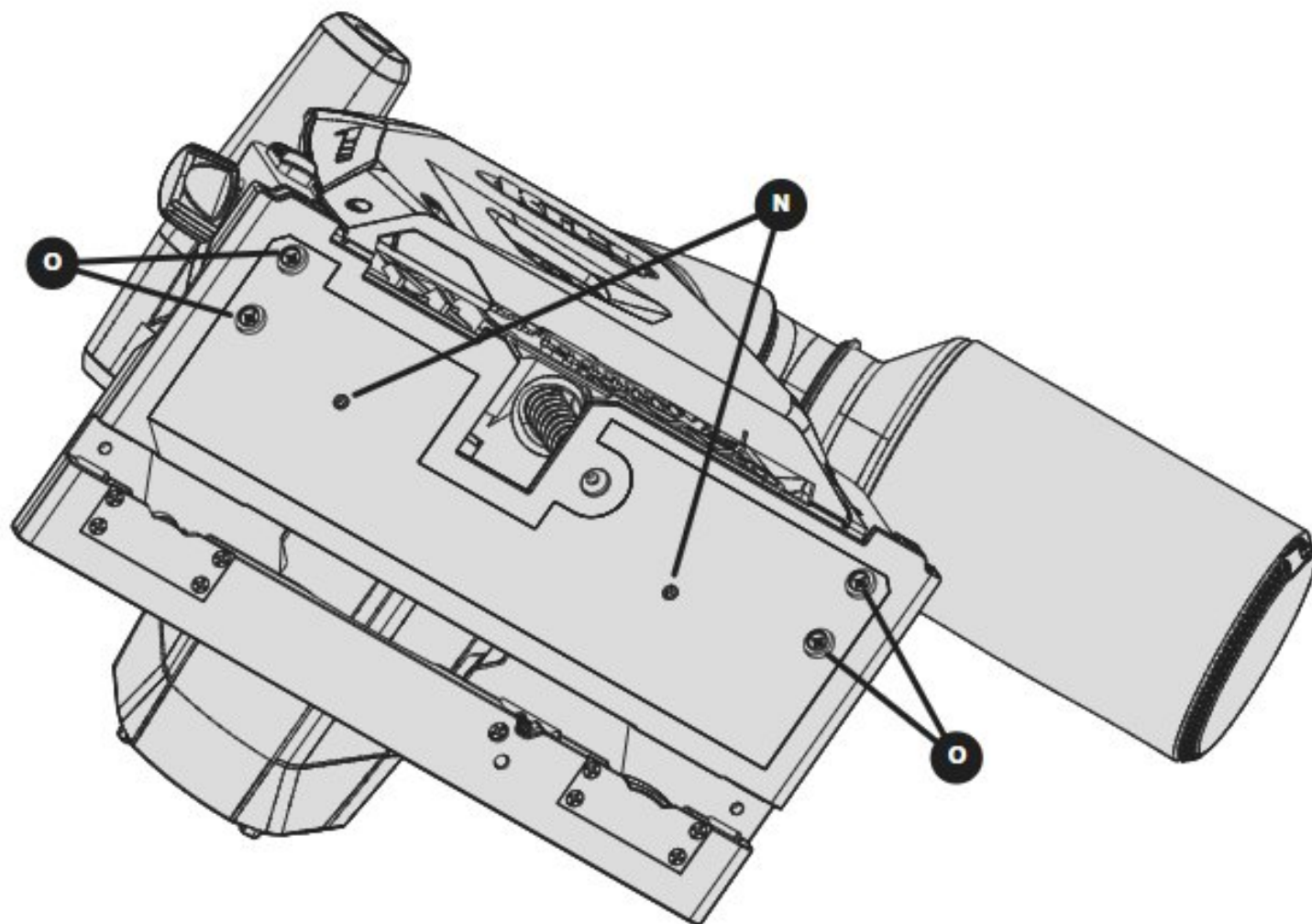
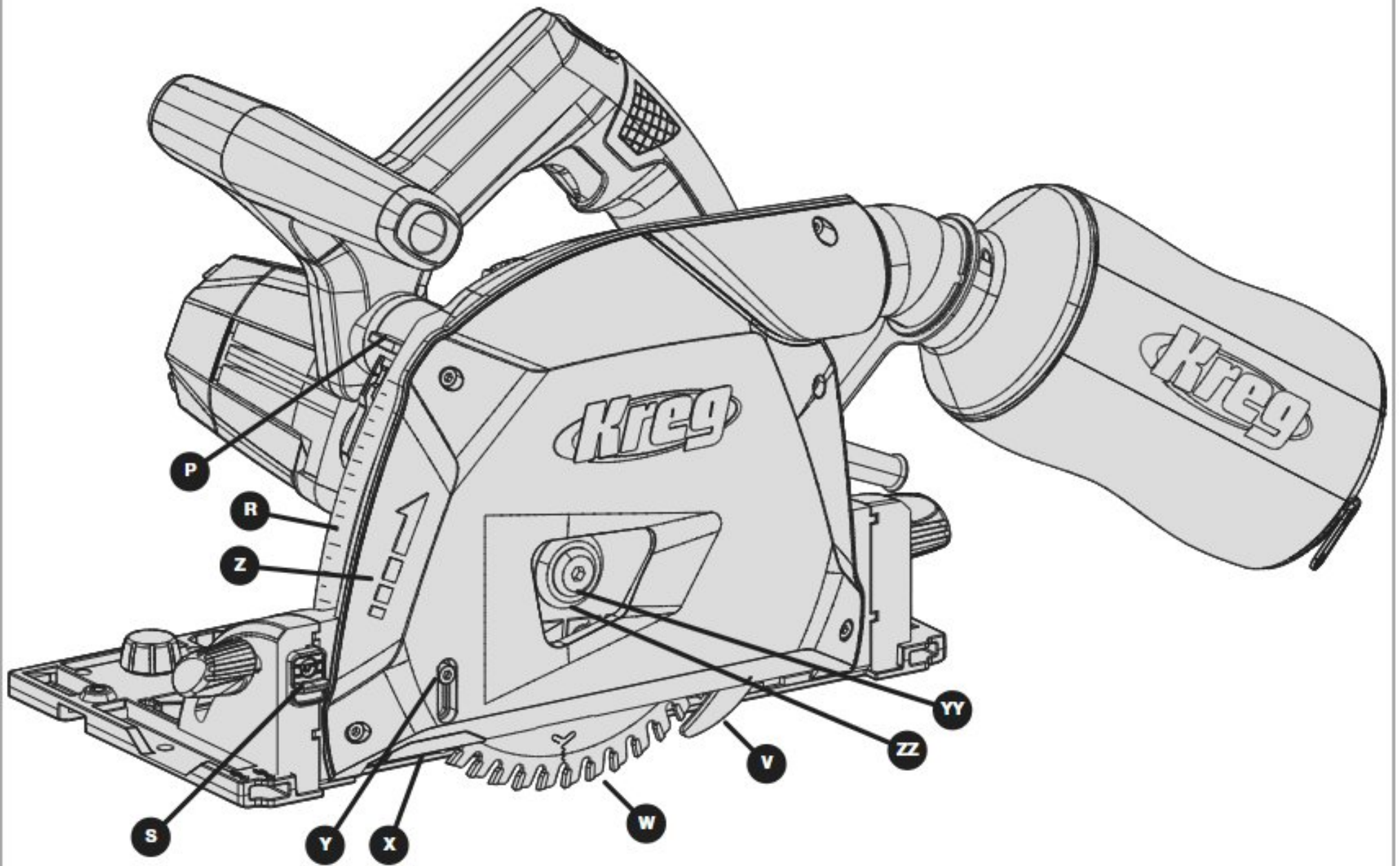

1 Calibrate the Bevel Scale

WARNING Disconnect saw from power before making any adjustments.

IMPORTANT The saw blade is aligned perpendicular to the saw base and the bevel indicator set at 0° at the factory. To ensure accurate cuts, check the alignment and the position of the bevel indicator as indicated below.

- Verify that the -1° bevel overrides (D) are in the 0° position. (See **Bevel Cuts** on page 22)
- Adjust the cut-depth stop (Q) to full depth.
- Loosen the front and rear bevel locks (A).
- Remove splinter guard (X) from blade housing, then press the switch interlock button (G) and plunge the saw to full depth and hold.
- Check the blade-to-base angle with a square (1).
- Adjust the angle by turning the bevel-adjustment set screws (N).

IMPORTANT Both set screws must be turned the same amount in the same direction.

- Tighten the front and rear bevel locks (A).
- Set the bevel indicator (C) to the zero mark and reinstall the splinter guard (X).

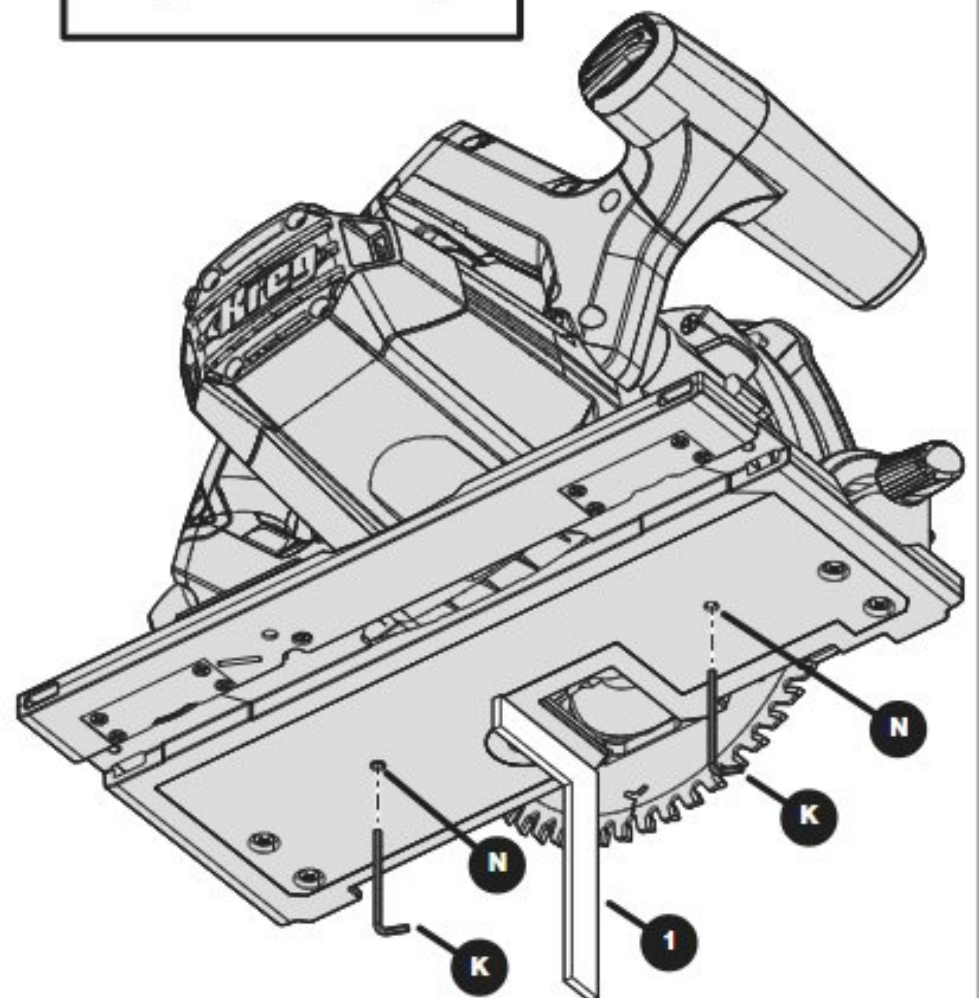
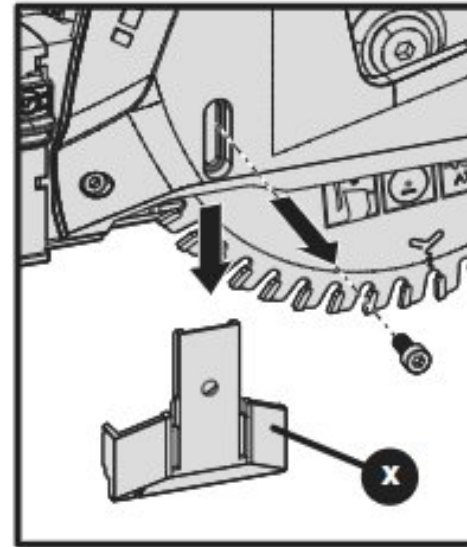
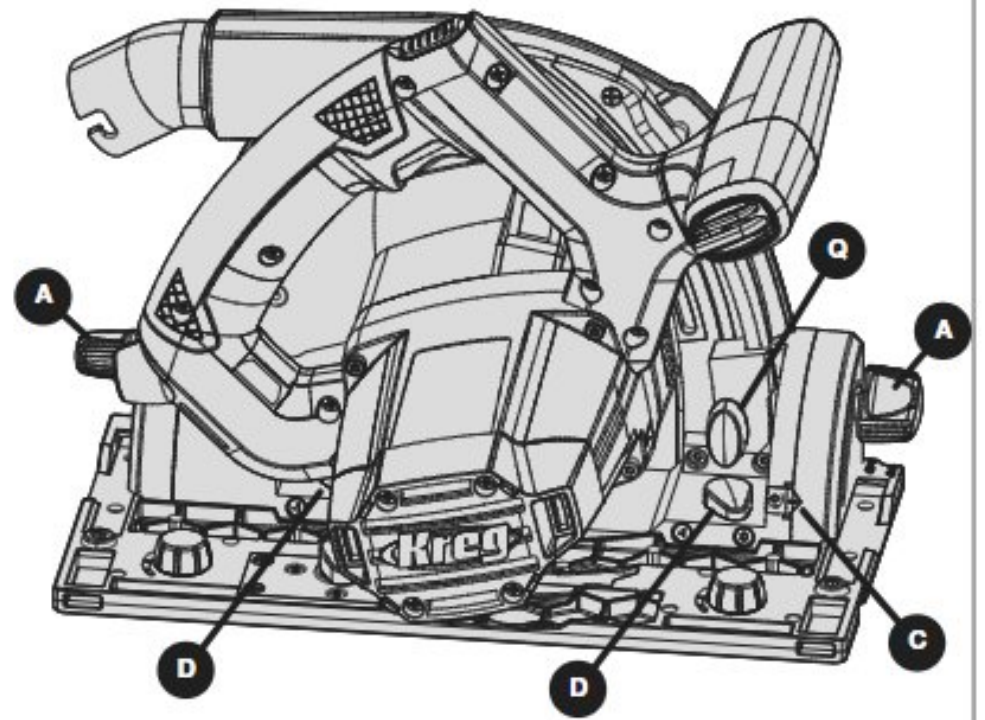

2 Cord Manager

Installed on the infeed end of the guide track (BB), the cord manager (AA) prevents the power cord and vacuum hose from catching on the end of the track.

- Install the hex bolt (1), knob (2), and square nut (3) on the cord manager (AA).
- Slide the assembly onto the infeed end of the guide track (BB), slipping the square nut into the track T-slot.
- Tighten the knob (2).

IMPORTANT The cord manager may have to be temporarily removed when installing other accessories.

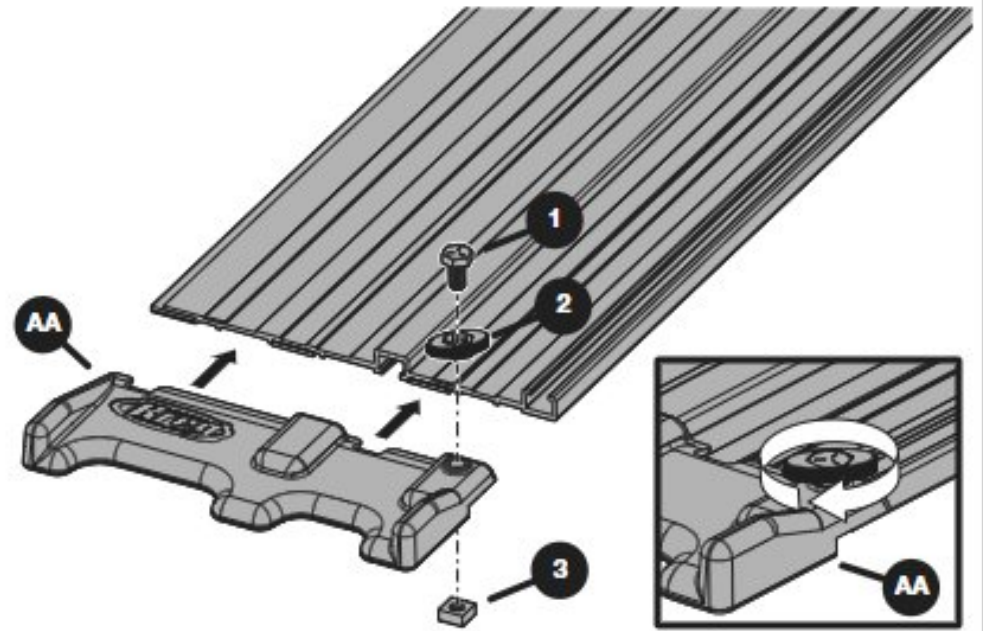

3 Dust Collection

- Align the large lug on dust bag (U) with the large slot on the dust port (T), push on the dust bag (U) and twist to lock. The 1.575" (40 mm) outside diameter, 1.378" (35 mm) inside diameter dust port (T) also accepts most common vacuum hoses.
- Rotate the port to orient the dust bag (U) or vacuum hose to the desired position.
- To empty, remove the dust bag (U) and unzip the end.

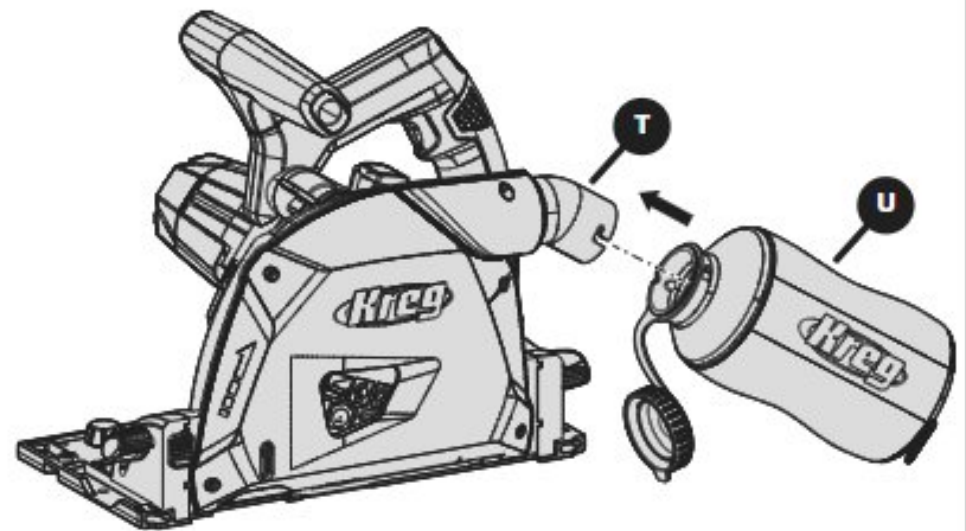

4 Adjust Tracking

- Loosen the track adjustment knobs (E).
- Place the saw on the guide track (BB). Tighten the track adjustment knobs (E) to eliminate play while allowing the saw to slide on the guide track (BB) without binding.

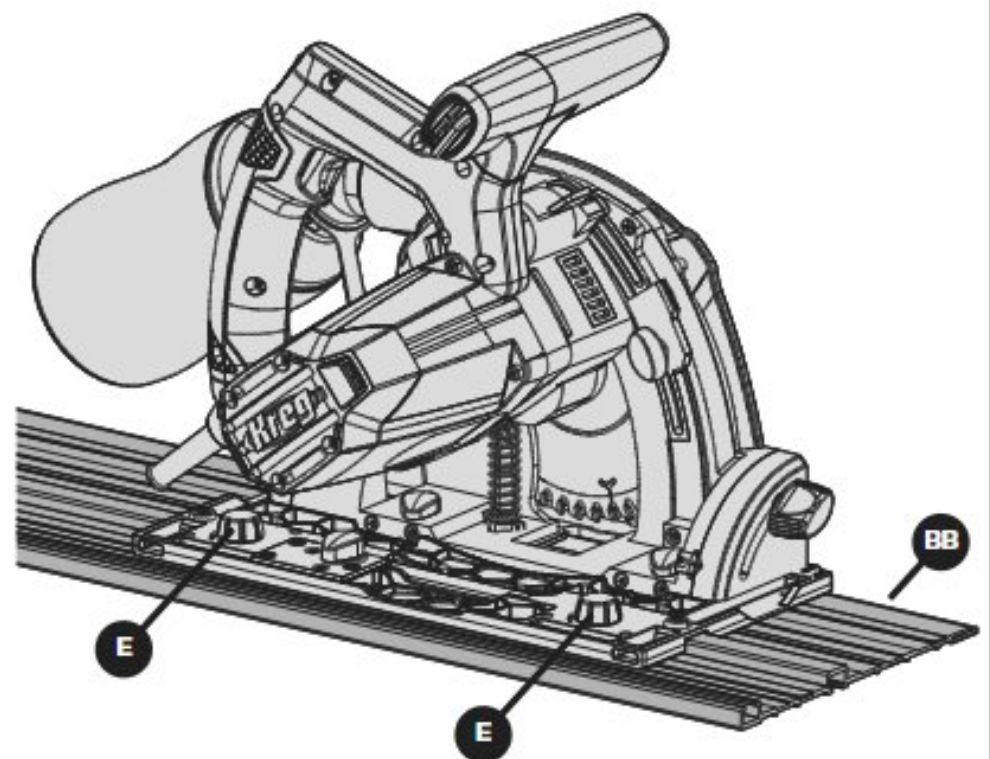

5 Trim the Anti-Chip Strip

- a. Loosen the cut-depth stop (Q), slide the stop to align the pointer with the 1/4" mark, and tighten the cut-depth stop (Q).

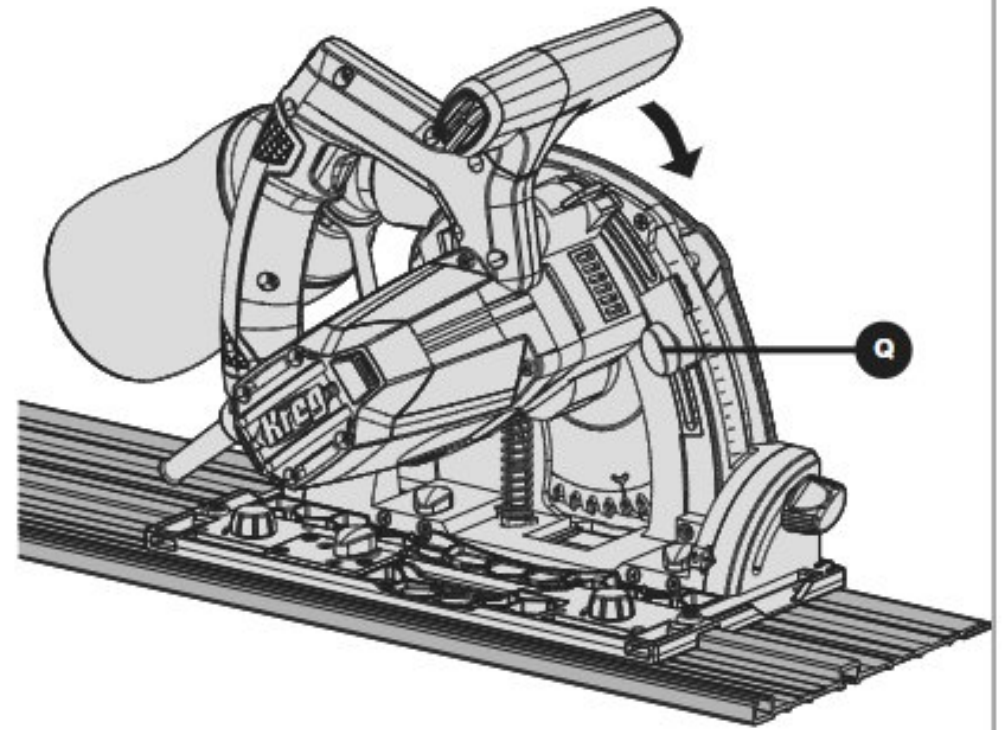

- b. Place the guide track (BB) on a scrap workpiece at least 62" (158 cm) long and 1" (25 mm) wider than the guide track (BB). Position the saw on the guide track (BB) with both track adjustment knobs (E) engaged.
- c. Loosen the splinter guard screw (Y) with the small hex wrench (K) stored in the forward grip (J) and raise the splinter guard (X) to the full-up position.

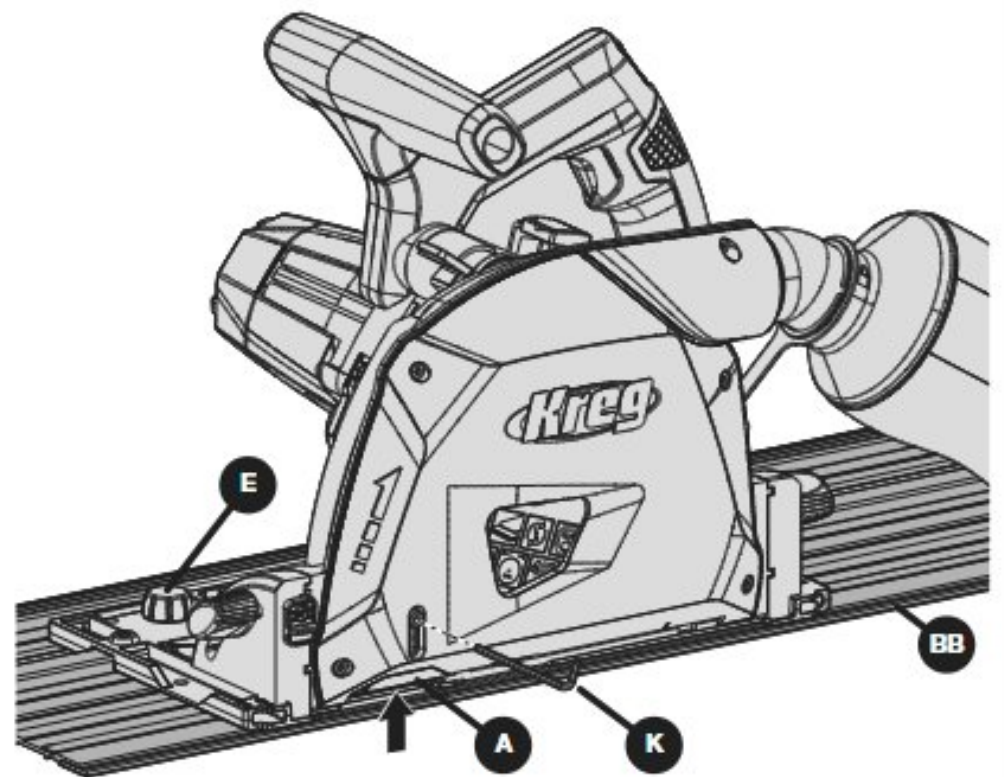

- d. Set the blade mode selector (P) to cut mode.

Cut Mode

Blade Change Mode

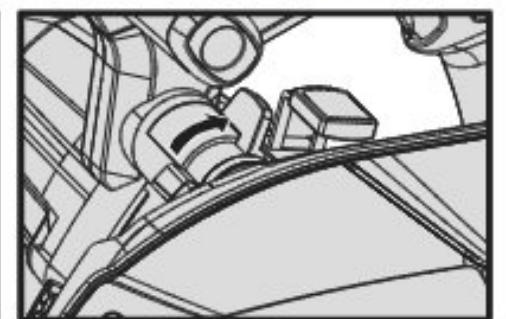
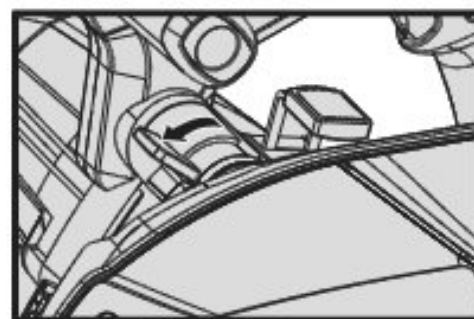

- e. Engage the anti-kickback control (F).

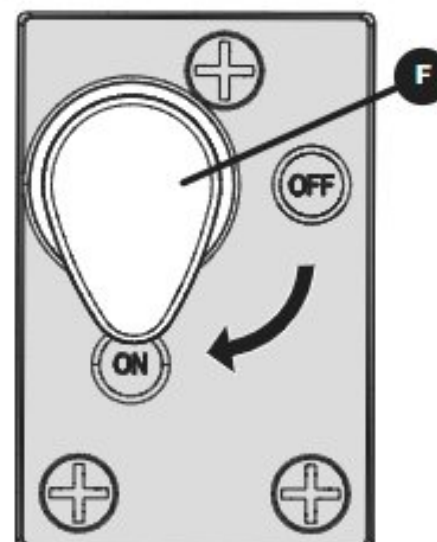

5 Trim the Anti-Chip Strip (continued)

- f. Connect the saw to power, press the switch interlock button (G), and depress the switch (H).

WARNING Always hold the saw with both hands when cutting. Keep one hand on the switch handle and the other on the forward grip.

- g. Place the saw on the track closest to the cord manger (AA), and plunge the saw to the set depth and push it along the guide track (BB).

IMPORTANT Both track adjustment knobs must engage the guide track at the start of the cut. Stop the cut before the leading track adjustment knob disengages from the guide track. A portion of the anti-chip strip at both ends of the guide track remains untrimmed.

IMPORTANT Blue chips are natural to see here as you are cutting through the anti-chip strip to give you zero clearance.

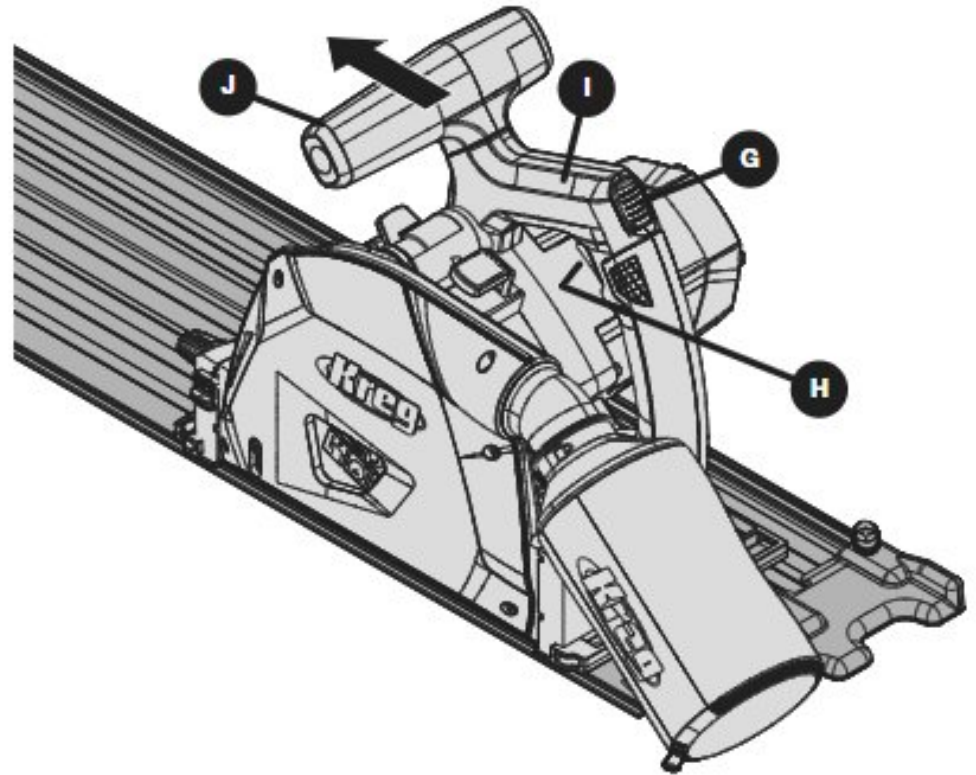

6 Trim the Splinter Guard

- a. With the guide track (BB) on the scrap workpiece, position the saw on the guide track (BB). Loosen the splinter guard screw (Y) and lower the splinter guard (X) until it contacts the workpiece, and re-tighten the splinter guard screw (Y).
- b. Turn on the saw and plunge the blade to trim and cut through the splinter guard (X) to the cutting depth.

IMPORTANT Blue chips are natural to see here as you are cutting through the splinter guard to give you zero clearance.

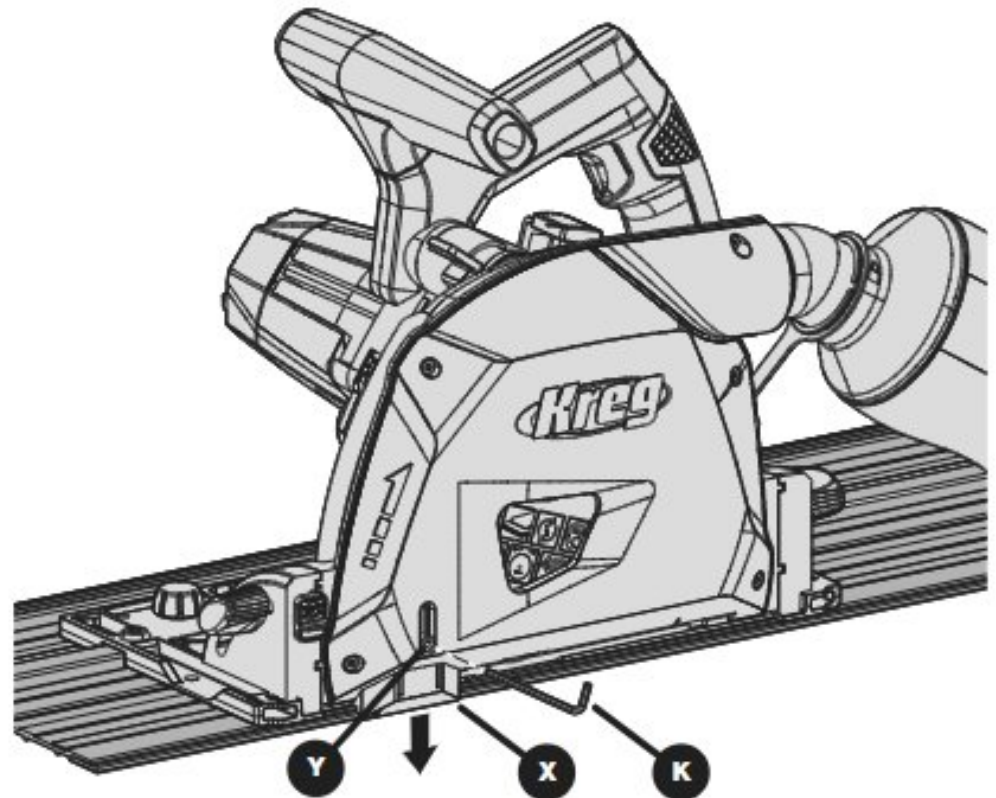

7 Toe-In Adjustment

IMPORTANT For smooth cuts, the face of the saw blade must be parallel to the edges of the saw base. This alignment is made at the factory and user adjustment, shown below, should only be necessary in rare circumstances, such as significant impact to the saw base.

- a. Set the saw to blade change mode using the blade mode selector (P) and plunge the the blade to lock into position (See **Changing the Blade** on page 18). Verify the saw-blade tooth aligns to the edge of the anti-chip strip (CC) at the front of the blade (W).

If there is a gap then proceed to step 7c.

- b. Insert a business card (1) or construction paper approximately 0.010" thick between a blade tooth and the anti-chip strip (CC) at the rear of the blade (W). If the gap is smaller than 0.010" no calibration is needed

If the gap is larger than 0.010" thick proceed to step 7c.

- c. Place the guide track (BB) on a table with the front end of the track extending off the edge of the table and with the edge of anti-chip strip (CC) of guide track (BB) overhanging the side edge of the table. This will allow for access to plunge the the saw and access to the front toe-in adjustment screws (O).

Cut Mode

Blade Change Mode

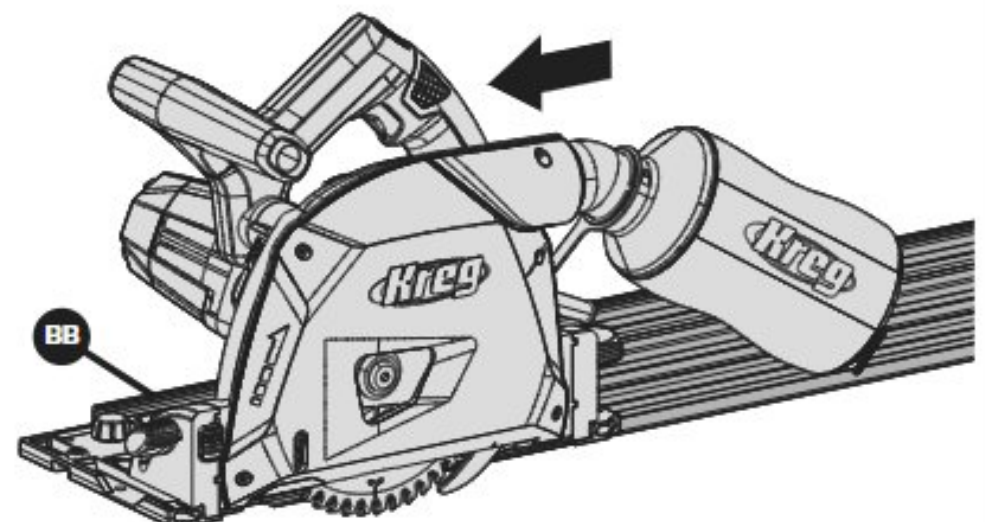
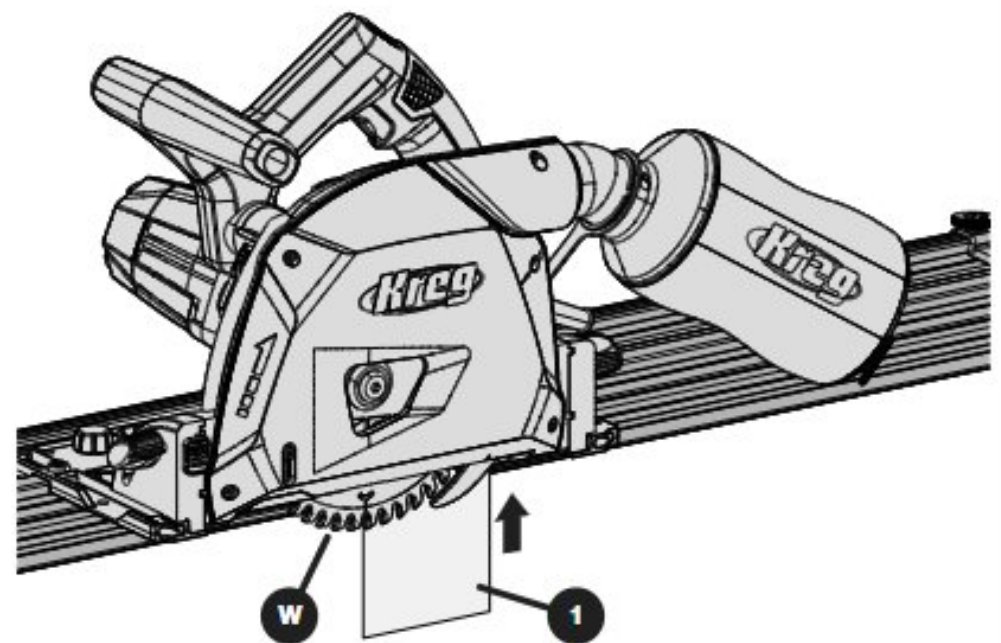
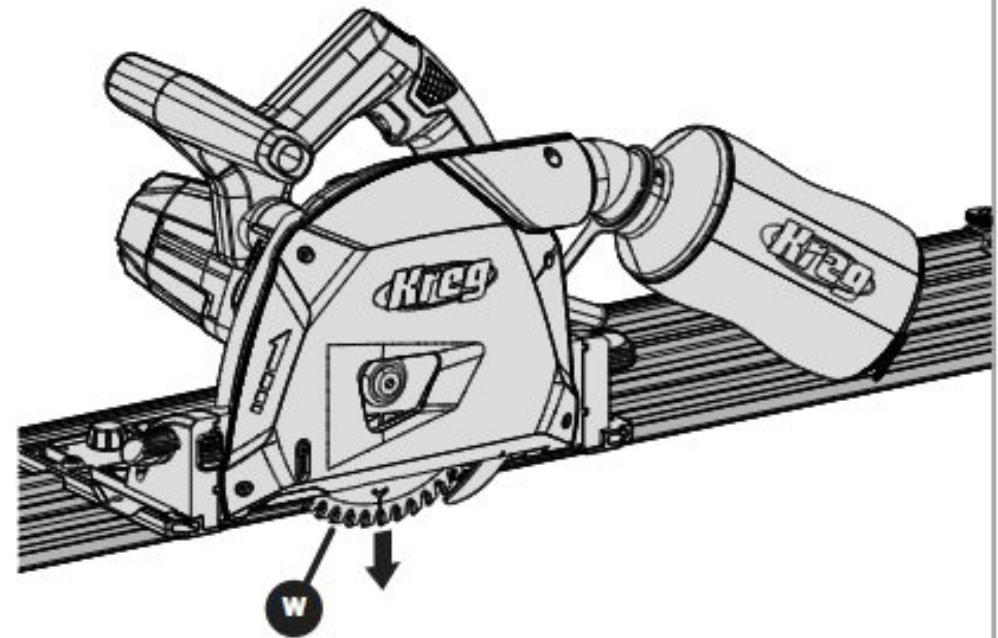
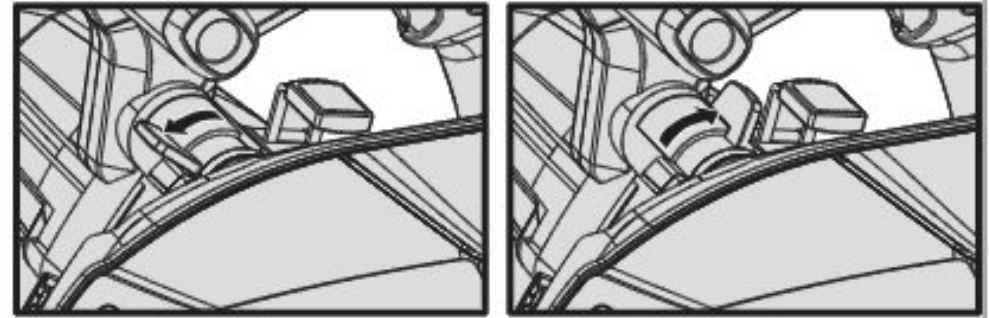

7 Toe-In Adjustment (continued)

- d. Loosen toe-in adjustment screws (O) just enough to allow side-to-side movement of the blade (W).
- e. Adjust the saw so a saw-blade tooth contacts the anti-chip strip (CC) at the front of the blade (W).
- f. Tighten the front toe-in adjustment screw (O) closest to the blade (W) to hold it in position.

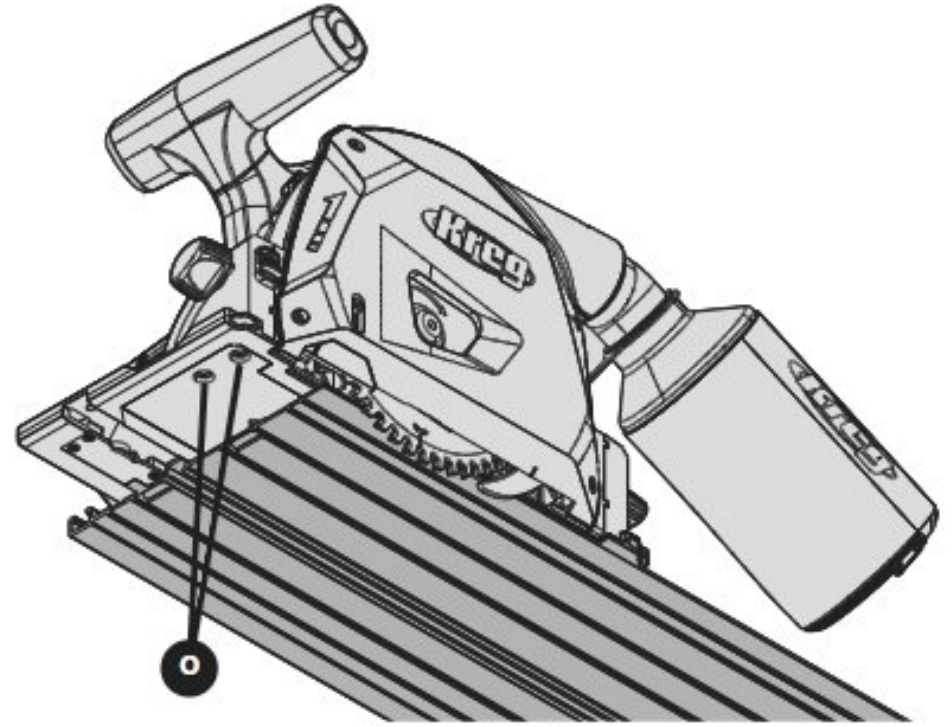

- g. Reposition the guide track (BB) on a table with the rear end of the track extending off the edge of the table and with the edge of anti-chip strip (CC) of guide track (BB) overhanging the side edge of the table. This will allow for access to plunge the saw and access to the rear toe-in adjustment screws (O). Loosen but do not remove the toe-in adjustment screws (O).
- h. Insert a business card (1) or construction paper and adjust properly to approximately 0.010 in. thick between a blade tooth and the anti-chip strip (CC) at the rear of the blade (W). This sets the proper blade toe-in.

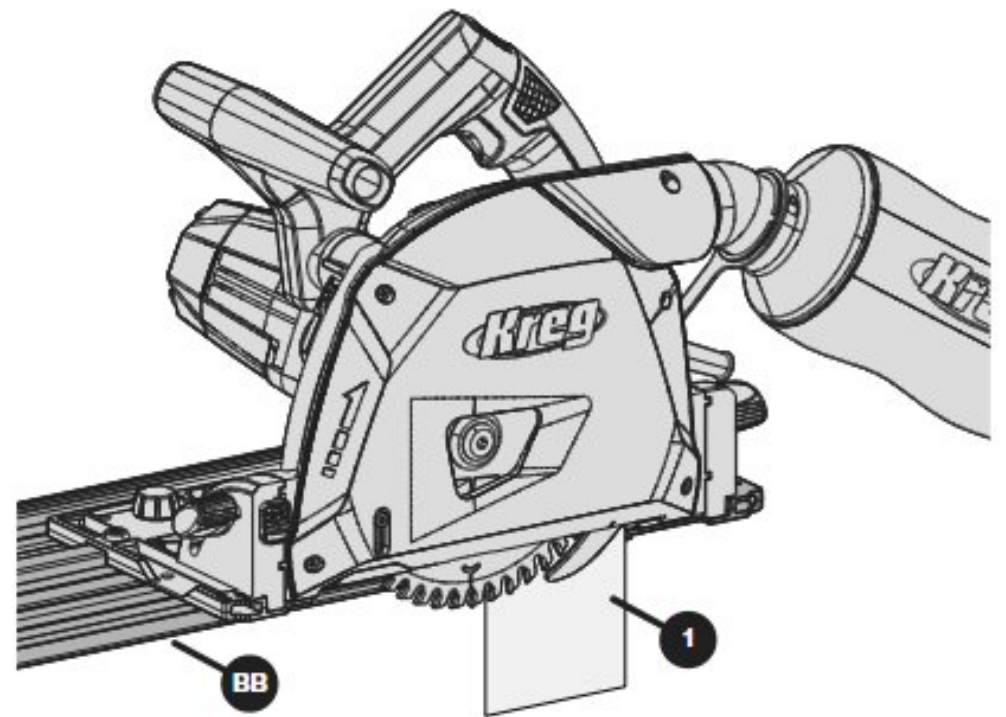

- i. Tighten both rear toe-in adjustment screws (O). Remove saw from the guide track (BB) and tighten the second front toe-in adjustment screw (O). Verify all four toe-in adjustment screws (O) are tight and that the saw is adjusted for correct toe-in.

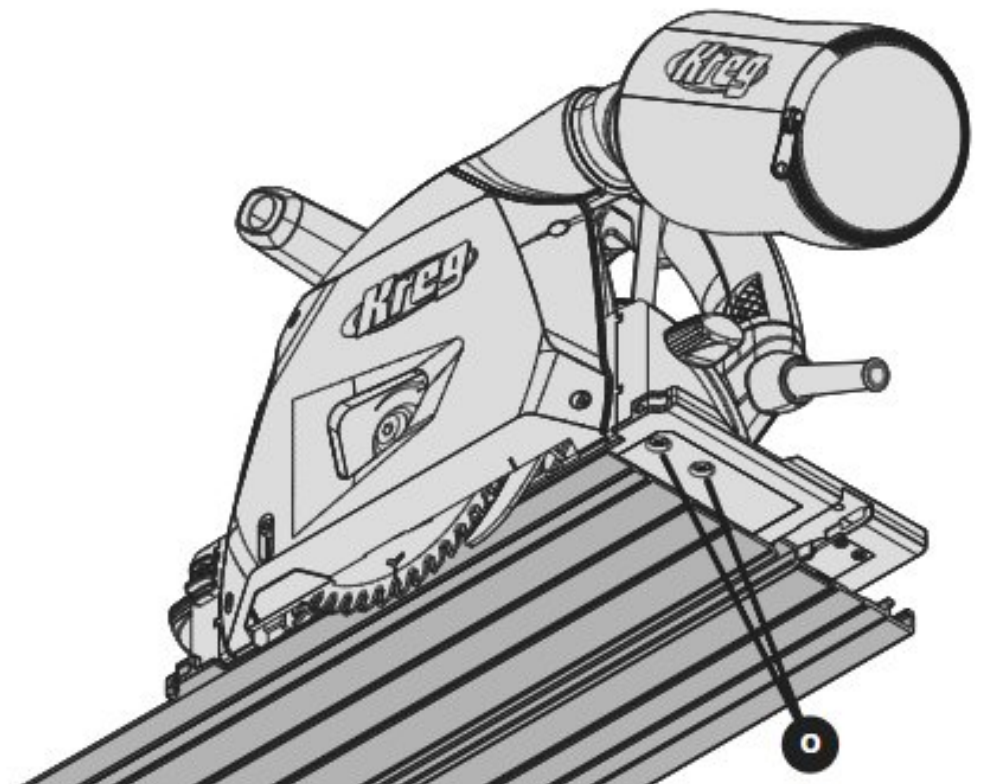

8 Changing the Blade

WARNING Disconnect saw from power before making any adjustments.

a. Loosen the cut-depth stop (Q) and let it drop out of the way.

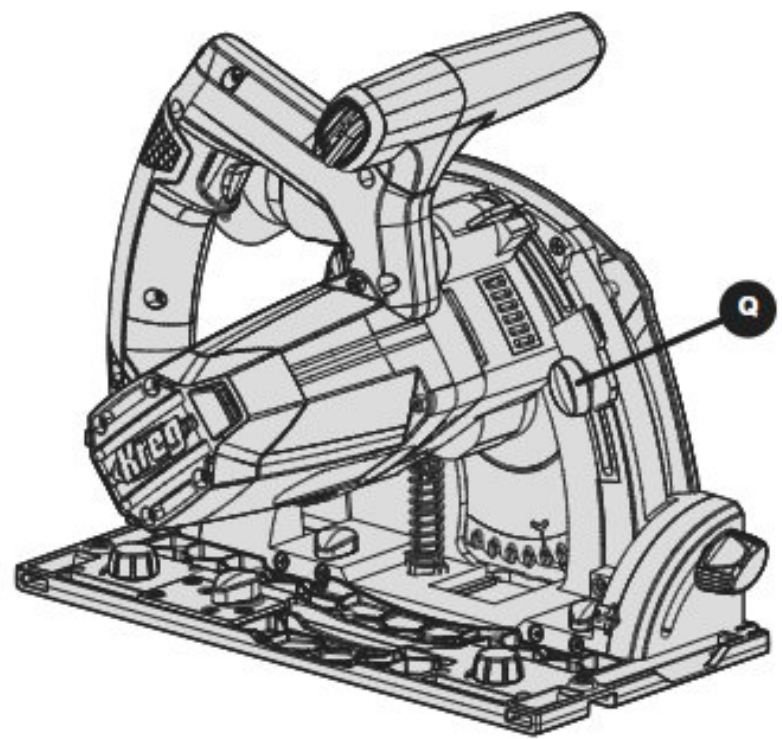

b. Set the blade mode selector (P) to the blade change mode position.

Cut Mode

Blade Change Mode

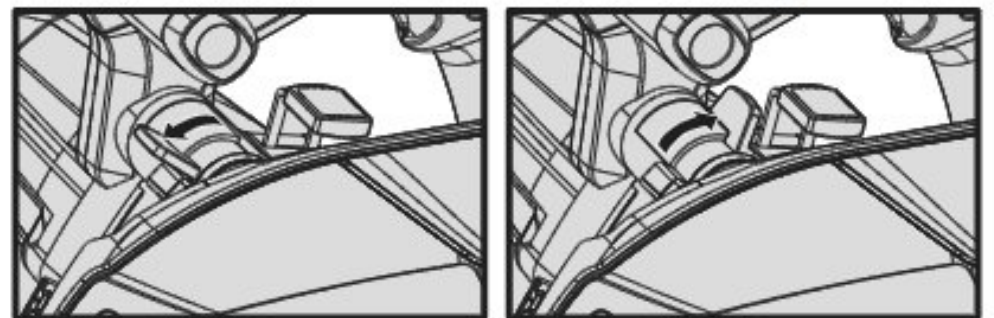

c. Press and hold the switch interlock (G).

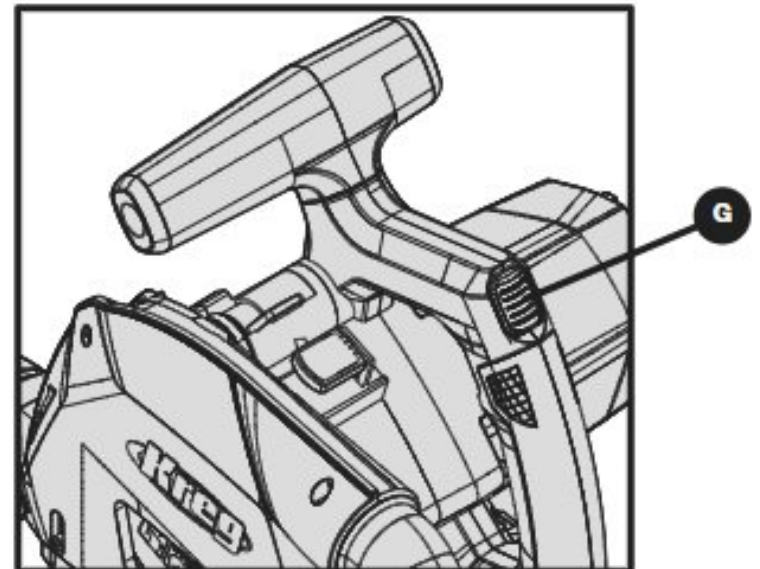

d. Plunge the saw until it stops and release the switch interlock (G). The saw remains in this position.

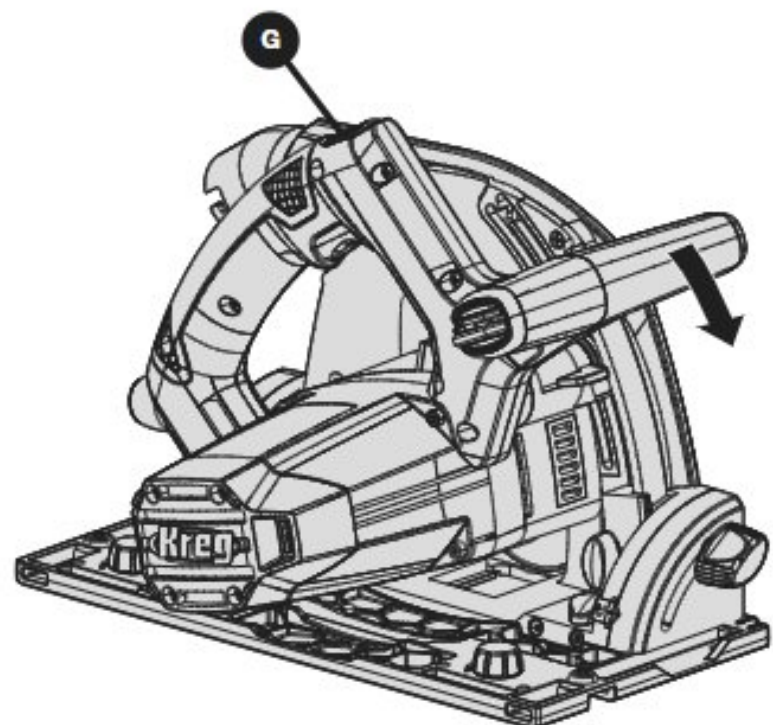

8 Changing the Blade (continued)

- e. Press and hold the arbor lock (M) and rotate the blade (W) clockwise until the lock engages. Continue to hold the arbor lock (M).

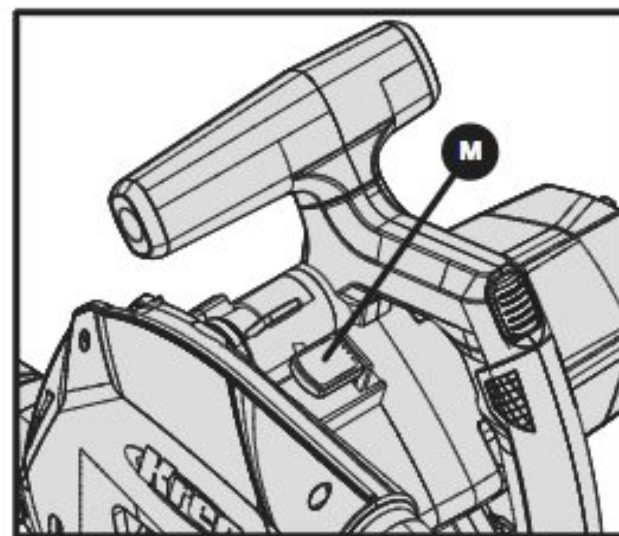

- f. Using the large hex wrench (L) stored in the forward grip (J), remove the arbor screw (YY) and flange washer (ZZ).

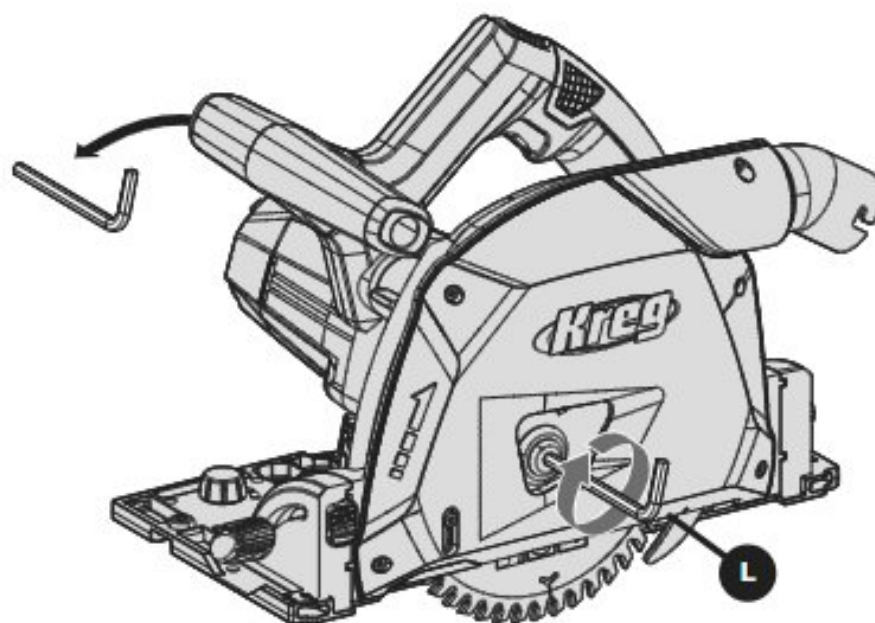

IMPORTANT The arbor screw has left-hand threads. Turn it clockwise to loosen the washer, by rotating the wrench clockwise.

- g. Release the arbor lock button (M).

- h. Remove the blade (W), install a replacement then re-install and tighten the flange washer (ZZ) and arbor screw (YY) by rotating the wrench (L) counterclockwise. Be sure to hold down the arbor lock (M) when tightening.
- i. Press and hold the switch interlock (G) and push down on the saw to release the plunge lock.
- j. Release downward pressure and return the saw to full-up position.

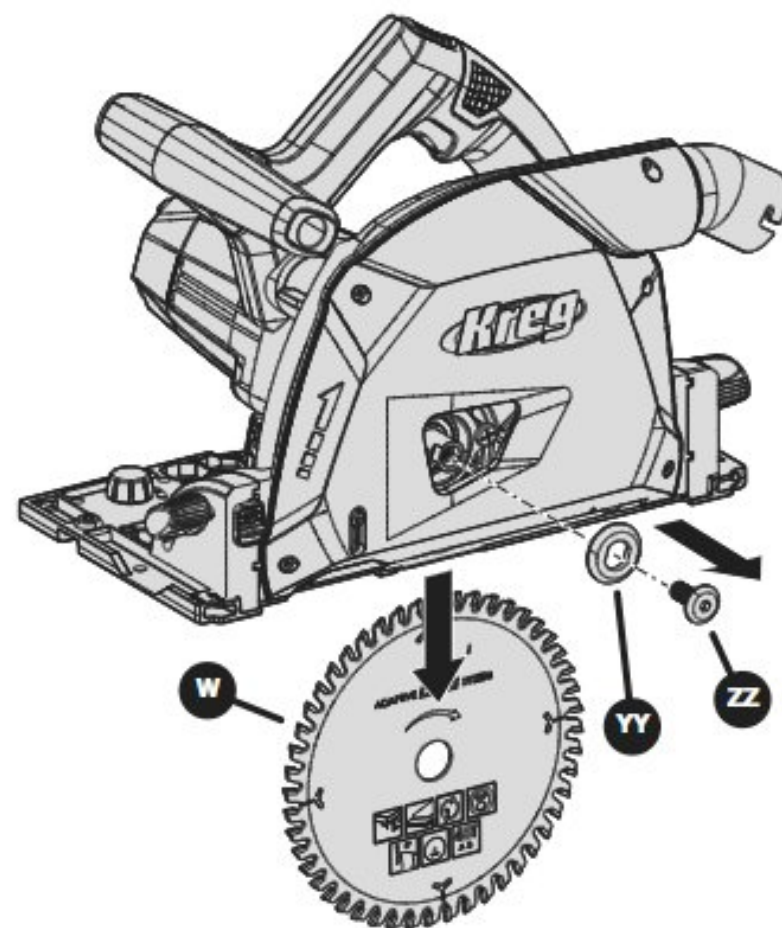

- k. Return the blade-mode selector (P) to the cut mode.

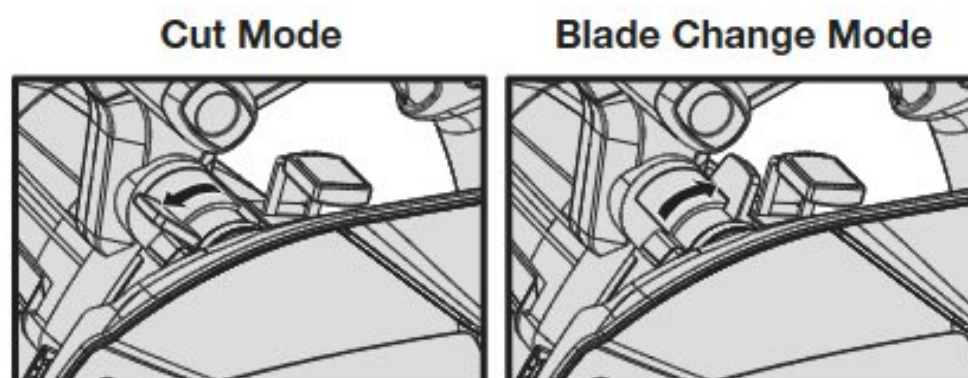

8 Changing the Blade (continued)

IMPORTANT Install the blade with the teeth oriented for clockwise rotation when viewed from the blade-side of the saw. Tooth orientation must match the blade-rotation indicator arrow (Z) on the saw.

Correct Blade-Tooth Orientation

Clockwise tooth orientation

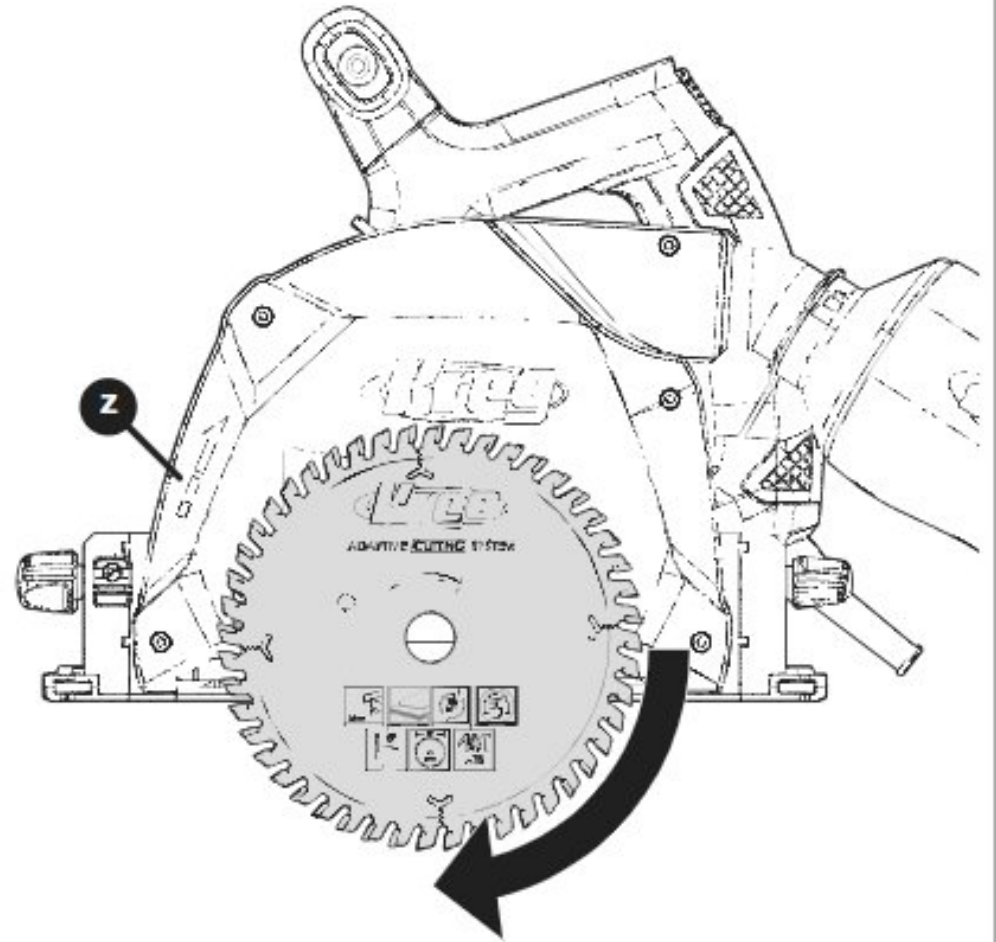

Incorrect Blade-Tooth Orientation

Counterclockwise tooth orientation

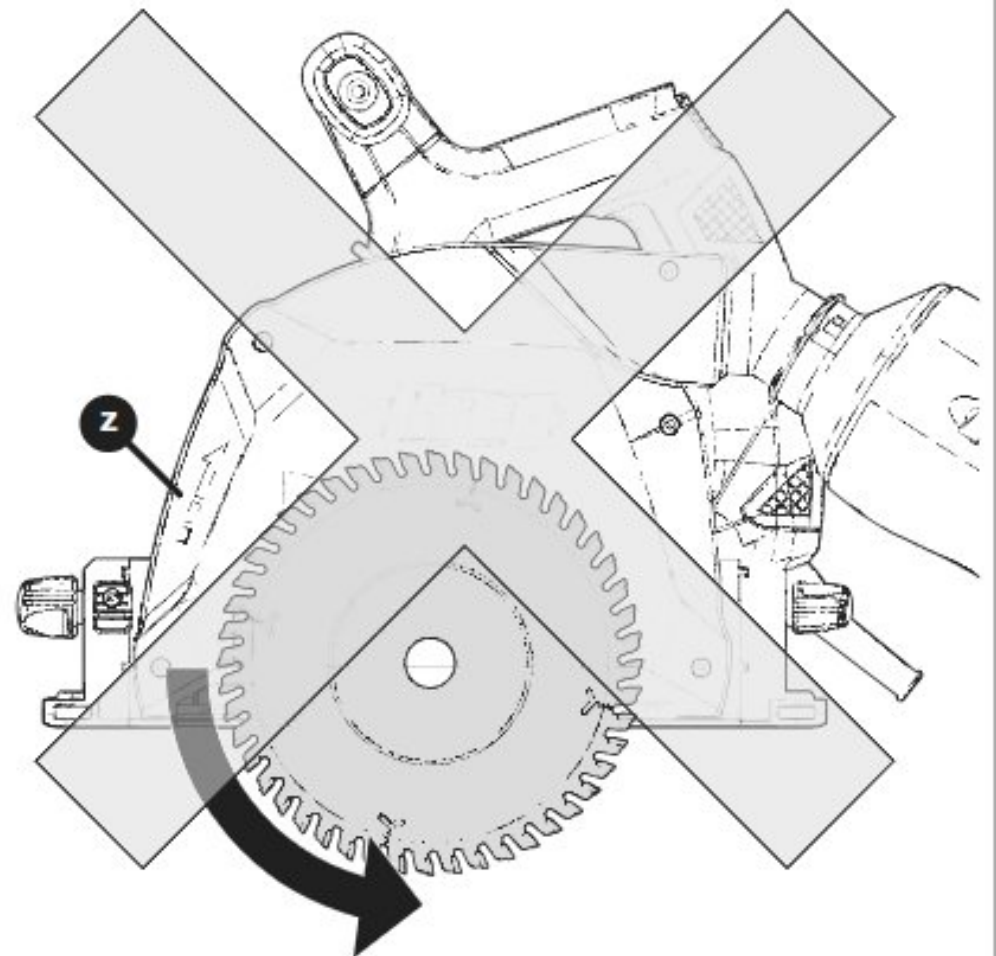

Operation

1 Straight Cuts

IMPORTANT Maximum depth of cut at 0° is 2-1/8 in. (54 mm).

WARNING Always hold the saw with both hands when cutting. Keep one hand on the switch handle and the other on the forward grip.

WARNING This saw is intended for cutting wood and wood products only. Do not cut metal, masonry, glass, masonry-type planking, cement board, tile, or plastic with this saw.

WARNING Do not tie, tape, or otherwise lock the switch in the on position. Hold by hand only.

IMPORTANT When the workpiece is less than 4 in. (102 mm) wide, support the guide track with scrap pieces of the same thickness as the workpiece.

- Set cut depth to 1/8 in. (3 mm) more than workpiece thickness.
- Set the blade mode selector (P) to cut mode, adjust the track adjustment knobs (E) and engage the anti-kickback control (F).
- Align the anti-chip strip (CC) of the guide track (BB) with your measured cut marks. The workpiece must be under the guide track (BB) with the waste piece to the outside.

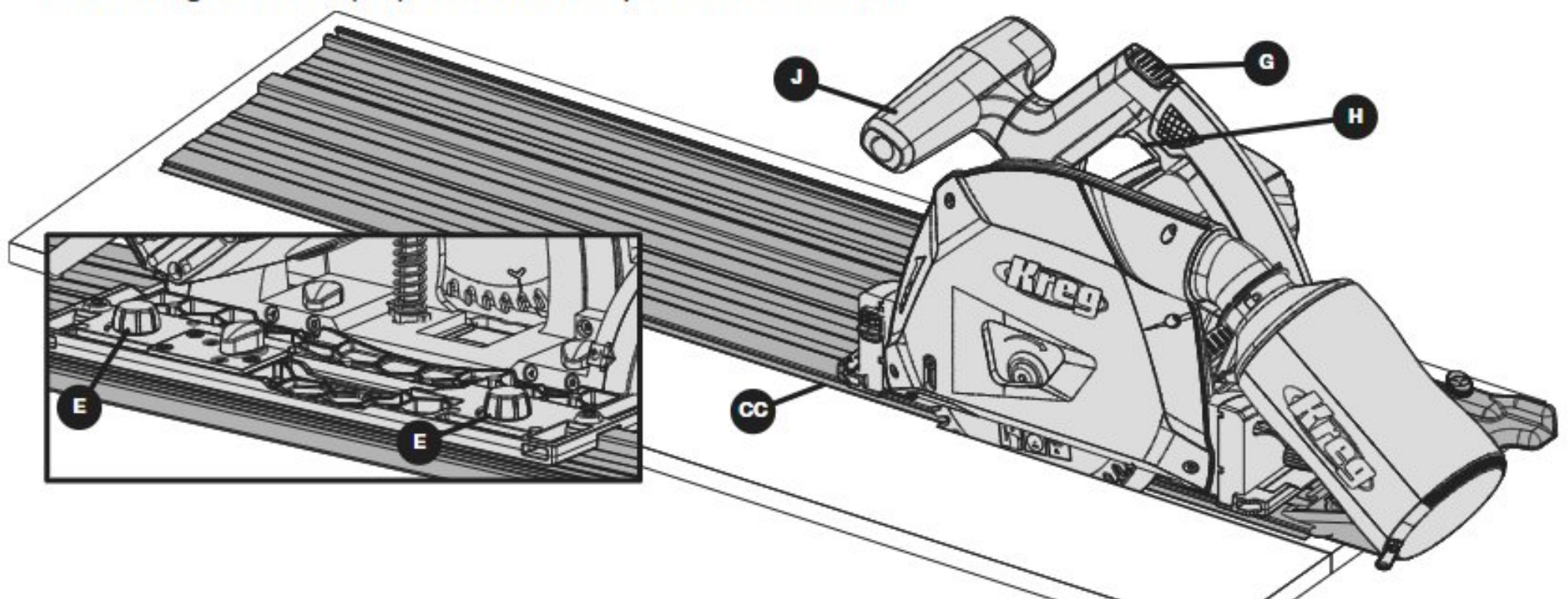

- Position the saw on the guide track (BB), press the switch interlock (G) and depress the switch (H). Let the saw come up to full speed.
- Plunge the saw to cutting depth and push the saw forward.
- At end of cut, release downward pressure and return the saw to full-up position. Allow the blade (W) to stop before lifting the saw from the guide track (BB).

IMPORTANT When interrupting a cut, continue to hold the saw in the plunge position, release the switch, and wait for the saw blade to come to a complete stop. Release downward pressure to retract the blade. To resume, with the power off, plunge the saw to cutting depth to ensure the blade is centered in the saw kerf. Release downward pressure to retract the blade. Depress the switch, plunge the saw to cutting depth, and continue the cut.

WARNING The saw is equipped with a riving knife that automatically extends with the blade. This is an important part of the anti-kickback protection. Periodically check to make sure it operates freely. If you have any concerns about the operation of the riving knife, do not use the saw and contact Kreg Customer Experience.

2 Bevel Cuts

IMPORTANT The Kreg plunge saw has a bevel range of -1° to 47° with stops at 0° and 45° . **Maximum depth of cut at 45° is 1-1/2 in. (38 mm).**

- Loosen the bevel locks (A).
- Tilt the saw and align the bevel indicator (C) with the desired angle on the bevel scale (B).
- Tighten the bevel locks (A).

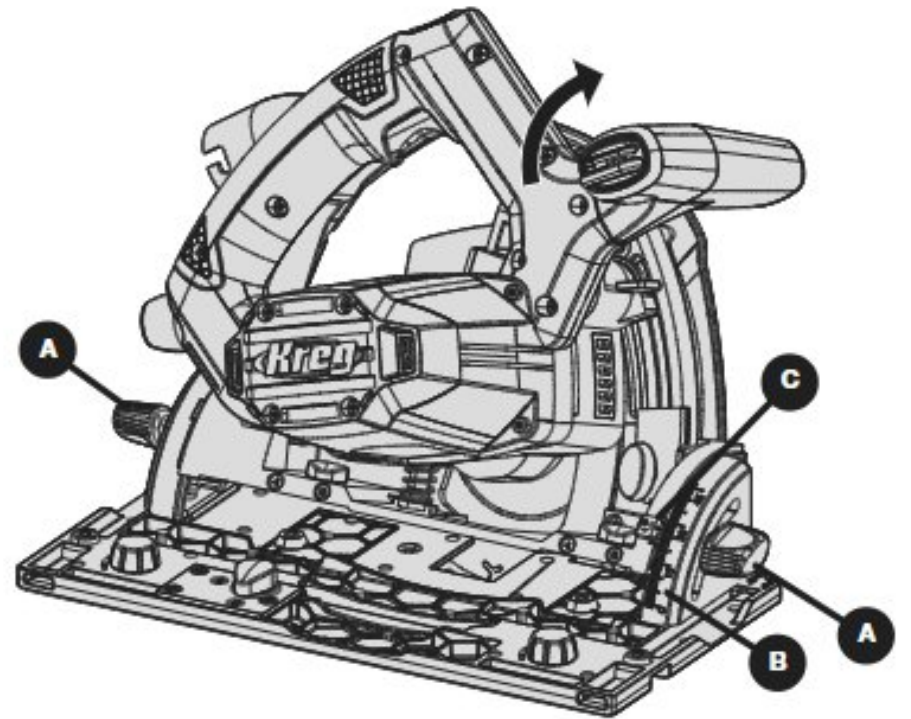

Bevel Overrides

Fitting two parts together when the edge of one part is not square requires cutting a slight compensating bevel on the second part. When the needed bevel adjustment falls below the 0° mark on the bevel scale, use the -1° override. In similar fashion, compensate for a miscut bevel on one part of a miter joint by using the $+47^{\circ}$ override. Both procedures are shown below

3 -1° Override

- Loosen the bevel locks (A).
- Bevel saw to approximately 30° to access the -1° override locks (D).
- Turn both -1° override locks (D) to the -1° position.
- Bevel saw down to -1° .
- Tighten the bevel locks (A).

To return to the 0 - 45° bevel range, loosen the bevel locks (A), turn the -1° override locks (D) to the 0° position, tilt the saw down, and tighten the bevel locks (A).

IMPORTANT Always return both -1° override locks to the 0° position after making your cut.

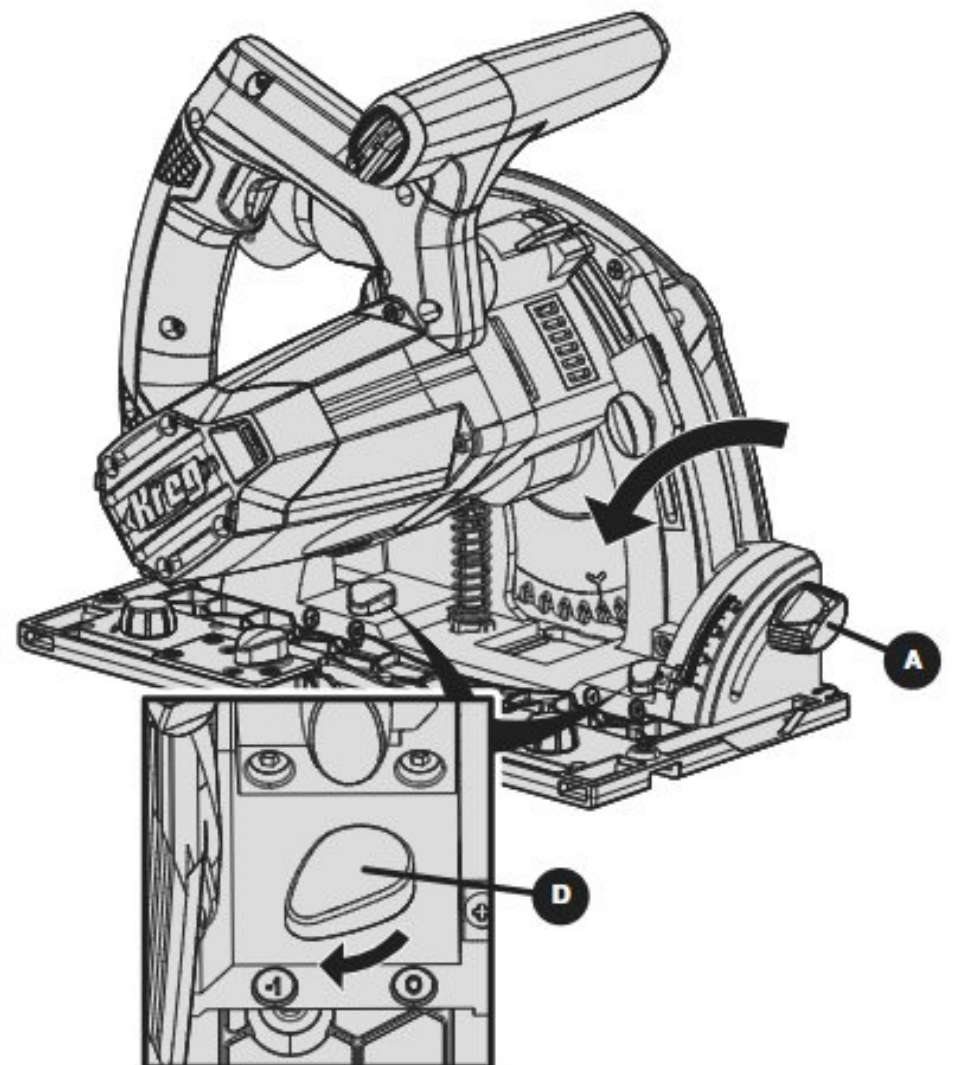

4 +47° override

- Loosen the bevel locks (A).
- Tilt the saw to 45°.
- Push down 47° override button (S).
- Tilt the saw to 47°.
- Tighten the bevel locks (A).

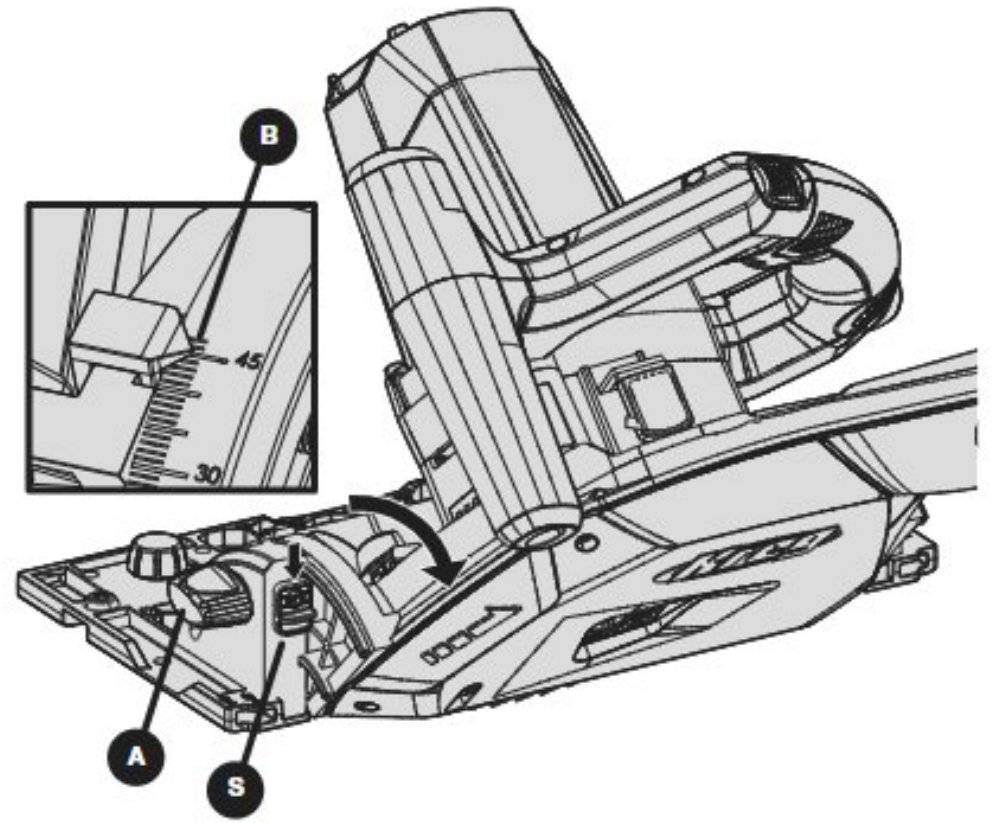

Care and Cleaning

WARNING To reduce the risk of injury, disconnect the plug from the power source before performing any maintenance, adjustments, or repairs.

IMPORTANT To maintain product safety and reliability, and to guarantee the use of genuine Kreg replacement parts, contact Kreg Customer Experience before attempting all repairs or maintenance not covered in this manual.

Cleaning

Blow dirt and dust out of all air vents, air intakes, and blade housing with compressed air at least once a week. Never use solvents or other harsh chemicals for cleaning the non-metallic parts of the tool. Use a cloth dampened only with water and mild soap. Never let any liquid get inside the tool. Never immerse any part of the tool in liquid.

Lubrication

This tool comes lubricated for the life of the unit from the factory. Under normal operating conditions, no further lubrication is necessary.

Motor Brushes

To prevent damage to the motor, this saw features a brush system that automatically stops the saw when the brushes wear out. To obtain replacement brushes, contact Kreg Customer Experience, and refer to **Replacing the Motor Brushes** on page 30.

Periodic Inspections

Periodically inspect the operations for the following:

- **Plunge saw return:** If the saw returns slowly or if the blade fails to fully retract, the plunge return assembly could be damaged. Do not attempt to repair. Contact Kreg Customer Experience with additional questions.
- **Anti-kickback feature:** Inspect the anti-kickback control during normal operation and check after every instance of kickback. Inspect the anti-kickback components for visible damage. Place the saw on the track with the anti-kickback control engaged and pull back on the saw to verify that the saw does not move backward. Do not attempt to repair the anti-kickback control. Contact Kreg Customer Experience with additional questions.
- **Riving knife:** The riving knife should move freely while plunging the saw. Verify that the riving knife is centered within the width of the blade teeth. Inspect the riving knife for bends, dents, or damage. Do not attempt to repair or remove the riving knife. Contact Kreg Customer Experience with additional questions.
- **Power cord and plug:** Examine the power cord and plug for knicks, cuts, or any other damage. Do not attempt to repair the cord or plug. Contact Kreg Customer Experience with additional questions.
- **Switch and switch interlock:** Verify that both automatically return to the off position when released. Do not use the saw if either the switch or switch interlock is malfunctioning. Do not attempt to repair the switch or switch interlock. Contact Kreg Customer Experience with additional questions.

Accessories

Guide Tracks

Additional guide track is available providing additional cutting capacity. Refer to Kregtool.com for available lengths and cutting capacities.

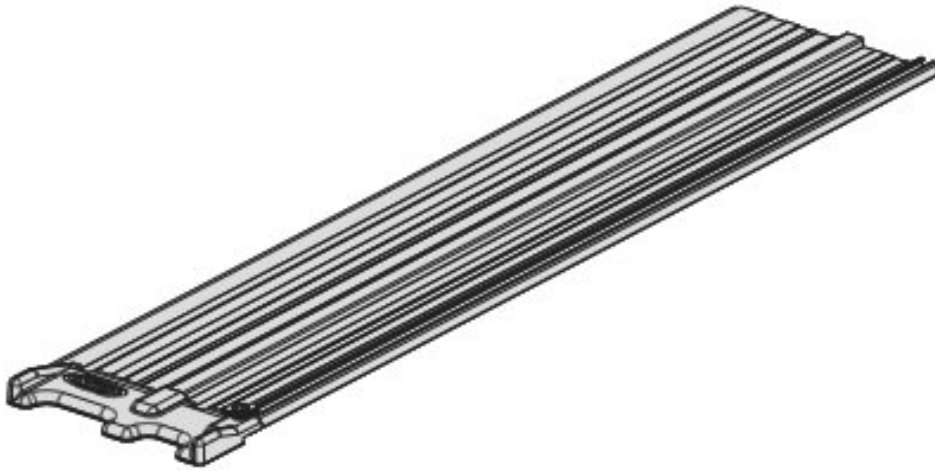

Guide Track Connectors

Joins and aligns guide track sections.

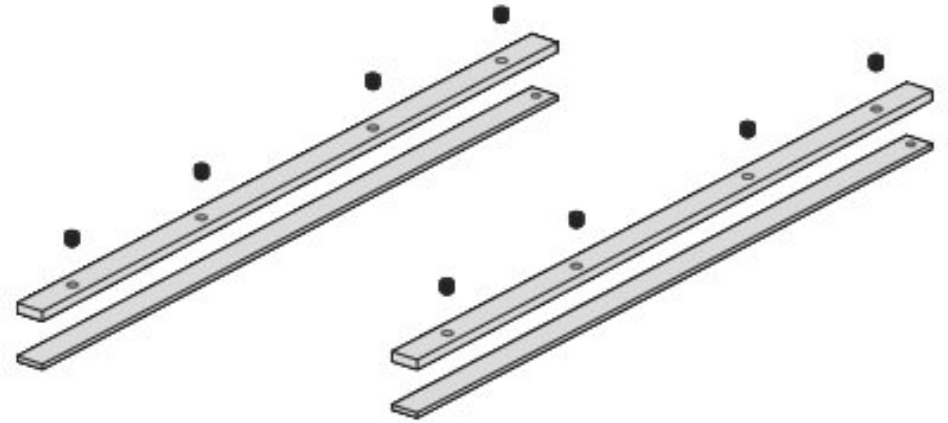

Glide Strips

Replacement 2-Pack in various lengths.

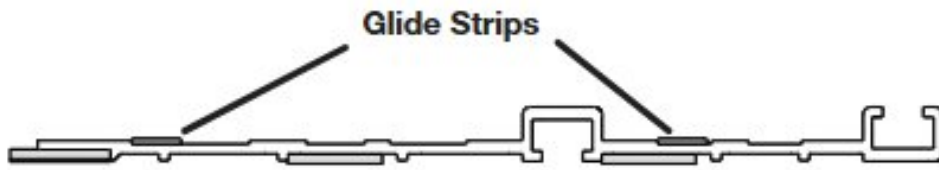

Anti-Chip Strip

Replacement strip in various lengths (sold in a kit with Anti-Slip Strips).

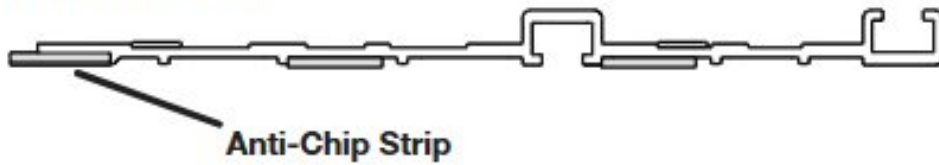

Anti-Slip Strips

Replacement 2-Pack of strips in various lengths (sold in a kit with Anti-Chip Strip).



Rip Guides

Cut capacity from 0 in. (0 mm) to 13 in. (330 mm).

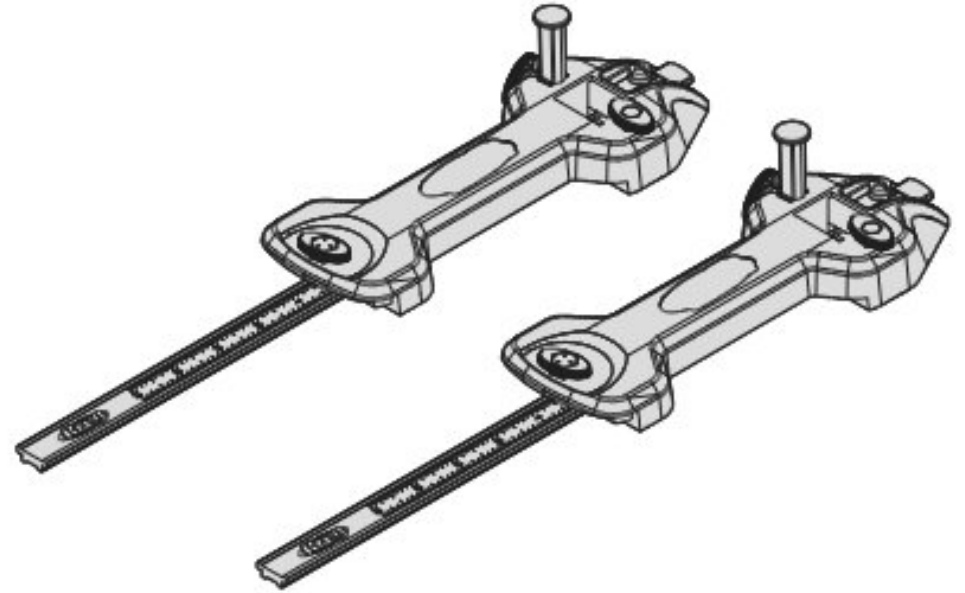

Saw Blade

High-performance 6.5-inch diameter, 48-tooth saw blade with 20 mm arbor size and rated for 7000 RPM



Parallel Guides

Cut capacity from 12 in. (305 mm) to 96 in. (244 cm).

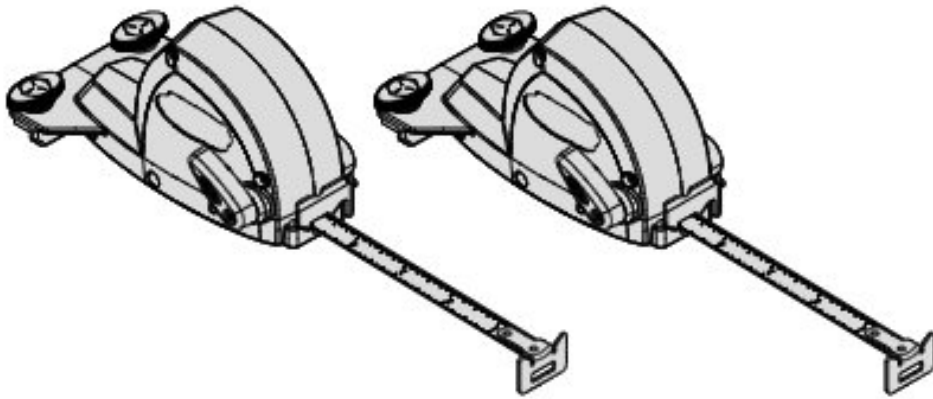

Splinter Guards

3-Pack

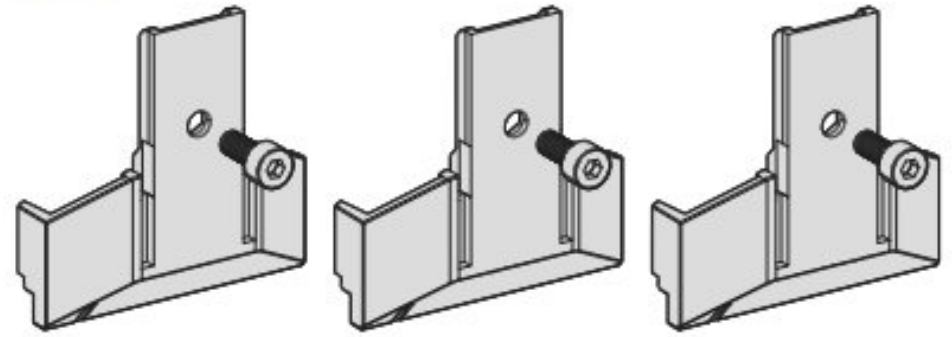

Troubleshooting

Problem	Solution
Burning material	Check the toe in. Refer to Toe-In Adjustment on page 16.
	Remove the blade and carefully clean the blade and teeth with commercially available blade cleaner
	Replace the blade. Refer to Changing the Blade on page 18.
Splintering of off-cut	Verify the splinter guard contacts the workpiece.
	Verify there is not a gap between the inside edge of the splinter guard and the blade teeth. If the splinter guard was not tightened before use or loosened during use, it may have been damaged. Replace the splinter guard.
Splintering on the workpiece	Verify the front edge of the blade is flush with the anti-chip strip. If there is a gap between the blade and anti-chip strip, replace and re-trim the strip. Refer to Trim the Anti-Chip Strip on page 14.
Poor dust collection	Empty the dust bag after every second or third cut.
	Occasionally blow out the dust fabric with compressed air.
	Unplug the saw and verify dust is not clogging the blade housing or dust port. Blow out the housing and port with compressed air.
	Unplug the saw and remove the dust shroud to check and remove saw dust build up within the blade housing.
	When making many cuts in one work session, connect the saw to a shop vacuum.
Cuts slightly off 90°	Verify the -1° override locks are not engaged.
	Check the bevel calibration. Refer to Calibrate the Bevel Scale on page 12.
Motor bogs down	Reduce the feed rate (movement of saw along the track). Wet or hardwoods require a slower feed rate.
	Blade kerf in the workpiece may be closing and pinching the blade. Stop cutting, remove the saw from the workpiece, and start the cut over to widen the saw kerf. If pinch persists, discard the workpiece.
	Remove the blade and carefully clean the blade and teeth with commercially available blade cleaner.
	Replace the blade. Refer to Changing the Blade on page 18.

Problem	Solution
Motor stops working after extend use	Inspect the power cord for damage. If damaged, contact Kreg Customer Experience
	Switch and/or switch interlock could be damaged or worn. If damaged or worn, contact Kreg Customer Experience.
	Motor brushes may be worn and require replacing. Contact Kreg Customer Experience. Refer to Replacement Parts on page 28.
Wavy cut	Verify the track adjustment knobs are properly adjusted. They should be tight enough to eliminate play between the saw and guide track without hindering movement of the saw along the guide track.
	Inspect the track adjustment knobs for damage. If damaged, contact Kreg Customer Experience.
	Clean the anti-slip strips on the underside of the guide track with a damp cloth and remove dust from the workpiece. If the guide track slips sideways on a slick workpiece surface, secure the track to the workpieces with optional Track Clamps that are available from Kreg.
Saw will not plunge to desired depth	Check if the blade mode selector is set to blade change mode, if yes, switch to cut mode.
	Make sure the splinter guard has been properly trimmed.
	Make sure the anti-chip strip on the guide track has been properly trimmed.
Saw does not sit flat on the track	Verify the anti-kickback control is not engaged when initially placing the saw on the guide track.
	Clean the guide track of any debris.
	Loosen the track adjustment knobs and re-adjust as needed.
Saw does not glide down the track	Loosen the track adjustment knobs and re-adjust as needed.
Saw Blade removal	Clean the guide track of any debris.
Saw Blade removal	Replace the glide strips if necessary.
Saw Blade removal	Arbor screw is reverse threaded, turn clockwise to loosen and remove. Turn counterclockwise to tighten.
Saw catches at beginning of cut	Check that both track adjustment knobs are fully engaged on the guide track.
Saw catches at beginning of cut	Loosen the track adjustment knobs and re-adjust as needed.

Replacement Parts

1 Replacing the Arbor Screw and Flange Washer

- a. Refer to **Changing the Blade** on page 18.

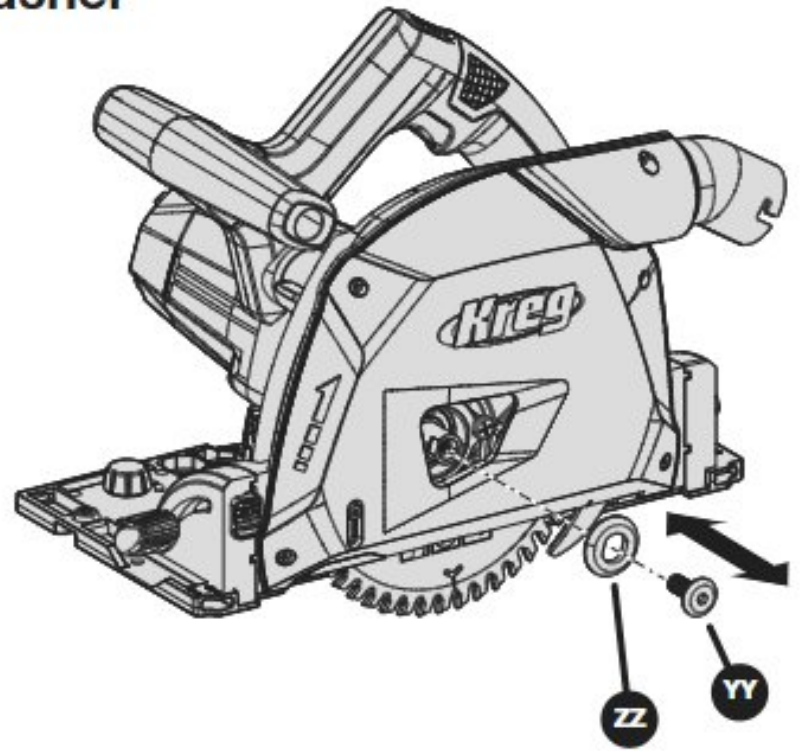

2 Replacing the Blade Mode Selector Label

- a. If the blade mode selector (P) label is missing or damaged, contact Kreg Customer Experience to order a new label.
- b. Apply the label so that the Cut Mode image faces the front of the saw and the image of the wrench faces the back of the saw.

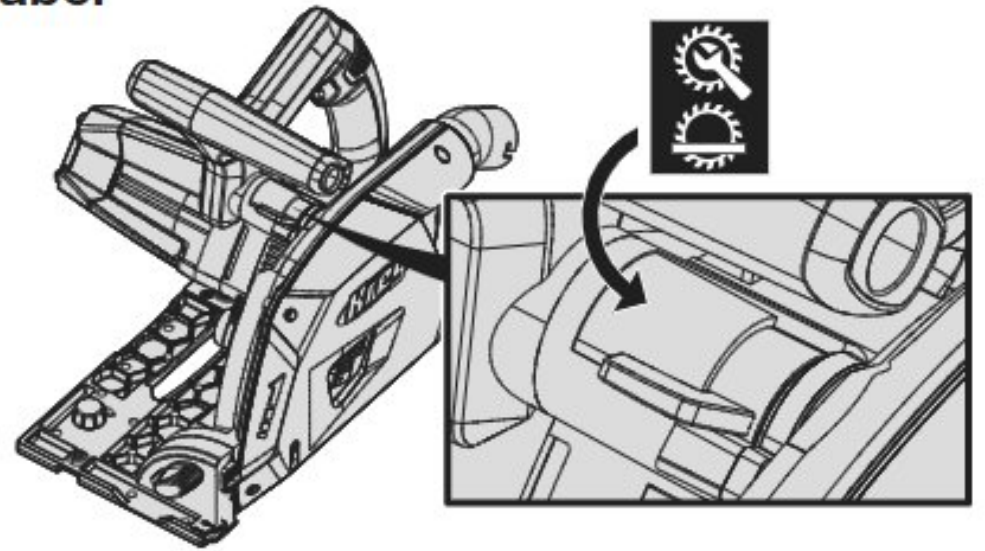

3 Replacing the Dust Port

- a. Remove the small hex wrench (K) from the forward grip (J).
- b. Remove the screws (1) from the dust shroud (2).

Note To prevent stripping out the screws, ensure the wrench is firmly in the head of the screw.

- c. Remove the dust shroud (2).
- d. Take out the previous dust port (T).
- e. Put in the new dust port (T). Ensure that it aligns with the housing completely.
- f. Put the dust shroud (2) back on and tighten the screws (1).
- g. Put the hex wrench (K) back in the forward grip (J).

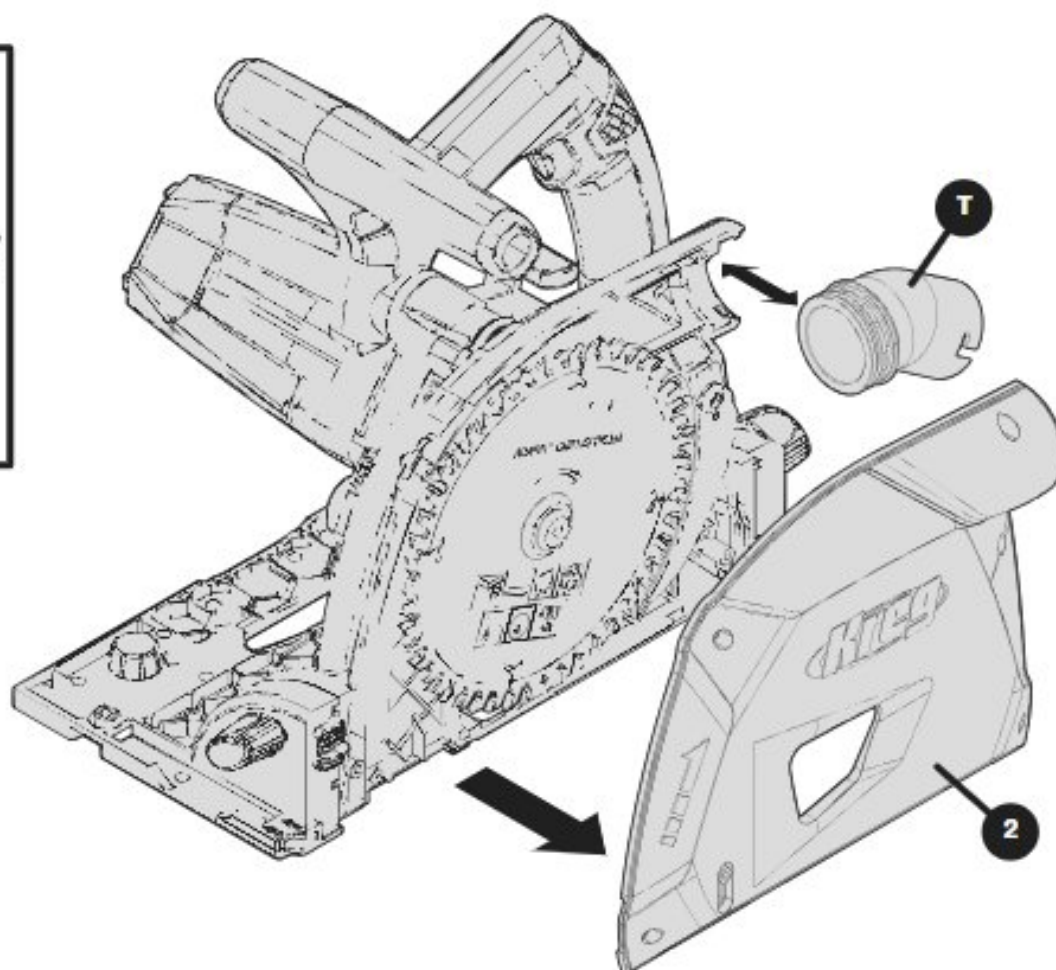
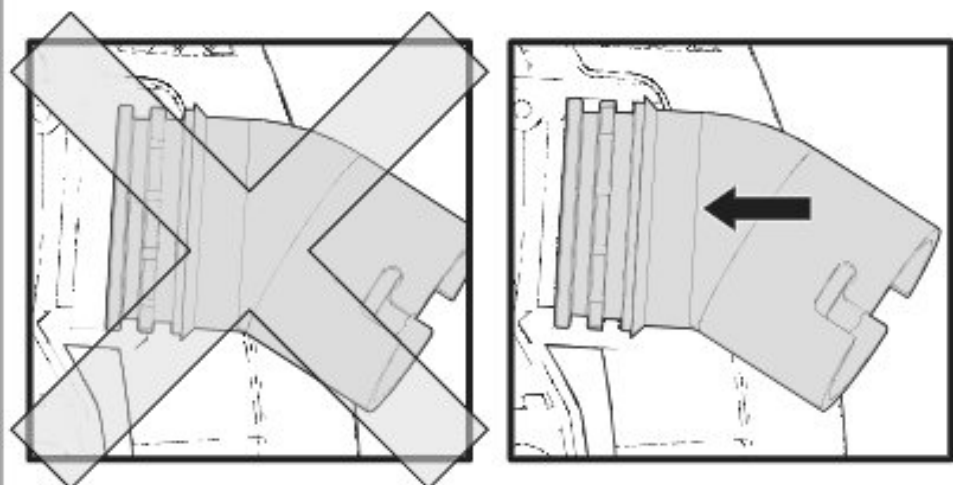
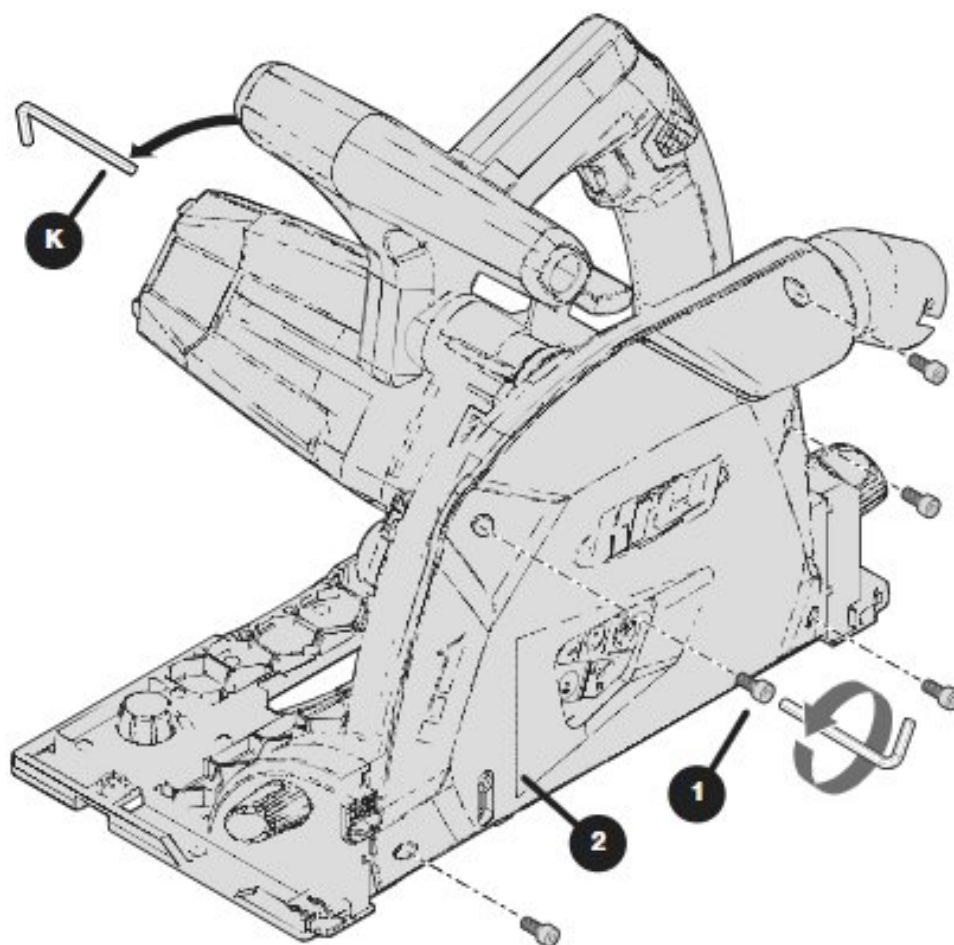

4 Replacing the Motor Endcap

- a. Remove the four Philips screws (1) using a Philips screwdriver (not included).
- b. Remove the previous endcap (2).
- c. Place the new endcap (2) with the Kreg logo facing upright.
- d. Replace and tighten the screws (2).

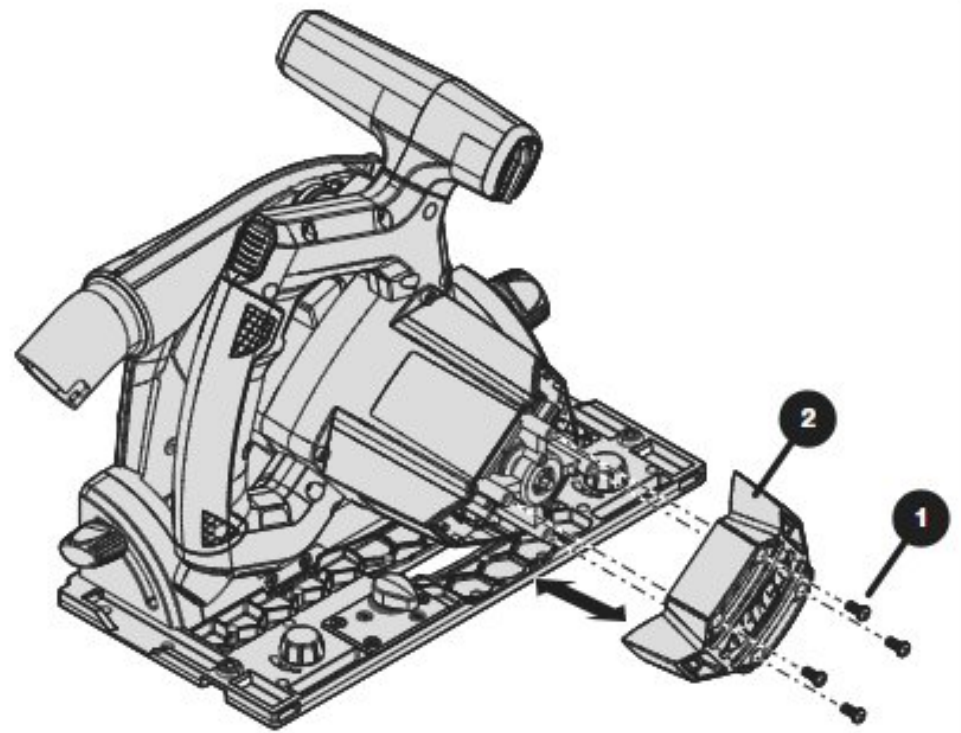

5 Replacing the Motor Brushes

- a. Remove the Motor Endcap (see **Replacing the Motor Endcap** on page 30). Both brushes (3) are now visible.
 - b. For each brush (3), unplug the wire (1).
 - c. Using a small flathead screwdriver, pull back the spring (2) that holds the previous brush (3) in place in the housing area.
- IMPORTANT** Keep tension on the spring at all times.
- d. Remove the previous brush (3).
 - e. Insert the new brush (3).
 - f. Release the spring (2) on the housing area.
 - g. Plug in the wire (1).
 - h. Once both brushes (3) have been replaced and rewired, replace the Motor Endcap and tighten the screws.

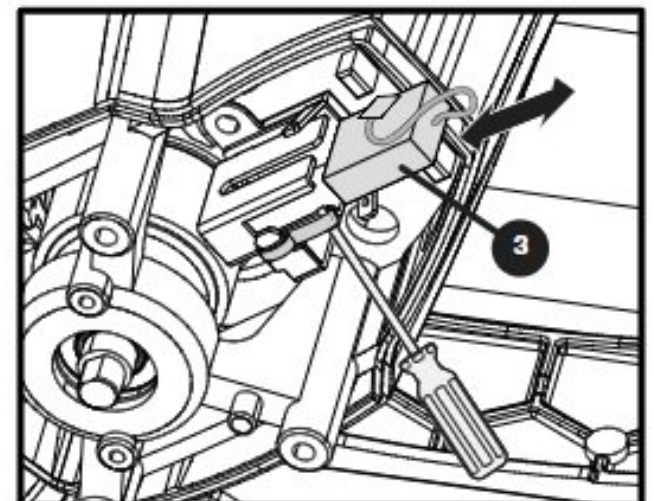
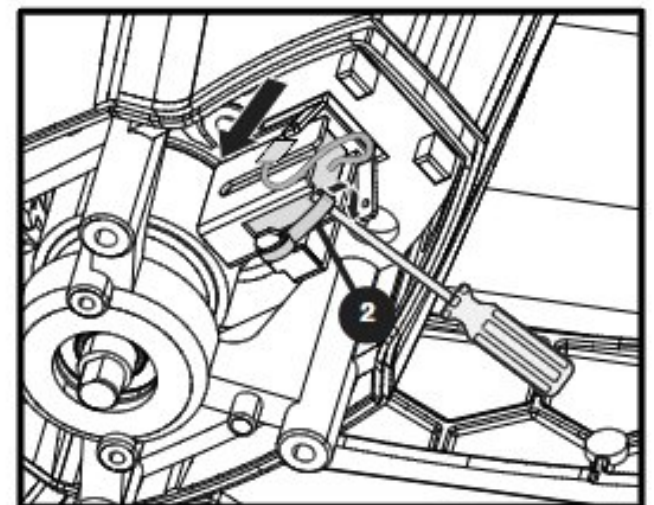
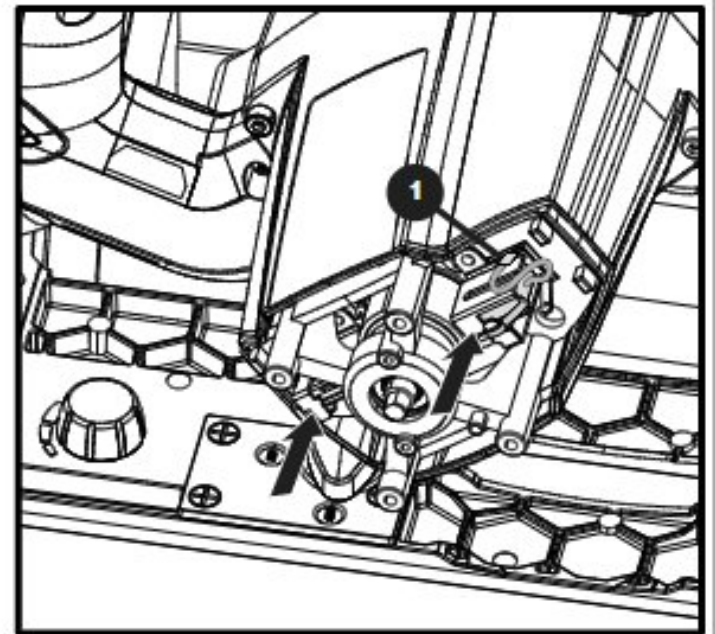
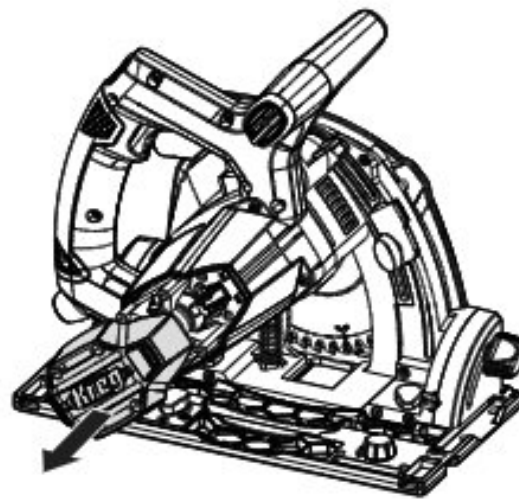

6 Replacing the Bevel Locks

- Set the bevel indicator (C) to zero.
- Loosen and remove each of the two previous bevel locks (A) and washers (1).
- Insert and tighten each of the two new bevel locks (A) and washers (1).
- Ensure the bevel indicator (C) is still set to zero.

IMPORTANT You may need to recalibrate the bevel scale. Refer to **Calibrate the Bevel Scale** on page 12.

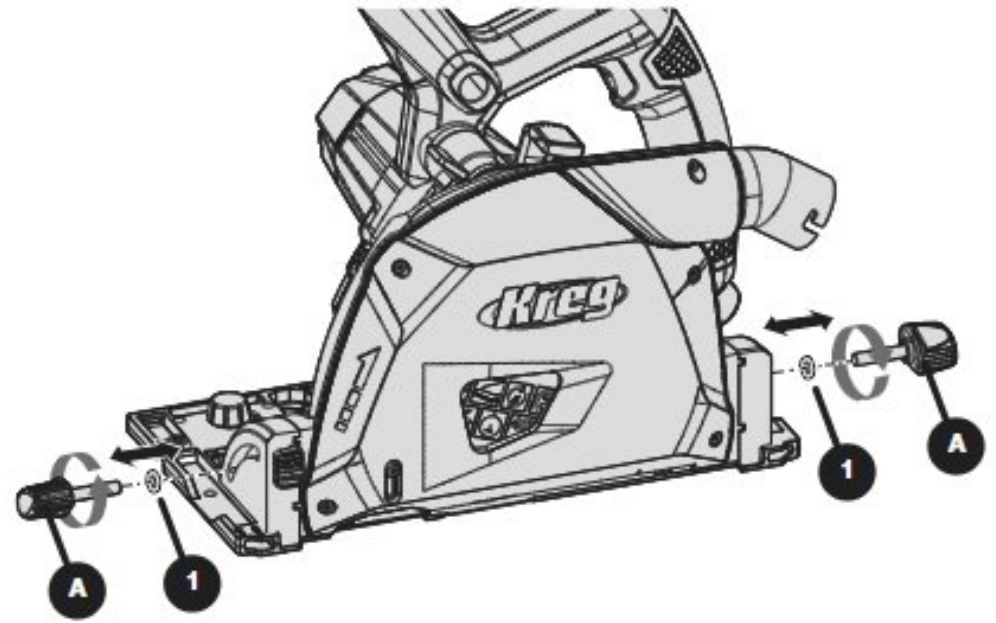

7 Replacing the Bevel Indicator

- Set the bevel indicator (C) to zero.
- Using a small Philips screwdriver, loosen and remove the screw (1).
- Remove the previous bevel indicator (C).
- Insert the new bevel indicator (C).
- Insert and tighten the screw (1).
- Ensure the bevel indicator (C) is still set to zero.

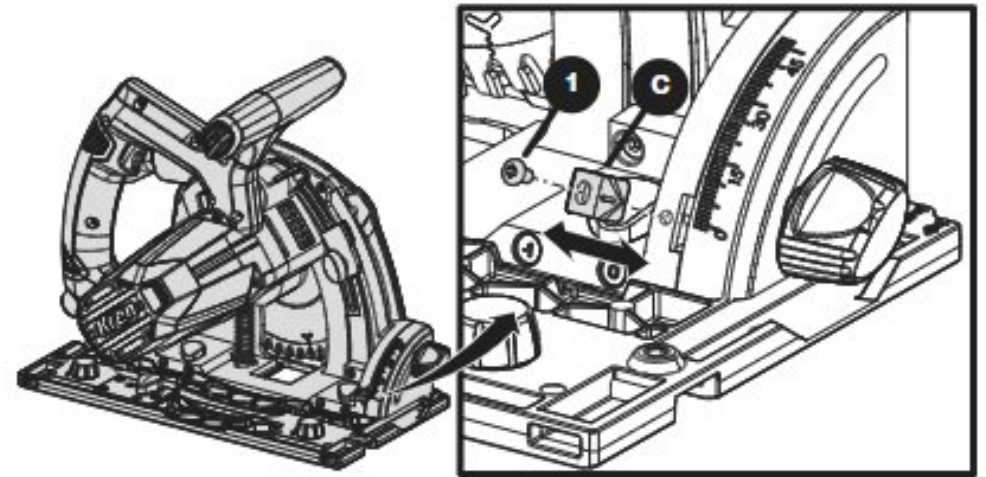

8 Replacing the Cut-Depth Stop Assembly

- Loosen the bevel locks (A) and tilt the saw at a 45-degree angle.
- Using a Philips screwdriver, remove the screw (1) at the top of the cut-depth stop assembly (2).
- Remove the small hex wrench (K) from the forward grip (J) and remove both screws (3) at the base of the previous cut-depth stop assembly (Q).
- Insert the new cut-depth stop assembly (2).
- Insert and tighten the screws (1,3) and put the small hex wrench (K) back in the forward grip (J).
- Restore the saw to its original angle and tighten the bevel locks (A).

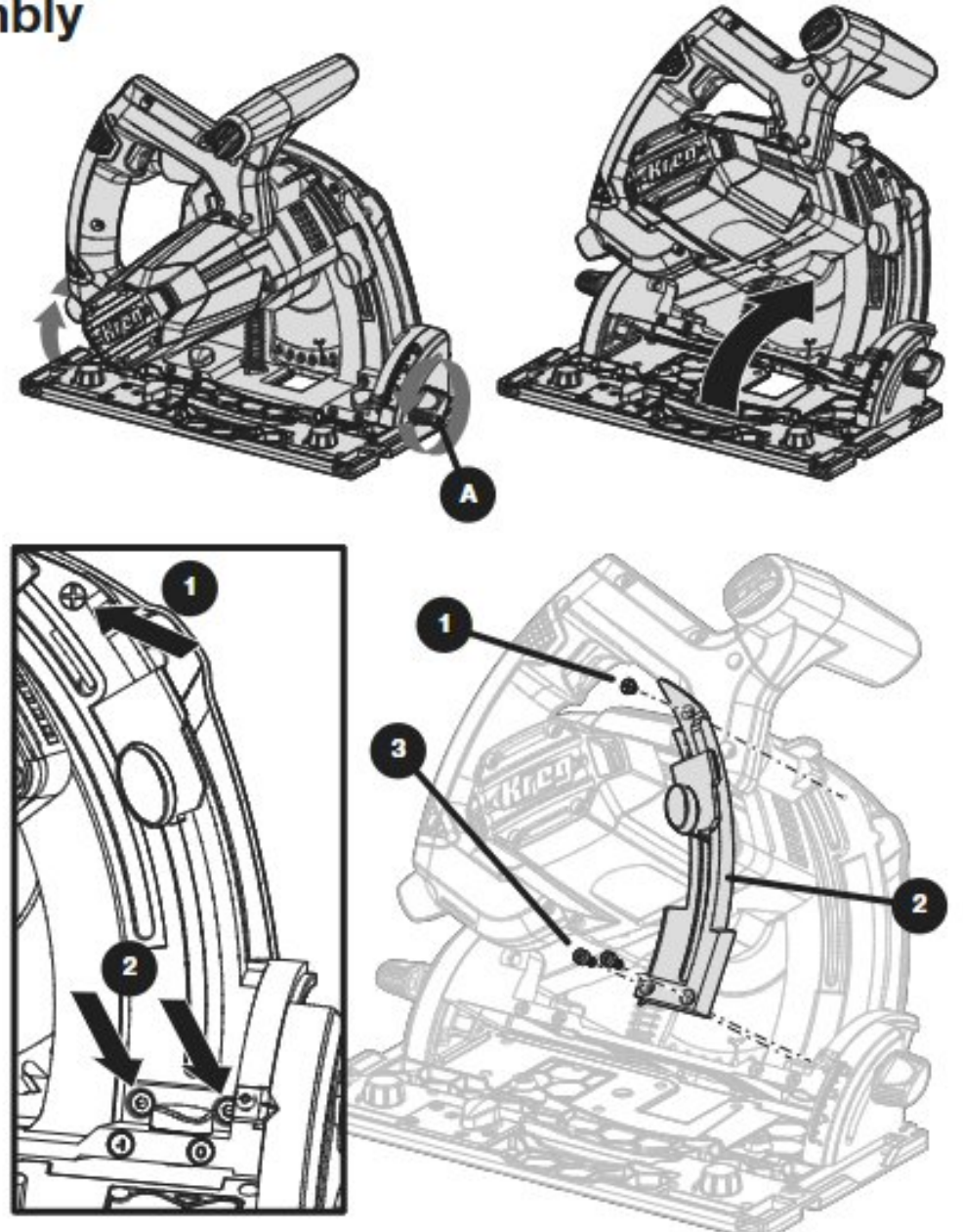

9 Replacing the Bevel Adjustment Set Screws at the Base

- Remove the small hex wrench (K) from the forward grip (J) and remove the bevel adjustment set screws (N).
- Insert and tighten the new bevel adjustment set screws (N).
- Put the small hex wrench (K) back in the handle.

IMPORTANT You may need to recalibrate the bevel scale. Refer to **Calibrate the Bevel Scale** on page 12.

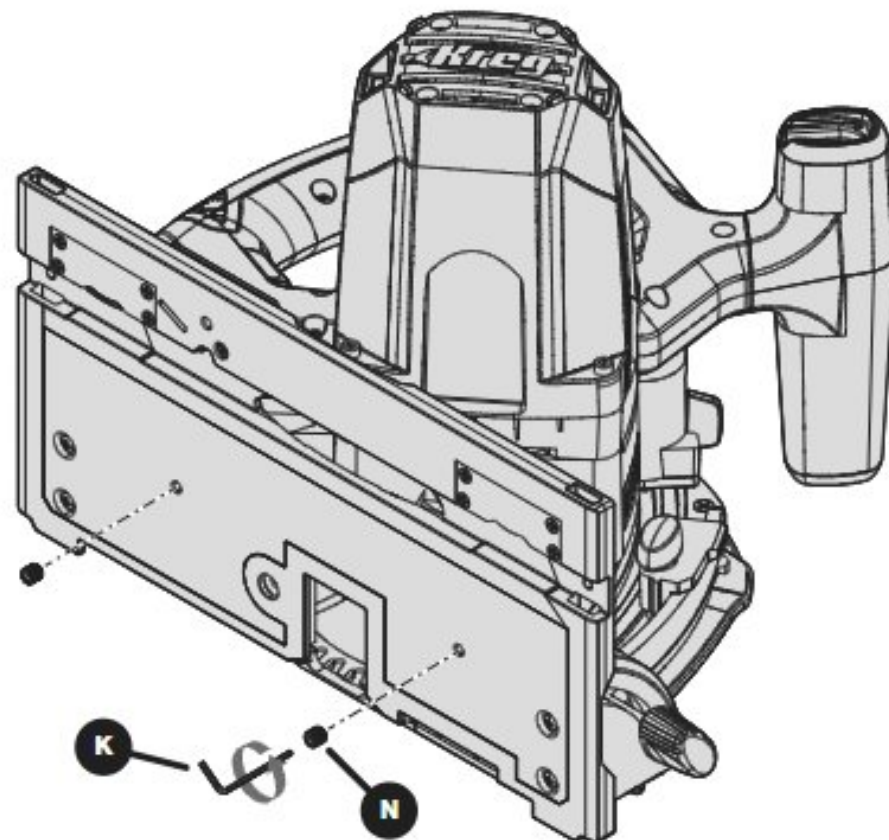

10 Replacing the Bevel Quadrants

- Flip the saw upside down, exposing the base plate (1).
- Using a Philips screwdriver, remove the four toe-in adjustment screws (O).
- Remove the base plate. The bevel quadrants (3) are exposed.
- Remove the bevel locks (A) from the front and the rear.

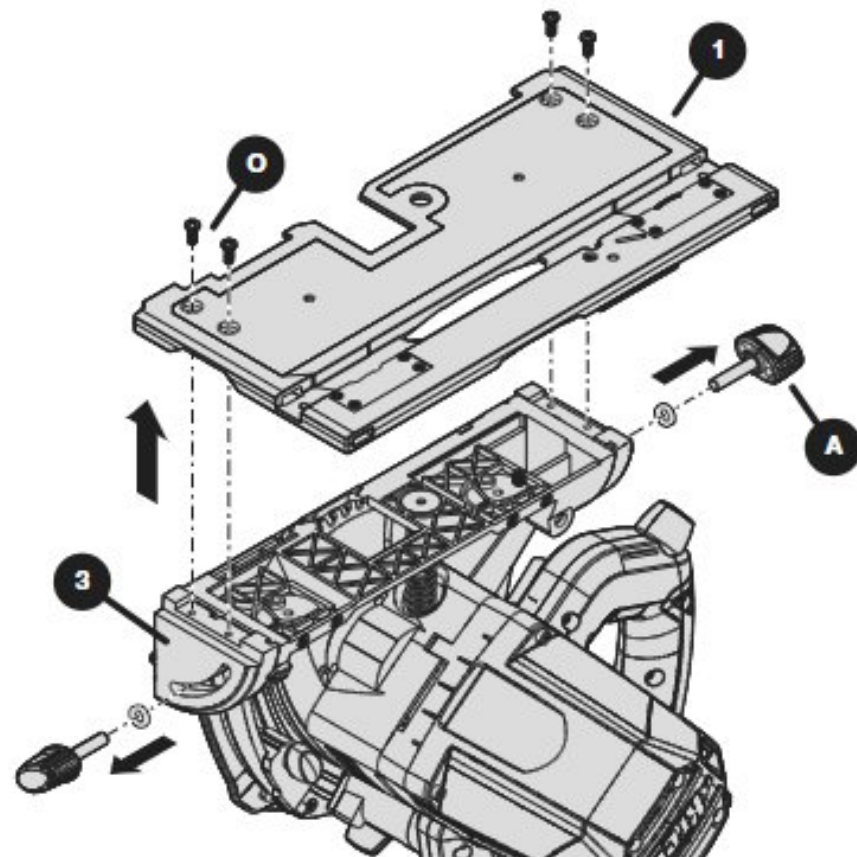

- Remove the bevel quadrants (3).
- Insert the new bevel quadrants (3).

IMPORTANT Ensure the bevel quadrant with the depth scale is in front of the saw and that the blank quadrant is on the rear of the saw.

- Insert and tighten the bevel locks (A).
- Attach the baseplate and tighten the toe-in adjustment screws (O).

IMPORTANT Do not over tighten the toe-in adjustment screws (O).

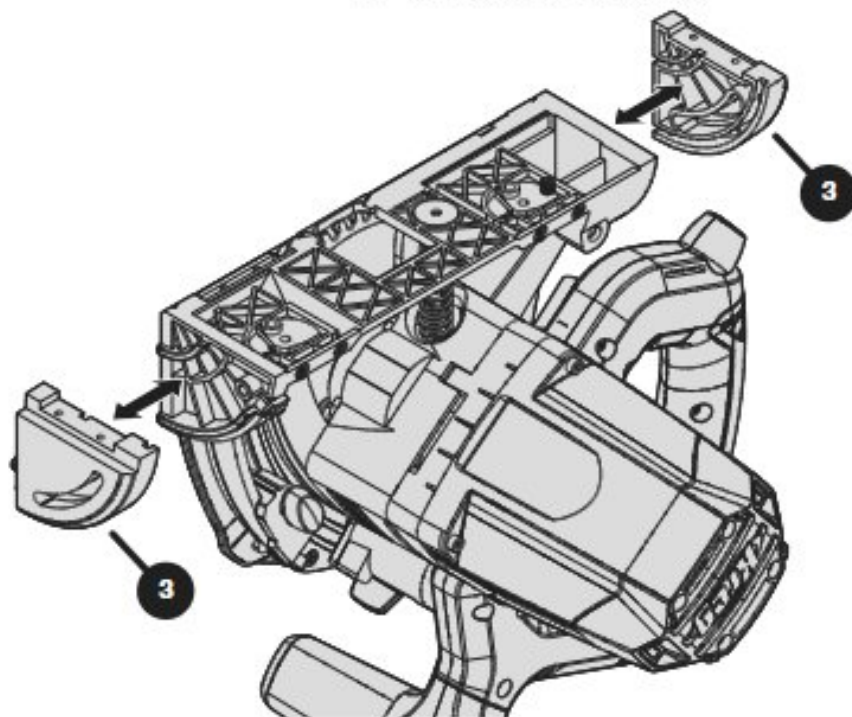

Warranty

Kreg Enterprises, Inc. warrants the ACS-SAWBB (Model # PCS6512) to be free of defects in materials and workmanship for a period of two (2) years from the date of delivery to the original purchaser. This warranty is for purchases from authorized distributors of Kreg products and extends only to the original purchaser. This warranty is not transferable.

During the warranty period, Kreg Enterprises, Inc., at its option, will repair or replace the saw or any component part thereof proving defective. This warranty applies only to use in accordance with all instructions pertaining to operation, maintenance, and safety set forth in catalogs, manuals, and instructions furnished by Kreg Enterprises, Inc.

This warranty does not apply to:

1. Normal wear and tear, corrosion, abrasion, or repairs required due to natural causes or acts of God.
2. Items that would be consumed or require replacement due to normal wear.
3. The cost of removal of components if such removal is authorized by Kreg Enterprises, Inc.
4. Shipment to the Kreg Enterprises, Inc. repair facility.
5. Reinstallation of parts removed for warranty service.

This warranty is null and void if the product has been subjected to:

1. Misuse, abuse, improper service, or improper storage.
2. Damage resulting from accident, neglect, or other circumstances beyond Kreg Enterprises, Inc. control.
3. Modifications, disassembly, tampering, alterations, or repairs made outside of Kreg Enterprises, Inc. facilities without Kreg Enterprises, Inc. authorization.
4. Removal of the original serial-number tag.

To obtain warranty service, contact Kreg Enterprises, Inc. at:

Kreg Enterprises, Inc.
7500 SE Convenience Blvd.
Ankeny, IA 50021
800.447.8638
technicalsupport@kregtool.com

DO NOT RETURN THE SAW TO THE DEALER FOR WARRANTY SERVICE.

Proof of purchase is required before remedy will be provided under the terms of this warranty. Kreg Enterprises, Inc. assumes no responsibility for products returned without prior authorization. Kreg Enterprises, Inc. obligations under this warranty shall be limited to repairing or replacing, at Kreg Enterprises, Inc. option, products which are determined, upon delivery to and inspection by Kreg Enterprises, Inc., to be defective. Under no circumstance shall Kreg Enterprises, Inc. be liable for incidental or consequential damages resulting from defective products, nor shall Kreg Enterprises, Inc. liability exceed the price paid for the product by the original purchaser.

This is the Kreg Enterprises, Inc. sole warranty. Any and all other warranties which may be implied by law, including any warranties for merchantability or fitness for a particular purpose, are hereby limited to the duration of this warranty. Kreg Enterprises, Inc. shall not be liable for any loss, damage or expense directly or indirectly related to the use of this product or from any other cause or for consequential damages, including without limitation, loss of time, inconvenience, and loss of production. The warranty contained herein may not be modified and no other warranty, expressed or implied, shall be made by or on behalf of Kreg Enterprises, Inc.

This warranty is in effect only if the product is registered with Kreg Enterprises, Inc. within ten (10) days of date of delivery to the original purchaser.

You can register your product:

Online: <https://www.kregtool.com/customer-service/register-a-product.aspx>

By Calling: 800.447.8638 (M-F 8am-5pm CST)

Keep this form for your records.

The following information will be useful in the event warranty service is required. Keep a copy of your purchase invoice with this form.

Date of Purchase: ____/____/____

Purchased From: _____

Serial Number (located on the motor specification label on the motor housing): _____



EXPLORE. BUILD. SHARE.

We're makers just like you.
That's why we love to see what you're working on.
Share with the community and get inspired!

#madewithKreg

Get free plans, project resources, and more.
kregtool.com